

NSTX Joint Conference Call

Peter H. Titus, Thursday February 26 2009

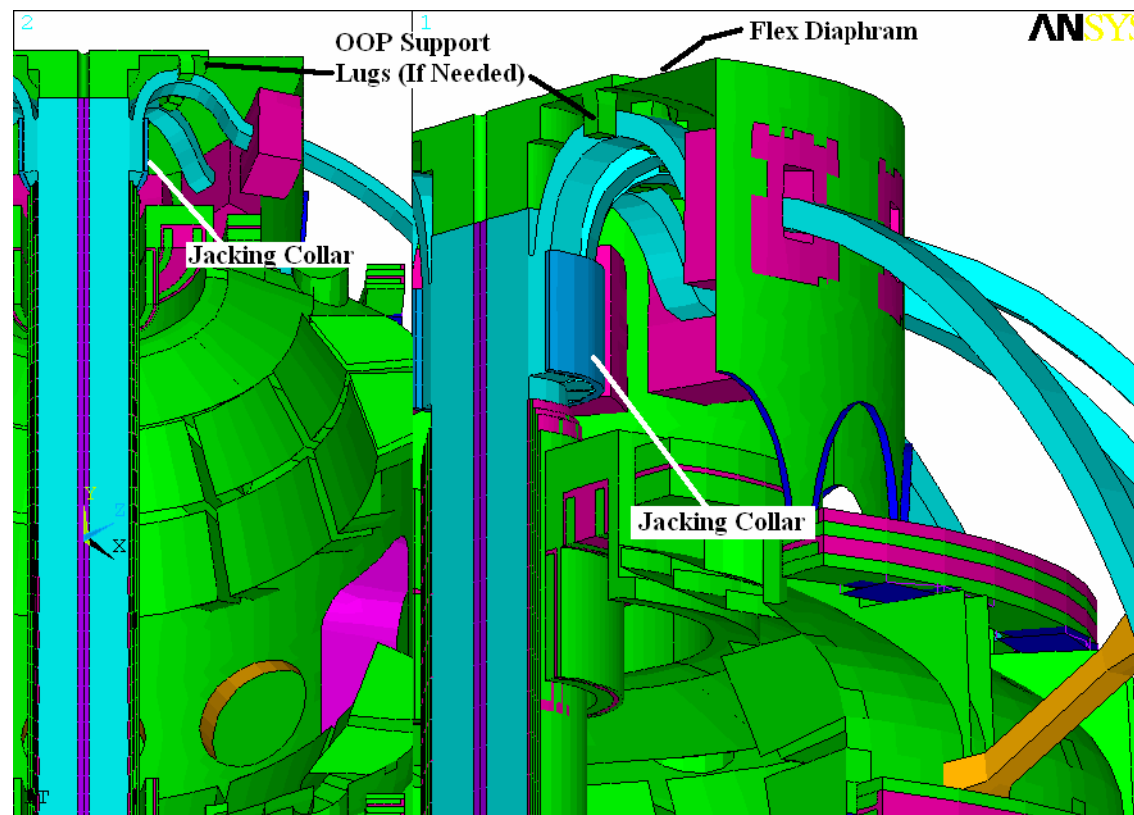

**First Phil's Joint:
Coupled Electromagnetic-Thermal Analysis Then a Stress Pass with an LDREAD of
Lorentz Forces and Temperatures**

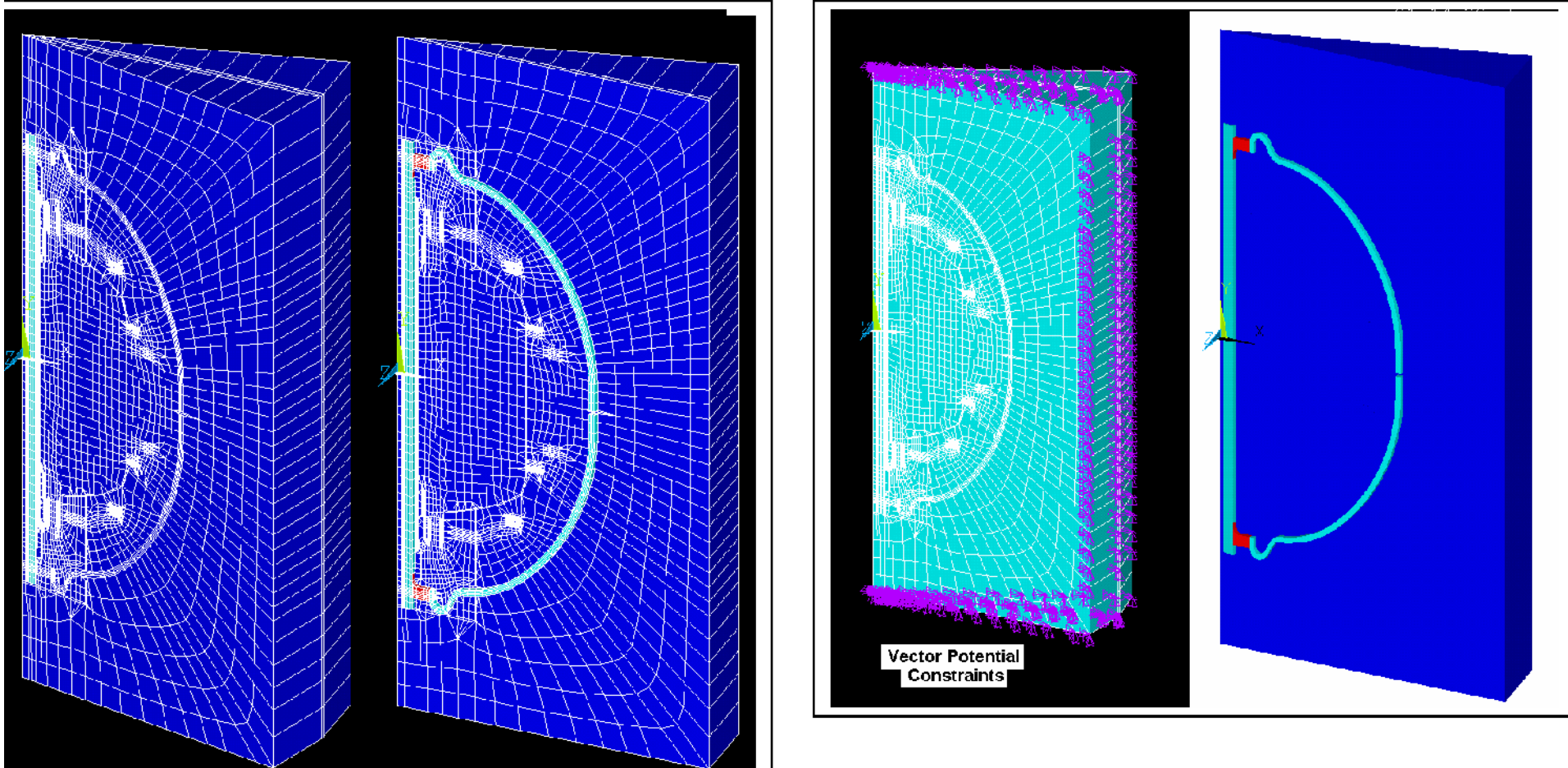

B Field and Current Density Results

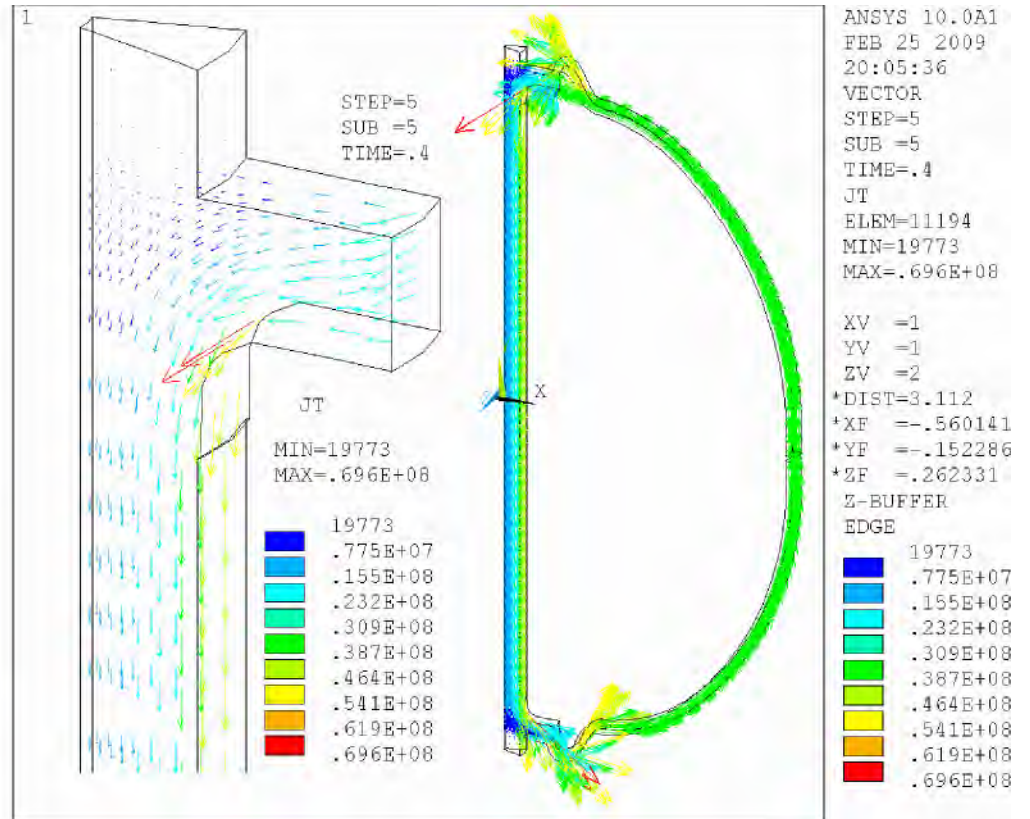
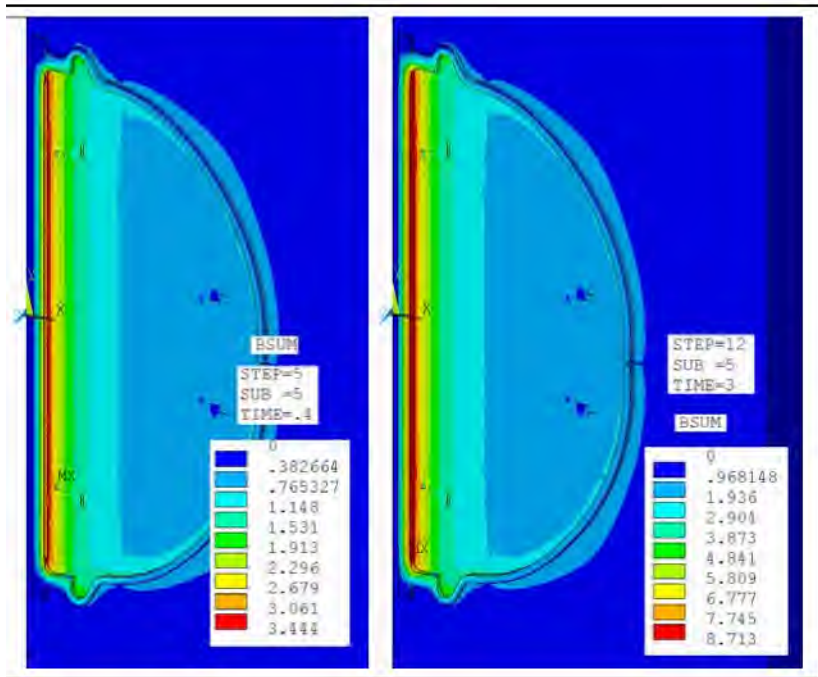

1

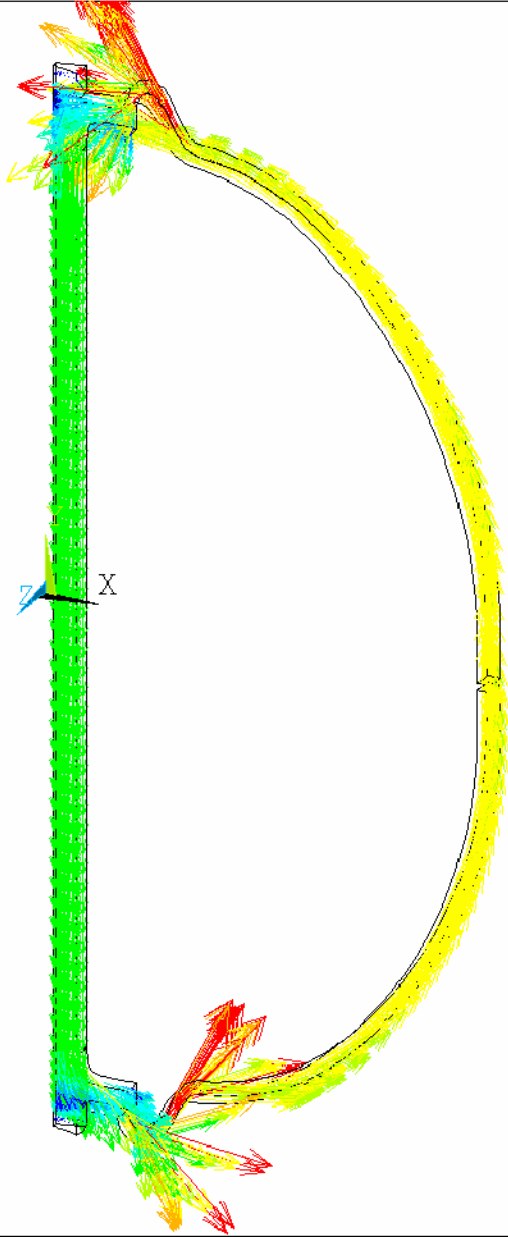
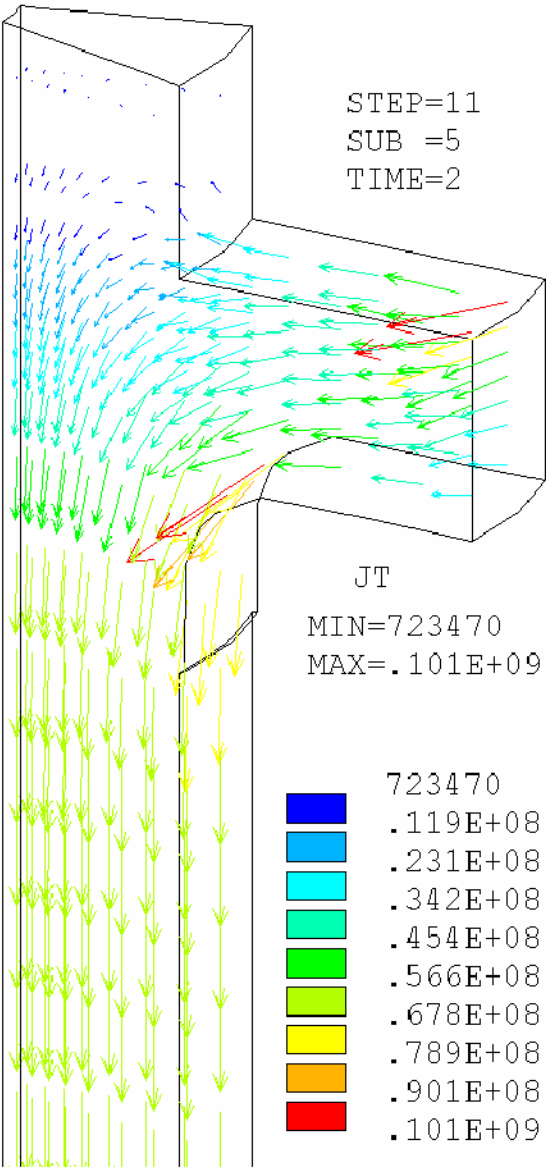

ANSYS 10.0A1
FEB 25 2009
20:06:17
VECTOR
STEP=11
SUB =5
TIME=2
JT
ELEM=7817
MIN=723470
MAX=.133E+09

XV =1
YV =1
ZV =2
*DIST=3.112
*XF =-.560141
*YF =-.152286
*ZF =.262331
Z-BUFFER
EDGE

723470
.154E+08
.301E+08
.449E+08
.596E+08
.743E+08
.890E+08
.104E+09
.118E+09
.133E+09

This text block contains simulation parameters and a legend for the U-bend flow field. It includes the ANSYS version and date, step and time information, element ID, and a color-coded legend for velocity magnitude.

Thermal Results

FEB 25 2009
19:24:46

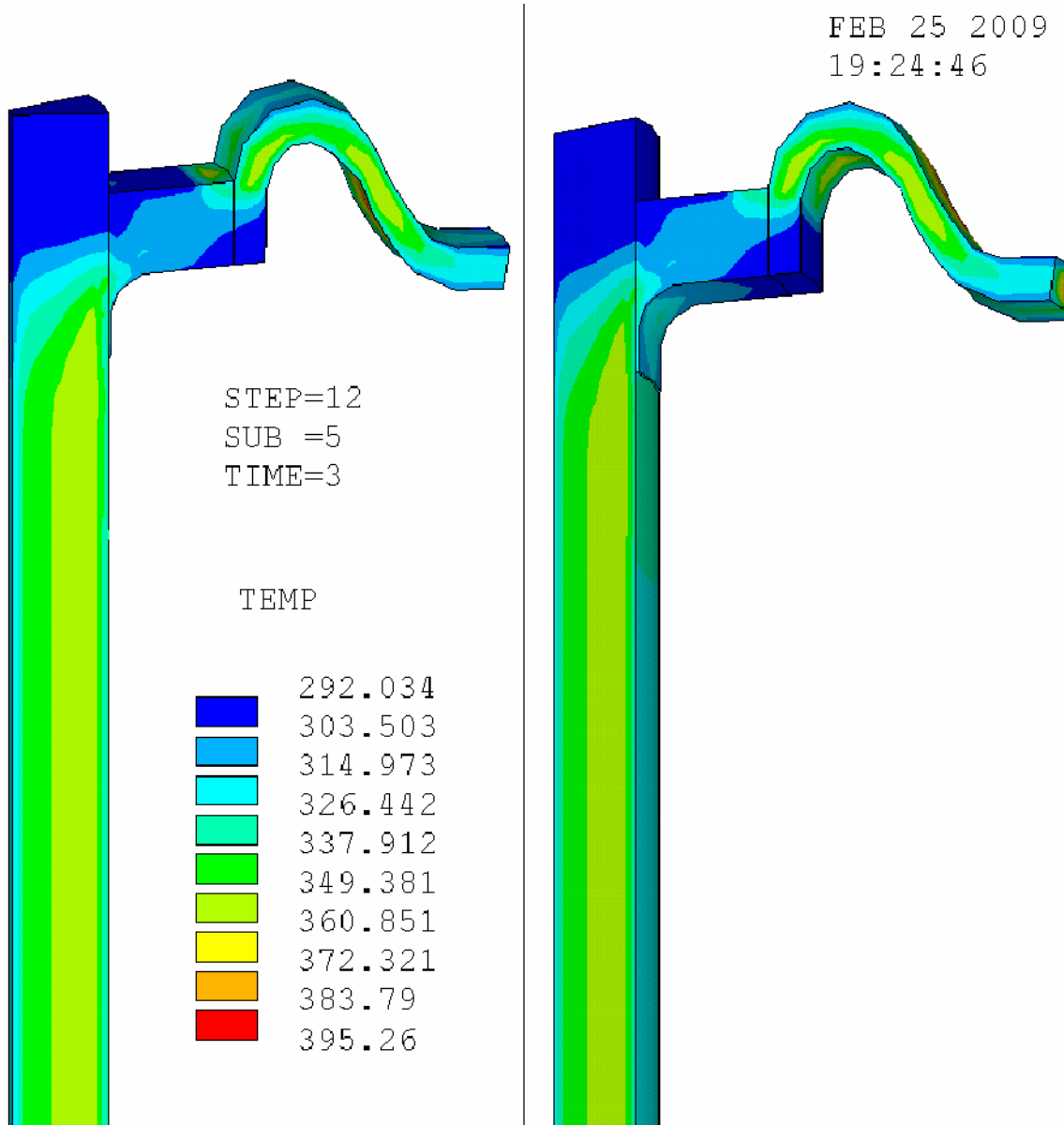

Average Inner Leg Temp is Supposed to be 100C or 373 K

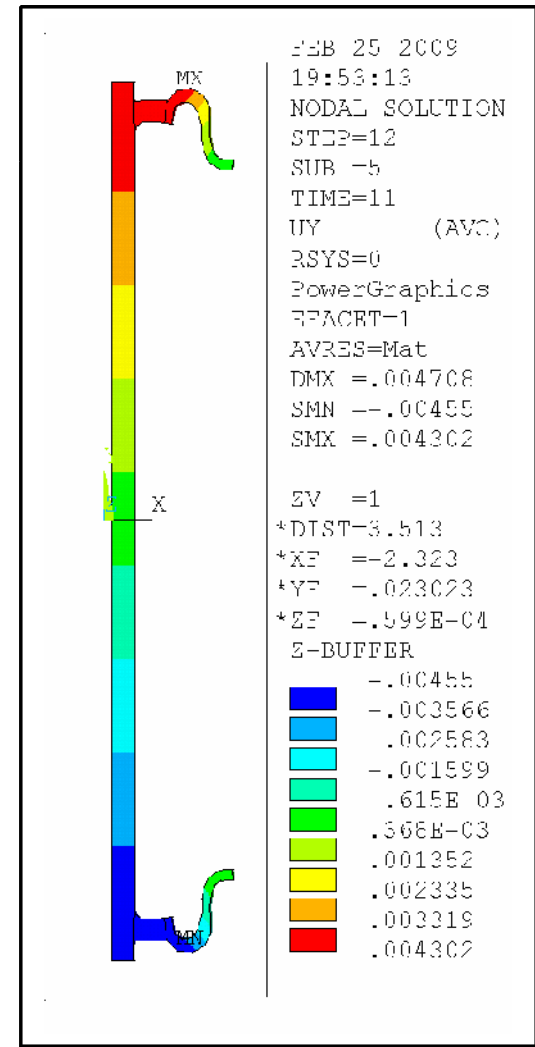
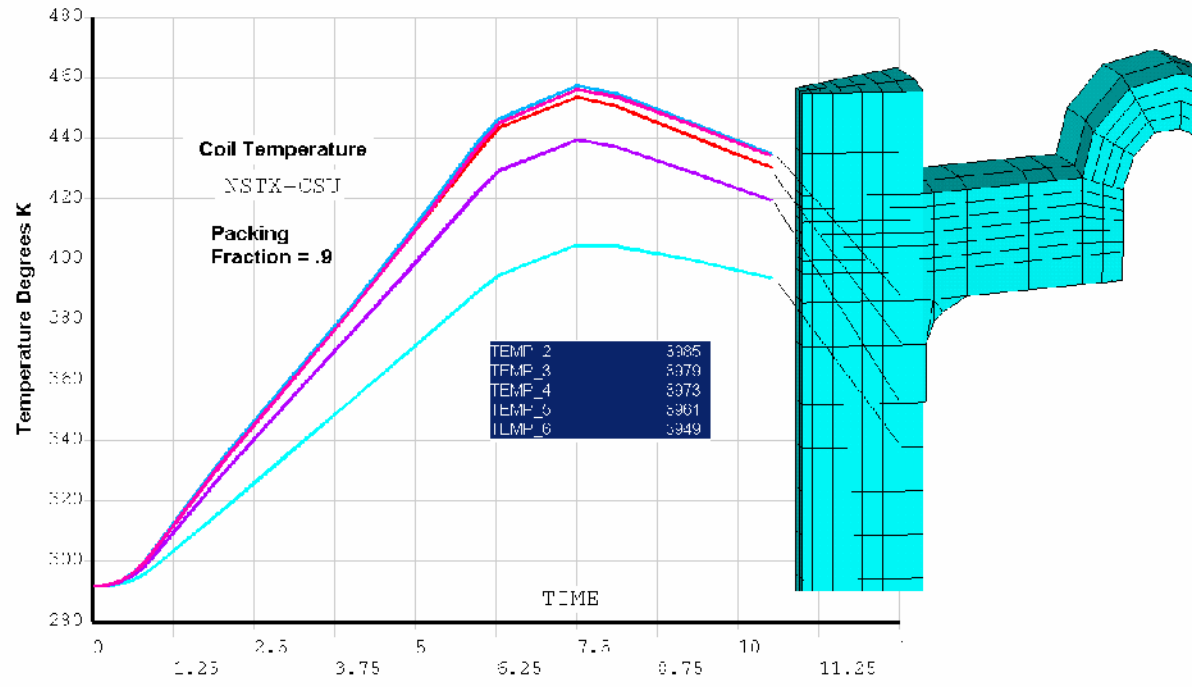

Structural Pass

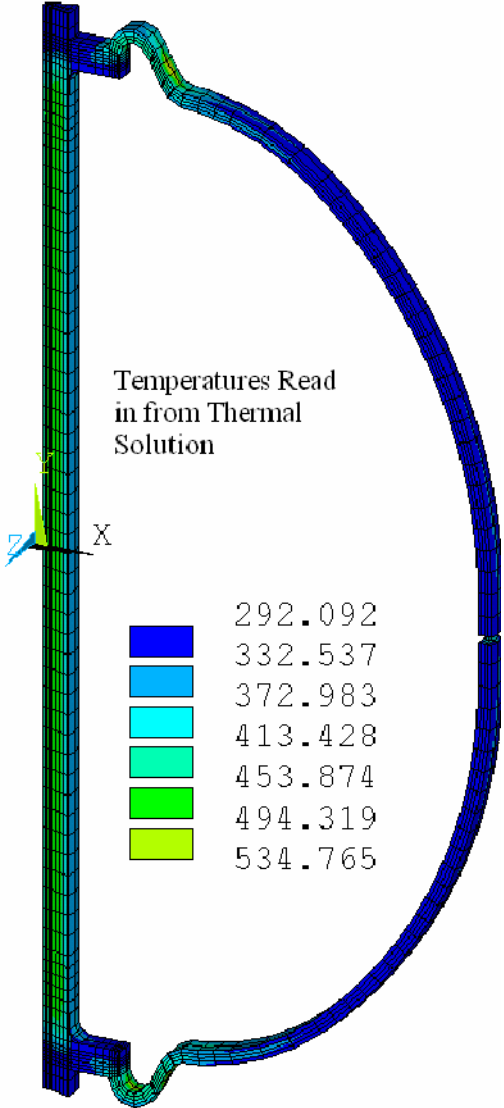
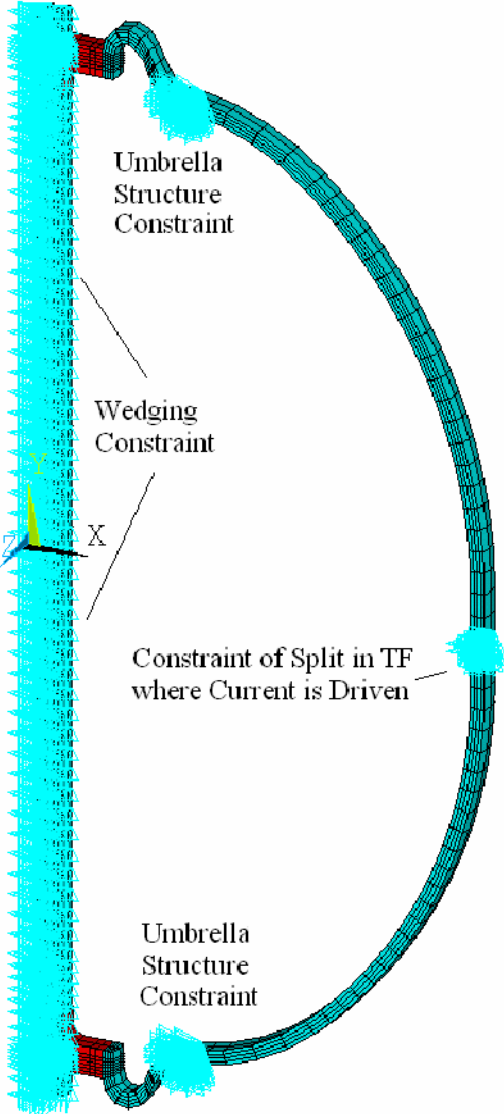
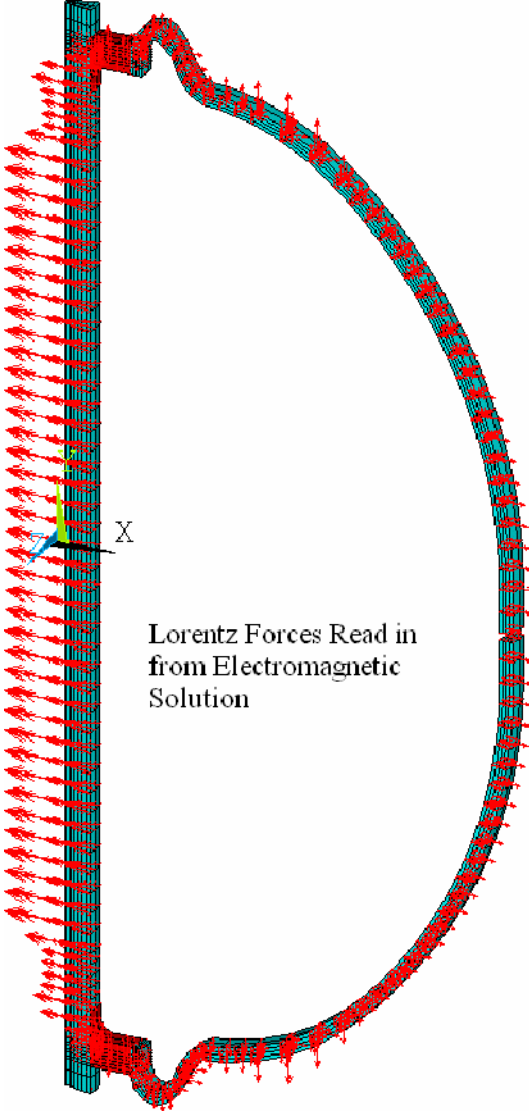

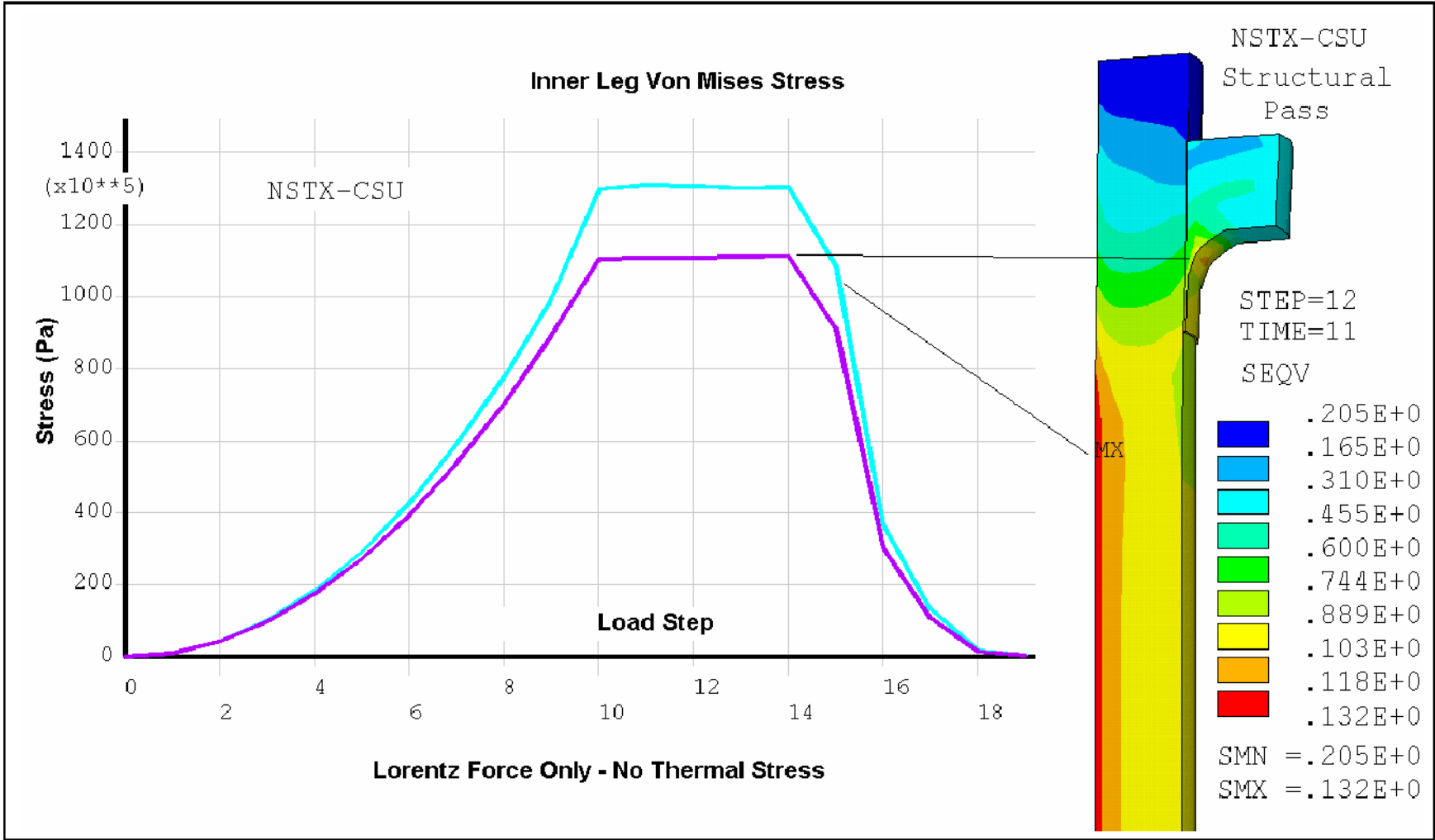

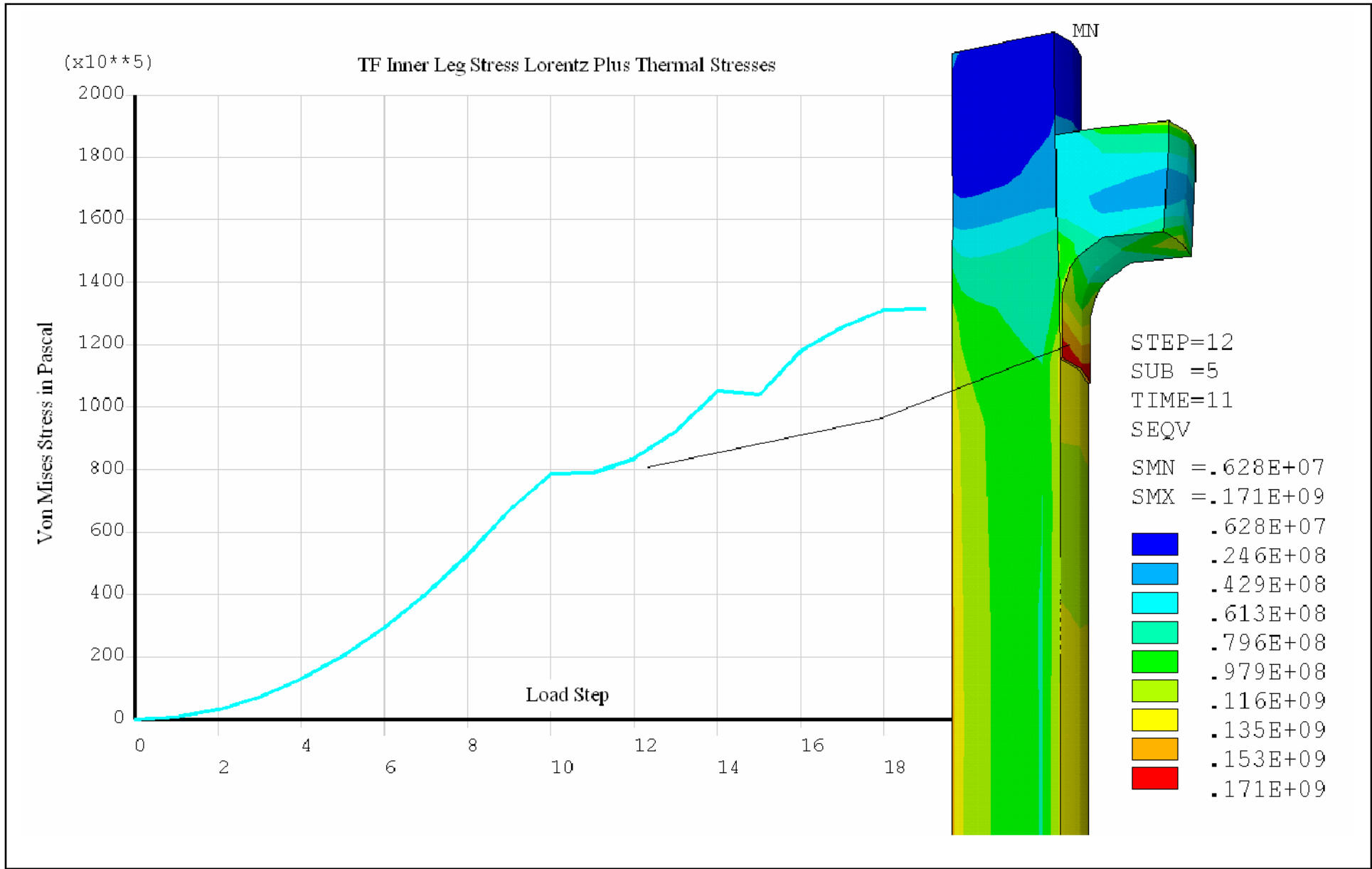

Next, the Titus-Woolley-? Joint

- Jacking Ring
- Big Constant Tension (Sort-of) Expansion Loop

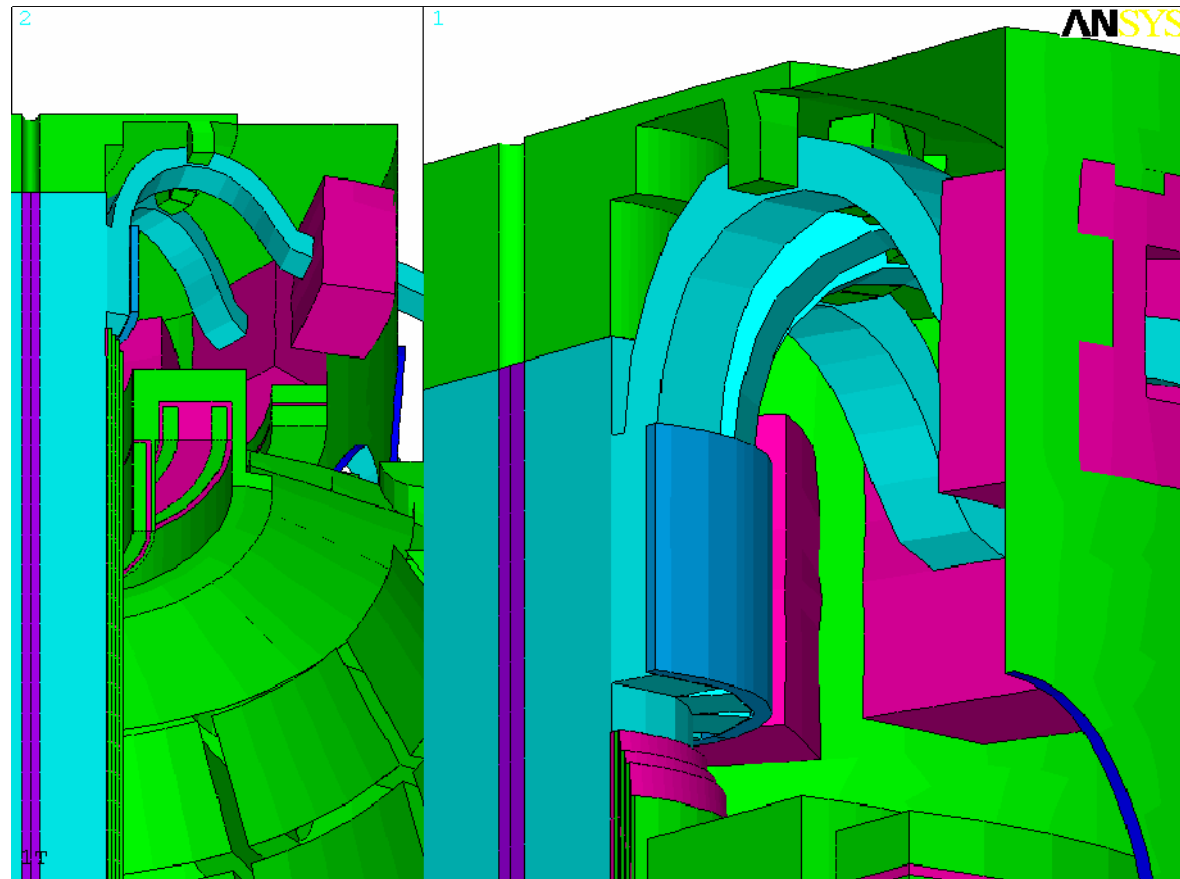

Titus-Woolley-? Joint Electromagnetic-Thermal Analysis

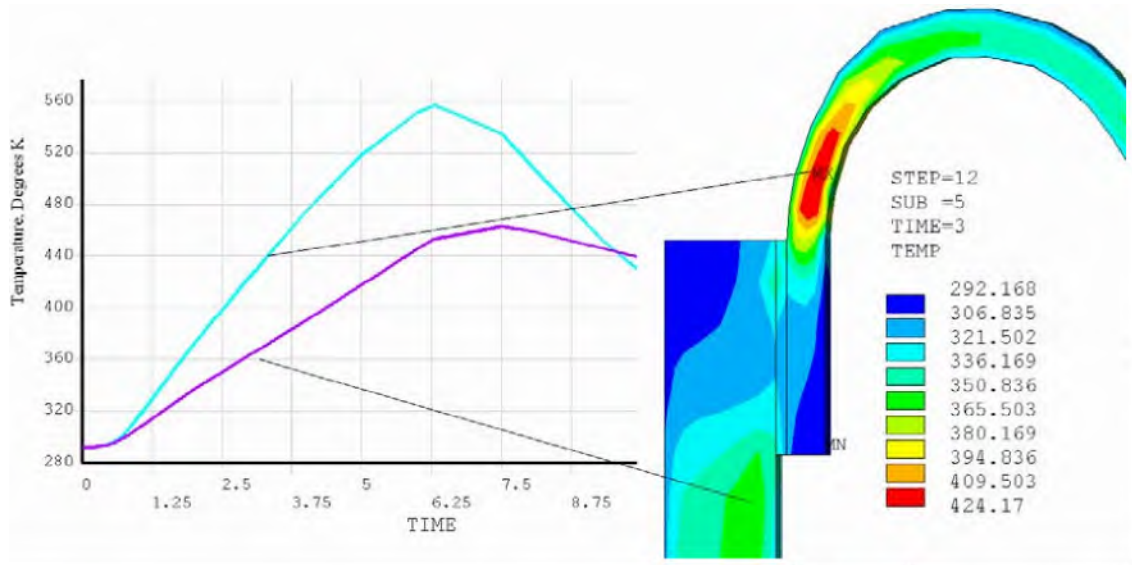

Much of the stress in the loop appears to be a result of the thermal gradient.

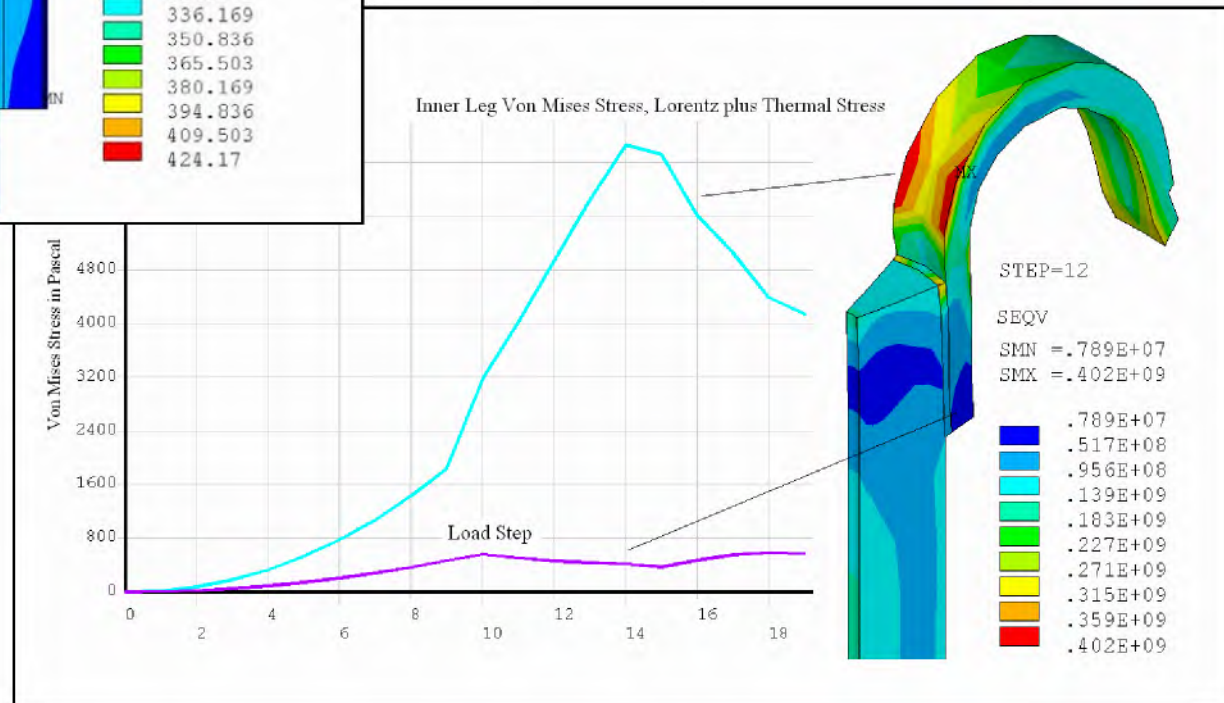

Global Structural Modeling of the Titus-Woolley-? Joint

- This time the inner leg is at 100C temp and the outer leg is at 50C
- Integrated central column expansion is close to the electromagnetic thermal diffusion model

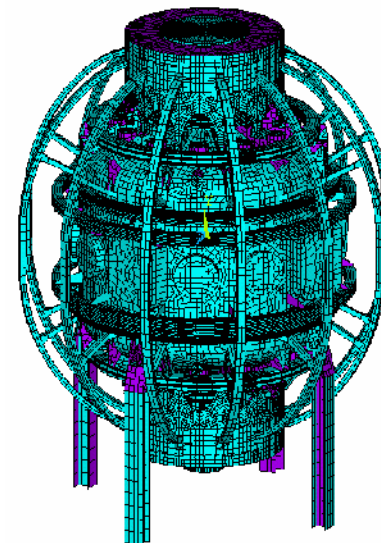

Four Fold Symmetry Expansion. HM Provided the Vessel Model

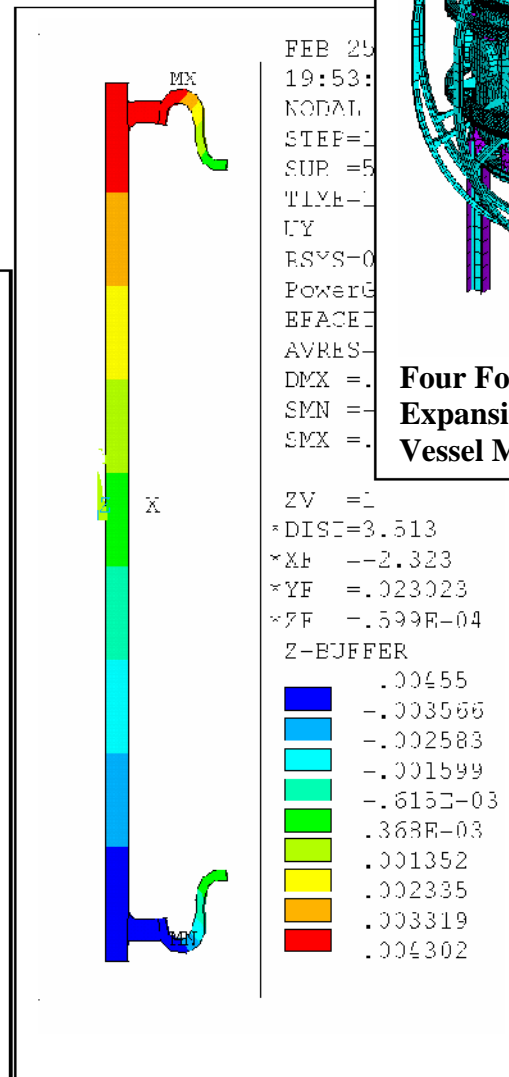
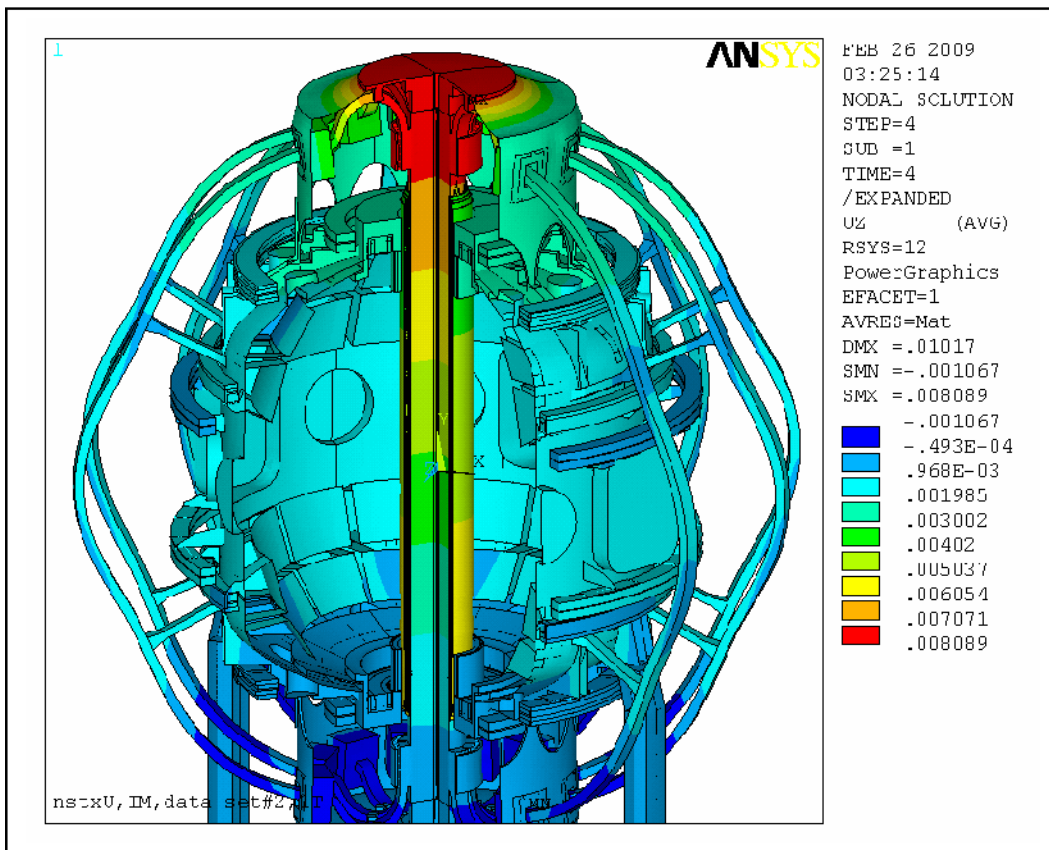

Radial Compression from the Jacking Ring

In this run I used 1 mm interference. Ring stress and compression are too large
I have run .5mm but have not post-processed it.

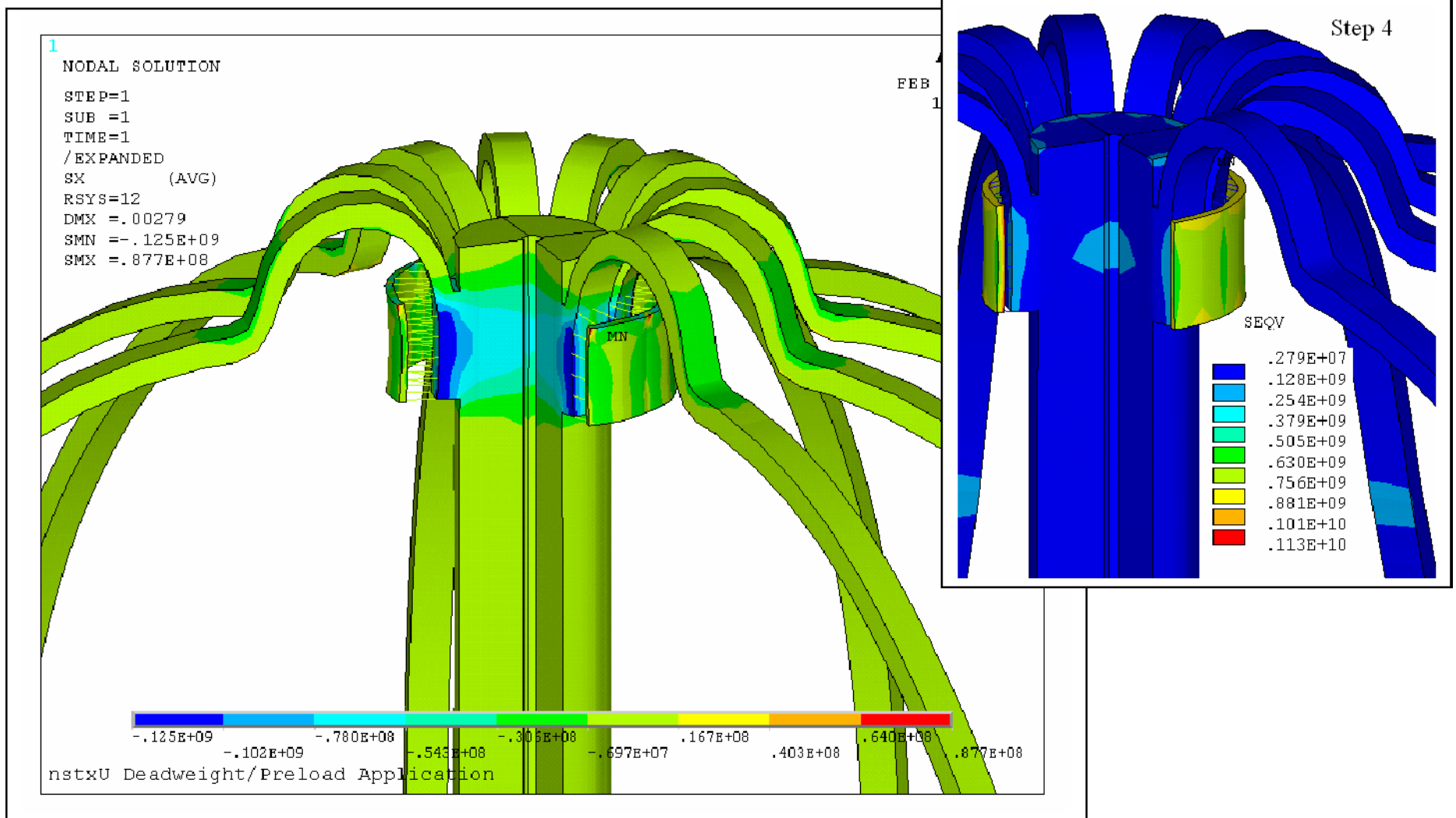

D-Wedging Effect is Minimal

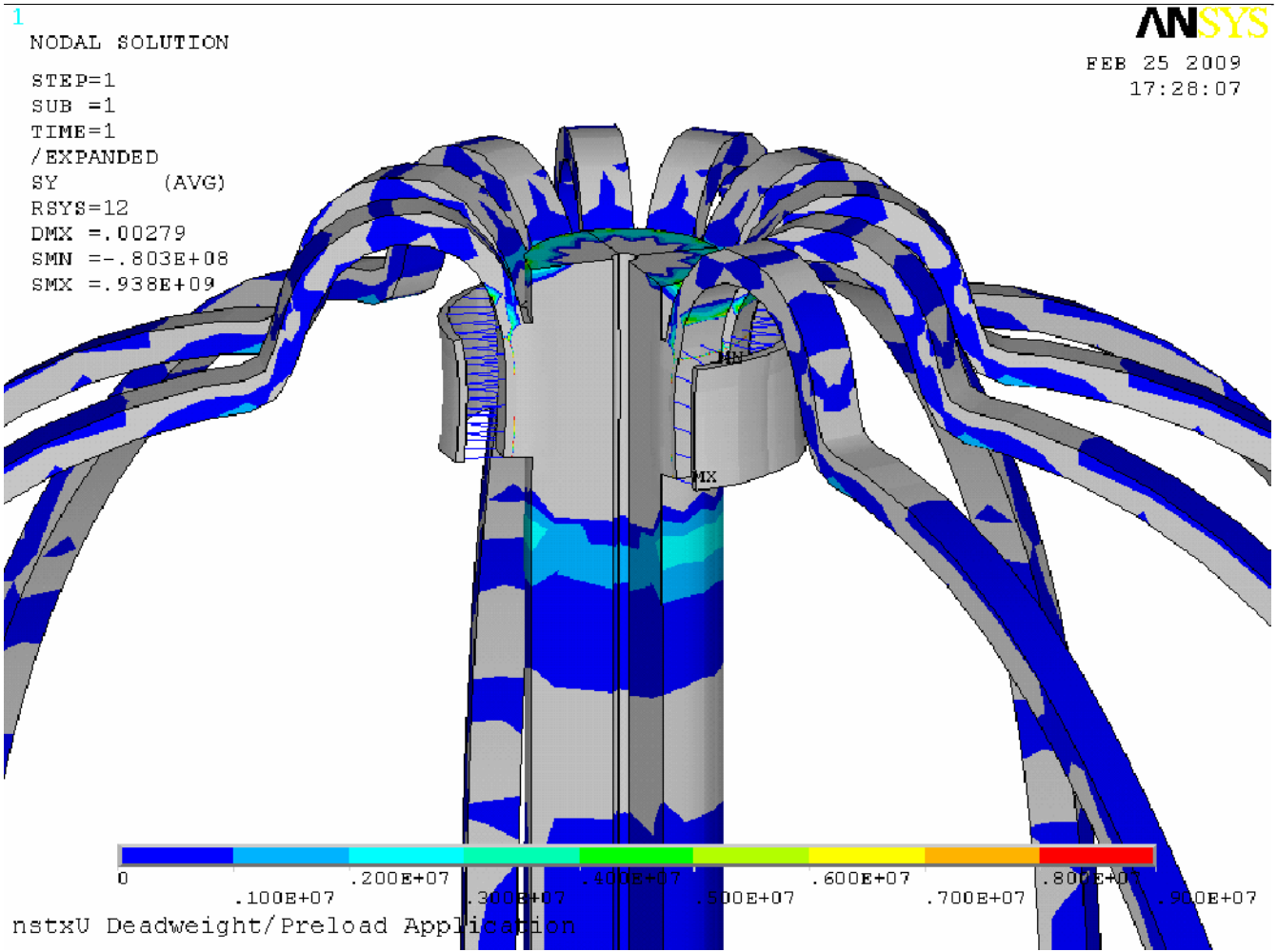

NODAL SOLUTION

STEP=2

SUB =1

TIME=2

/EXPANDED

SEQV (AVG)

DMX =.007304

SMN =954465

SMX =.231E+09

ANSYS

FEB 25 2009

17:47:52

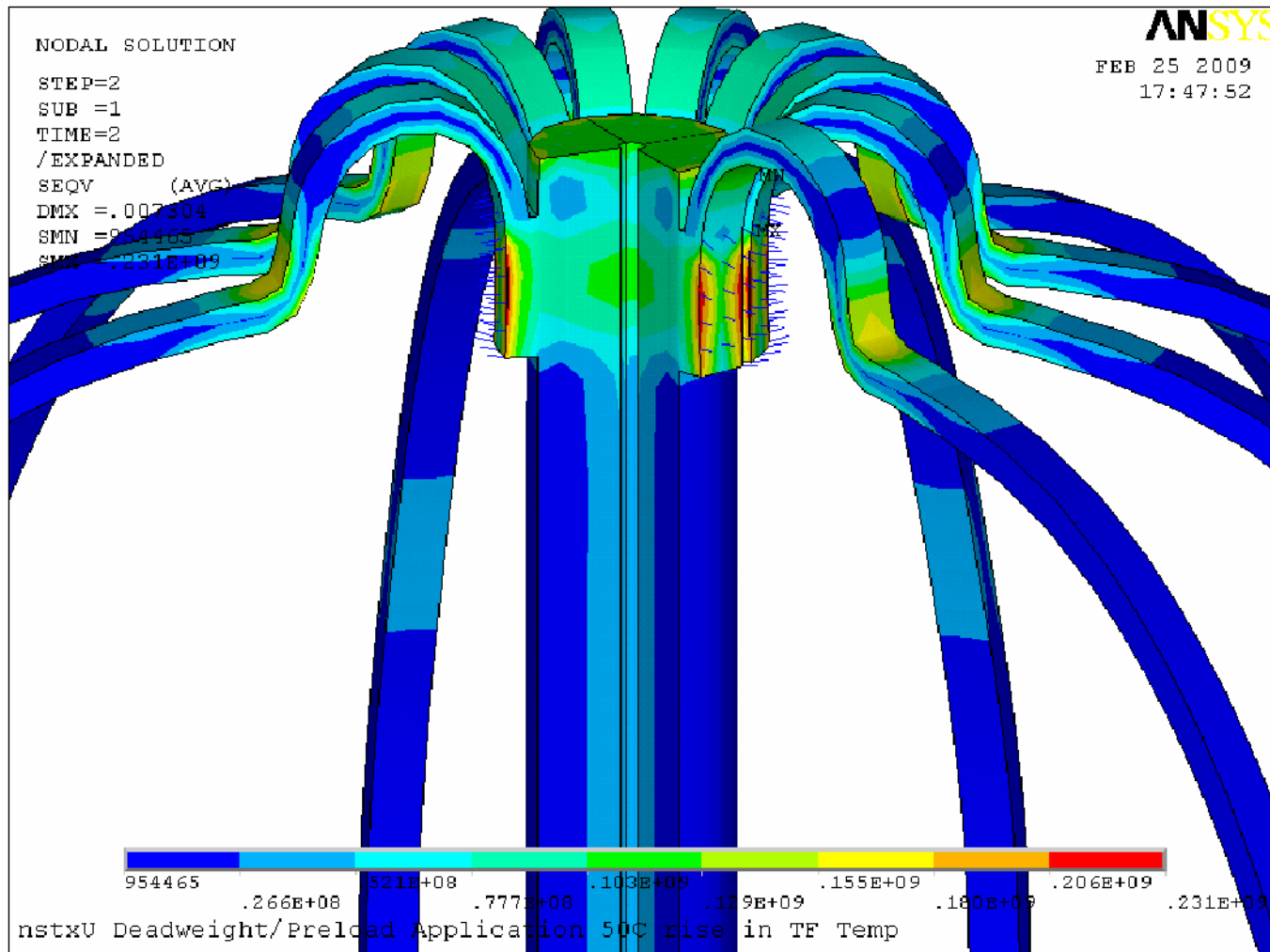

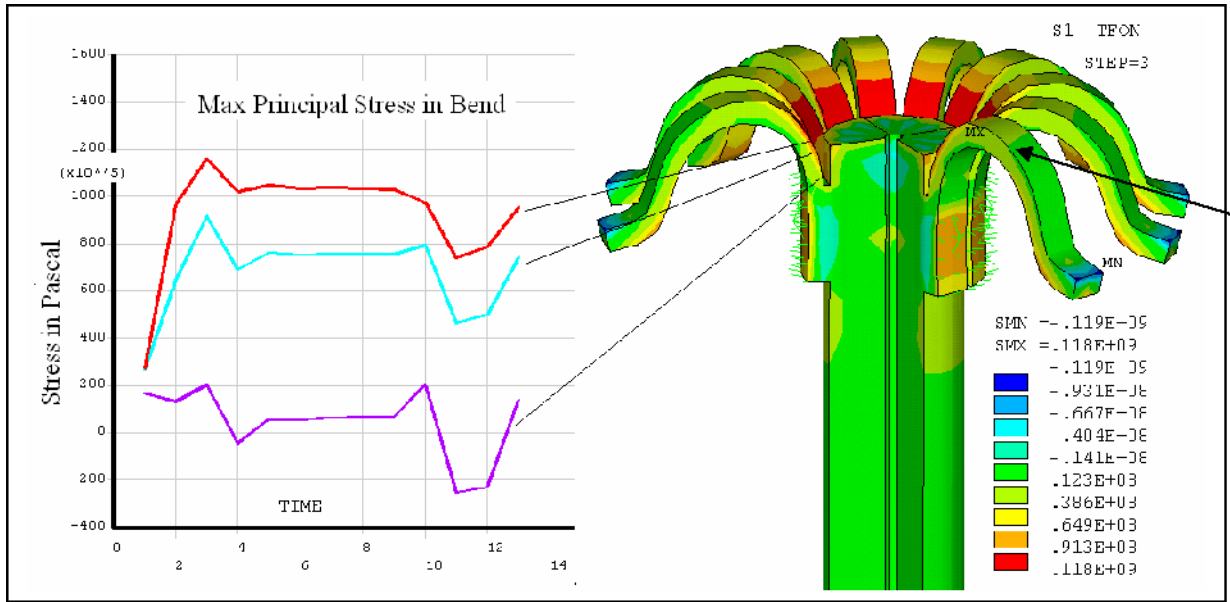

Max Principal Stress In Bend. –No Internal Thermal Gradient
Max is 118 MPa
Max is 166 MPa

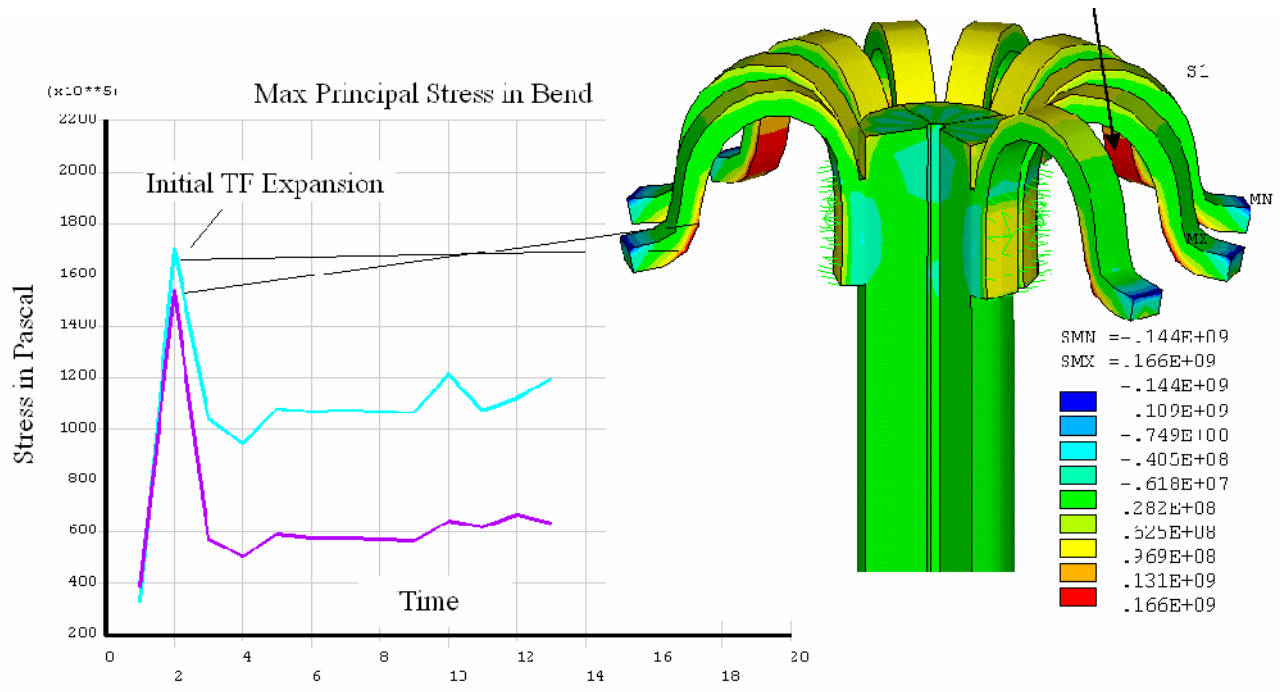

Jacking Ring Compression Helps Support Torsion

Ring height might be increased to improve torsional carrying capacity of the extension that connects with the umbrella structure hub

Wedge Pressure

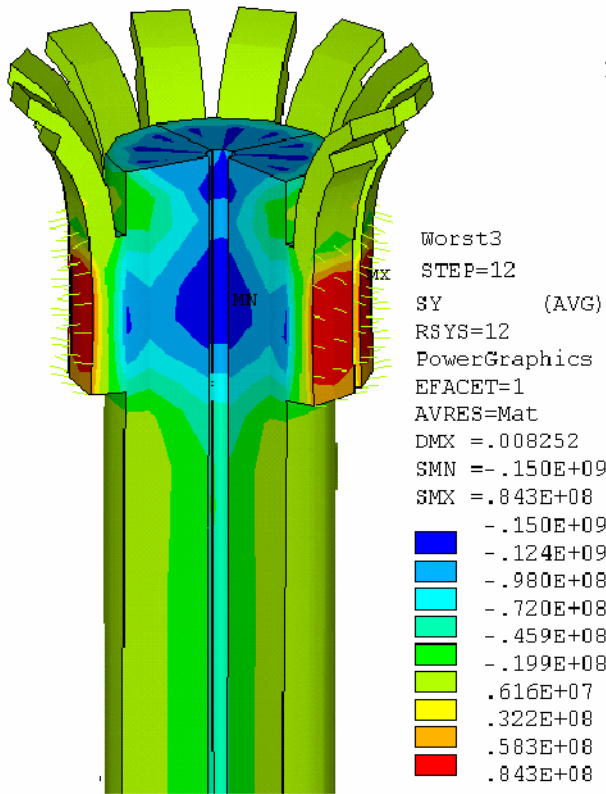

Radial Pressure Imm Interference

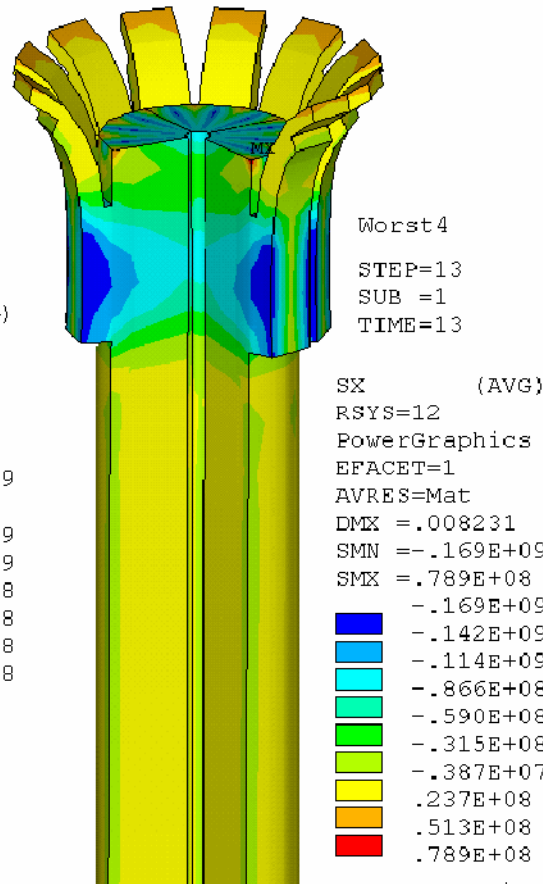

Torsional Shear Stress

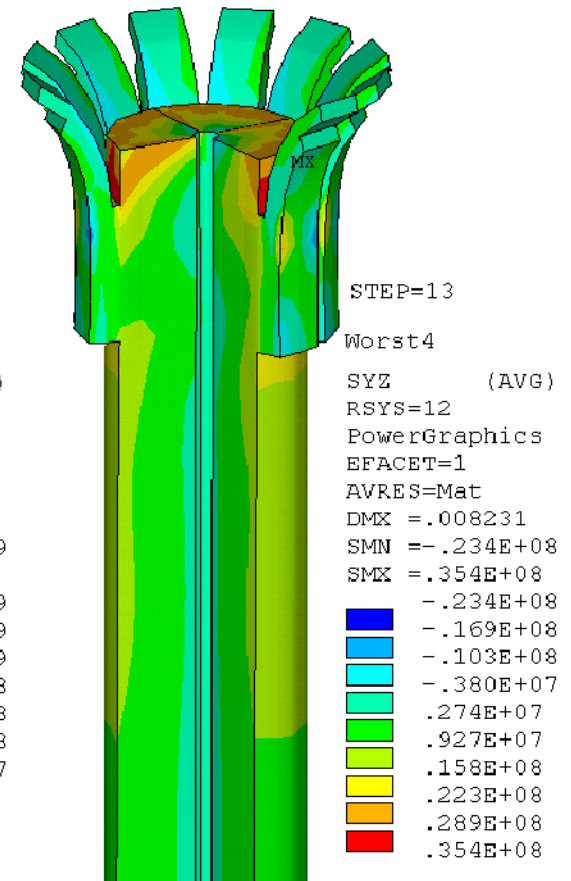

More “Worst” Torsional Shear Stresses

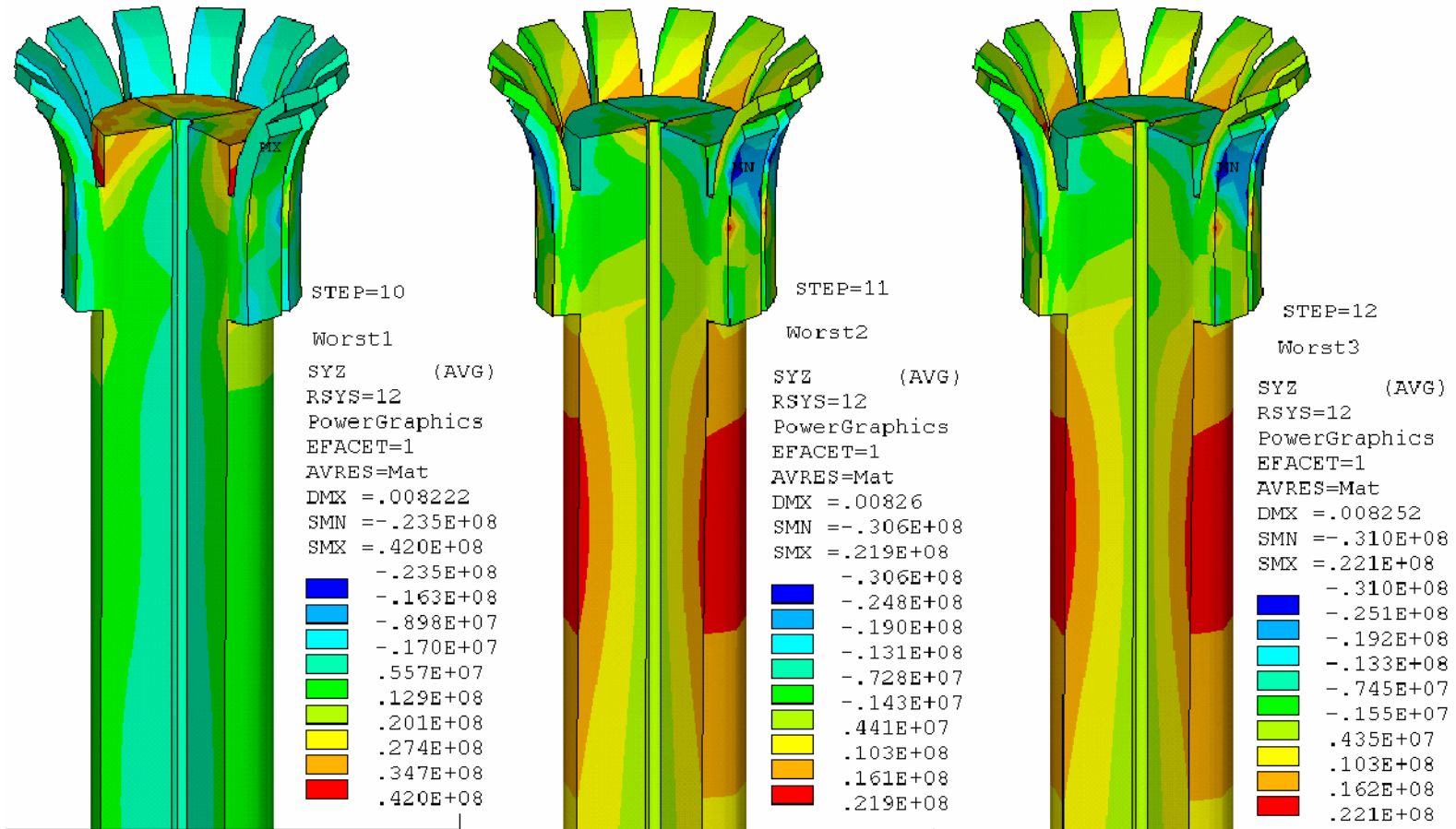

Conclusions:

Titus-Woolley-? Joint :

- **Can Develop Needed Contact Pressures**
- **Expansion Loop Can Absorb Central Column Vertical Motion With Acceptable Stress**
- **Jacking Ring Compression Aids Torsional Shear Carrying Capacity**
- **No Mechanical Connections Penetrating the TF Inner Leg**
- **Jacking Ring Compression Supports in-Plane Shear Carrying Capacity**
- **OOP Support Lugs D Not Appear to be Needed**