

Coil Support Structures

Design by D. Mangra
Presented by L. Dudek

NSTX Upgrade Project
Conceptual Design Review
LSB, B318
October 28-29, 2009

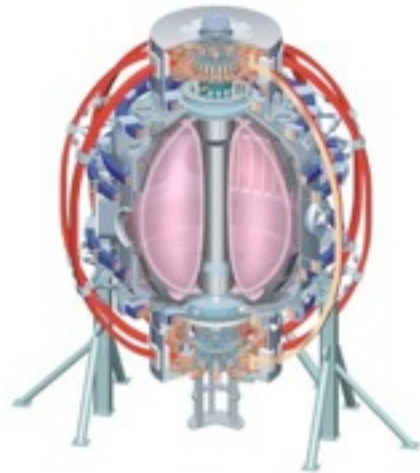

College W&M
 Colorado Sch Mines
 Columbia U
 CompX
 General Atomics
 INEL
 Johns Hopkins U
 LANL
 LLNL
 Lodestar
 MIT
 Nova Photonics
 New York U
 Old Dominion U
 ORNL
 PPPL
 PSI
 Princeton U
 Purdue U
 SNL
 Think Tank, Inc.
 UC Davis
 UC Irvine
 UCLA
 UCSD
 U Colorado
 U Illinois
 U Maryland
 U Rochester
 U Washington
 U Wisconsin

Culham Sci Ctr
 U St. Andrews
 York U
 Chubu U
 Fukui U
 Hiroshima U
 Hyogo U
 Kyoto U
 Kyushu U
 Kyushu Tokai U
 NIFS
 Niigata U
 U Tokyo
 JAEA
 Hebrew U
 Ioffe Inst
 RRC Kurchatov Inst
 TRINITI
 KBSI
 KAIST
 POSTECH
 ASIPP
 ENEA, Frascati
 CEA, Cadarache
 IPP, Jülich
 IPP, Garching
 ASCR, Czech Rep
 U Quebec

Outline

- Tasks
- Scope / Requirements / Standards
- Existing Structure
- Design Approach
- Issues
- Summary

Structural- Design

- Scope:
 - Structural Support Components
 - Support Coils: TF, PF2, PF3, PF4 and PF5
 - Support Pedestal: To Support new Center Stack
 - Umbrella structure reinforcement to carry higher magnetic loads
- Requirements:
 - Resist Forcing Inputs
 - Interface with Legacy equipment
 - Real Estate available for installation
 - Coil Alignment - ~5 mm
- Standards:
 - Stress - in house design standard
 - Installation and handling – Module Size and weight such that parts can be easily handled and installed
 - Minimize the impact to existing hardware
 - Minimize the impact to existing assembly as installed

Force Inputs

Cage Links	Power Supply Limit		Operational Limit	
	Max (lbs)	Min (lbs)	Max (lbs)	Min (lbs)
PF 3 Upr to PF 4 Upr Link	272,631	-314,951	103,217	-150,417
PF 5 Upr to PF 5 Lwr Link	665,724	-666,010	258,062	-239,821
PF 4 Lwr to PF 3 Lwr Link	116,805	-471,392	35,711	-150,441
Upper dome load	194,759	-369,644	59,209	-59,365
Lower dome load	191,694	-194,844	44,531	-59,250
Load by vessel to 4 legs to ground	495,107	-495,329	58,722	-65,529

Existing TF & PF Support Details and integration

*Existing Umbrella Structure
Legs with sliders*

Existing TF ring

Existing ribs

Existing pads

Existing clevis

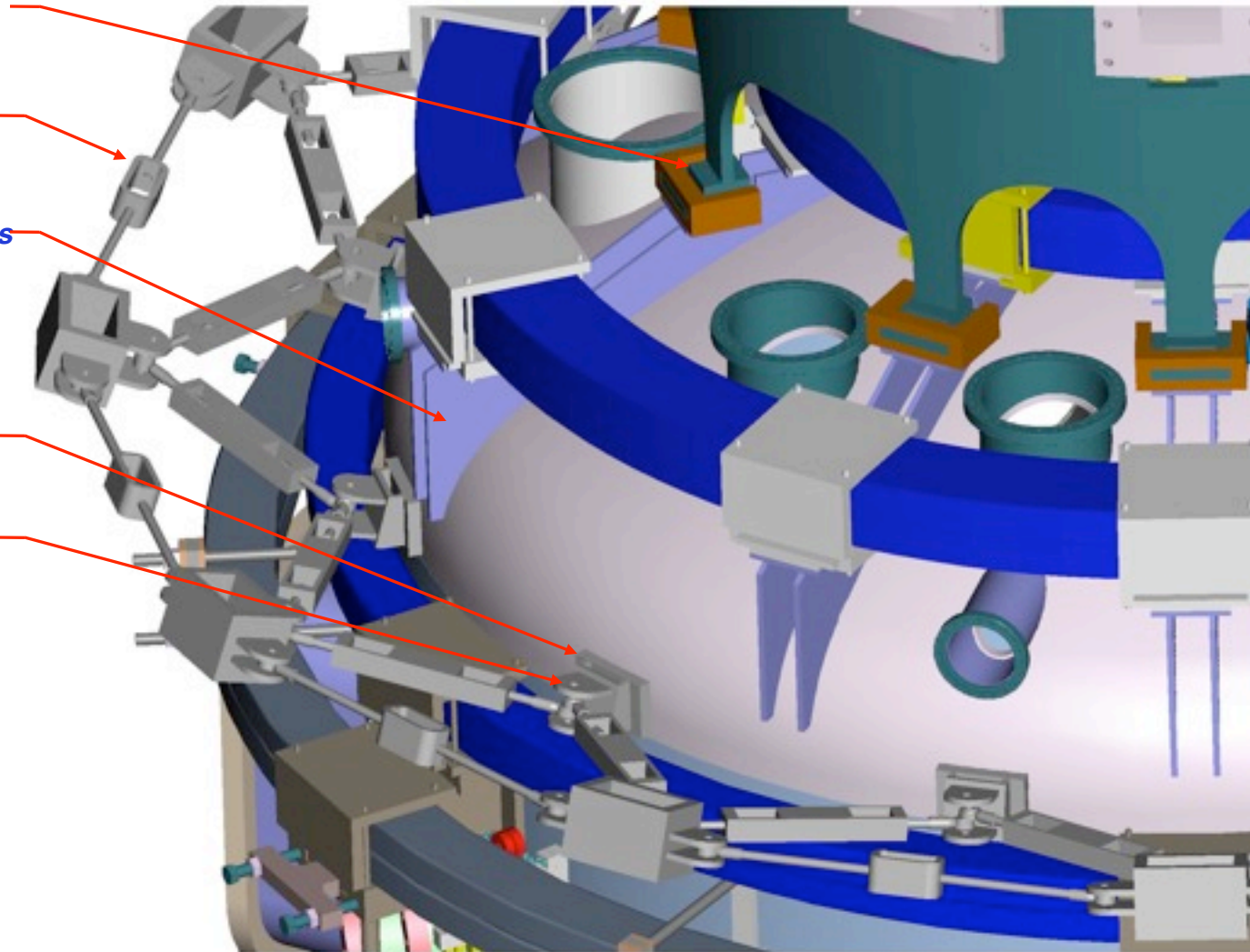

New Supports Designed to use same Real Estate as Existing

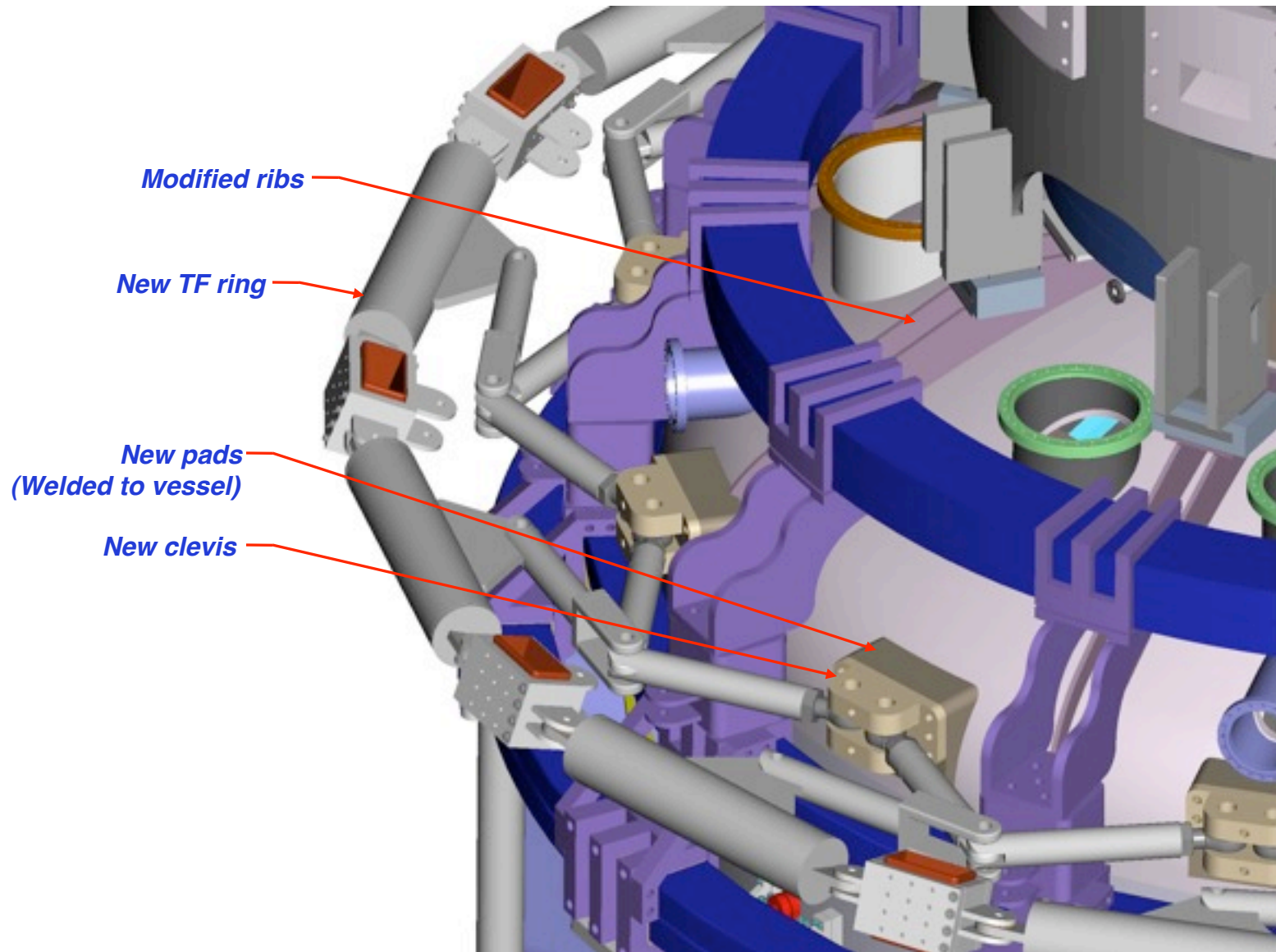

NSTX Main Assembly with PF Cage Support

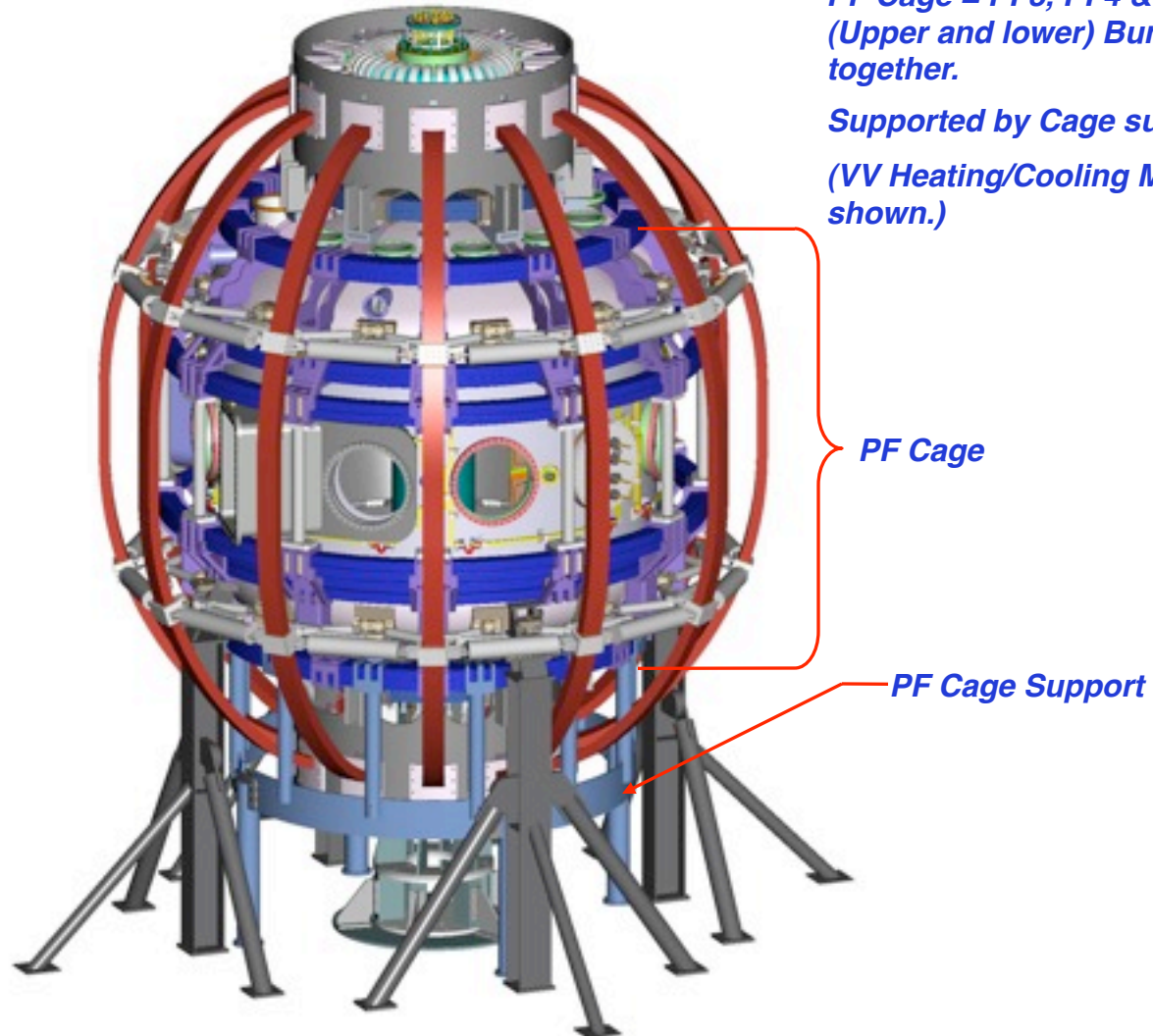

TF Coils and Supports upgrade

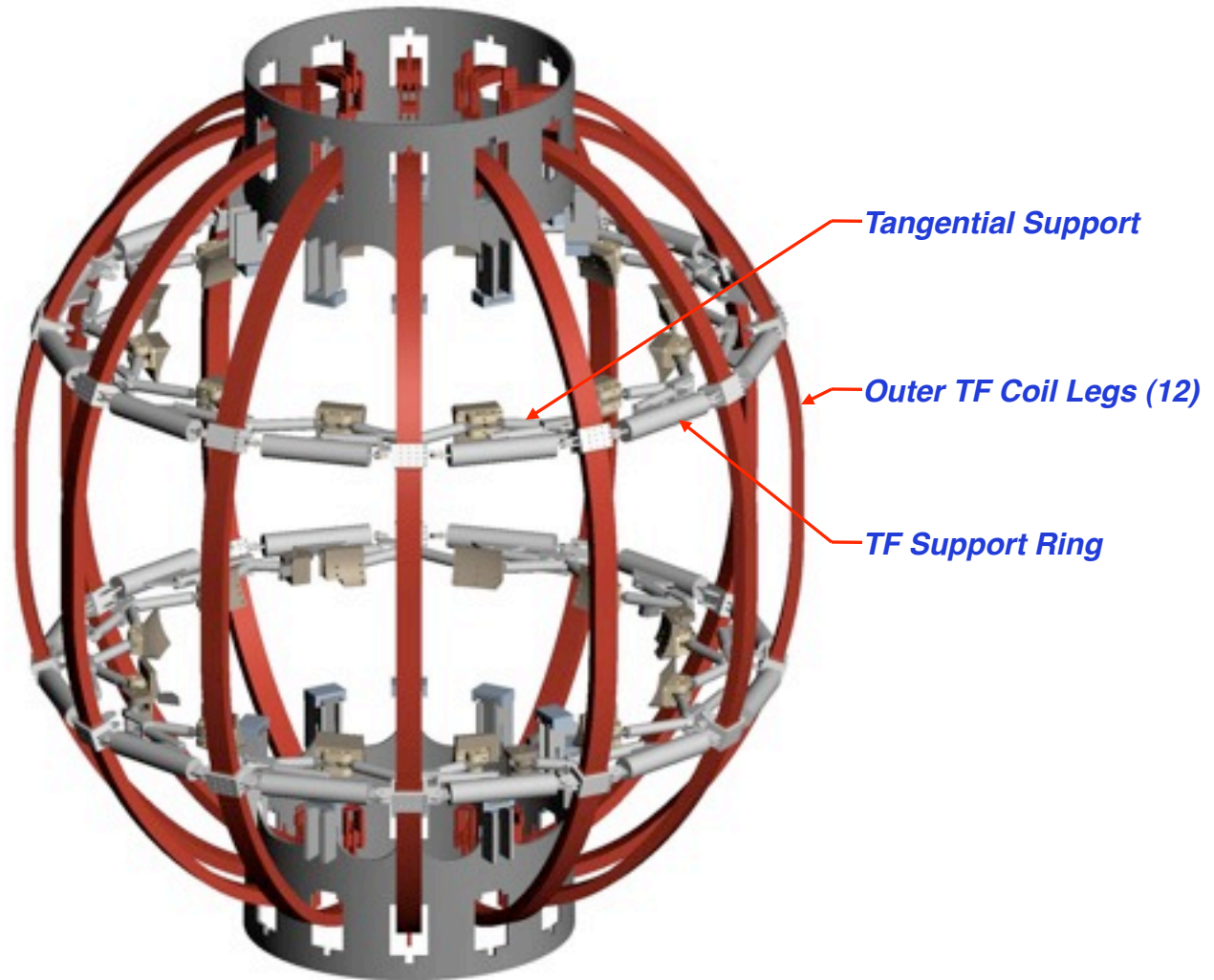

TF Tangential Support Details

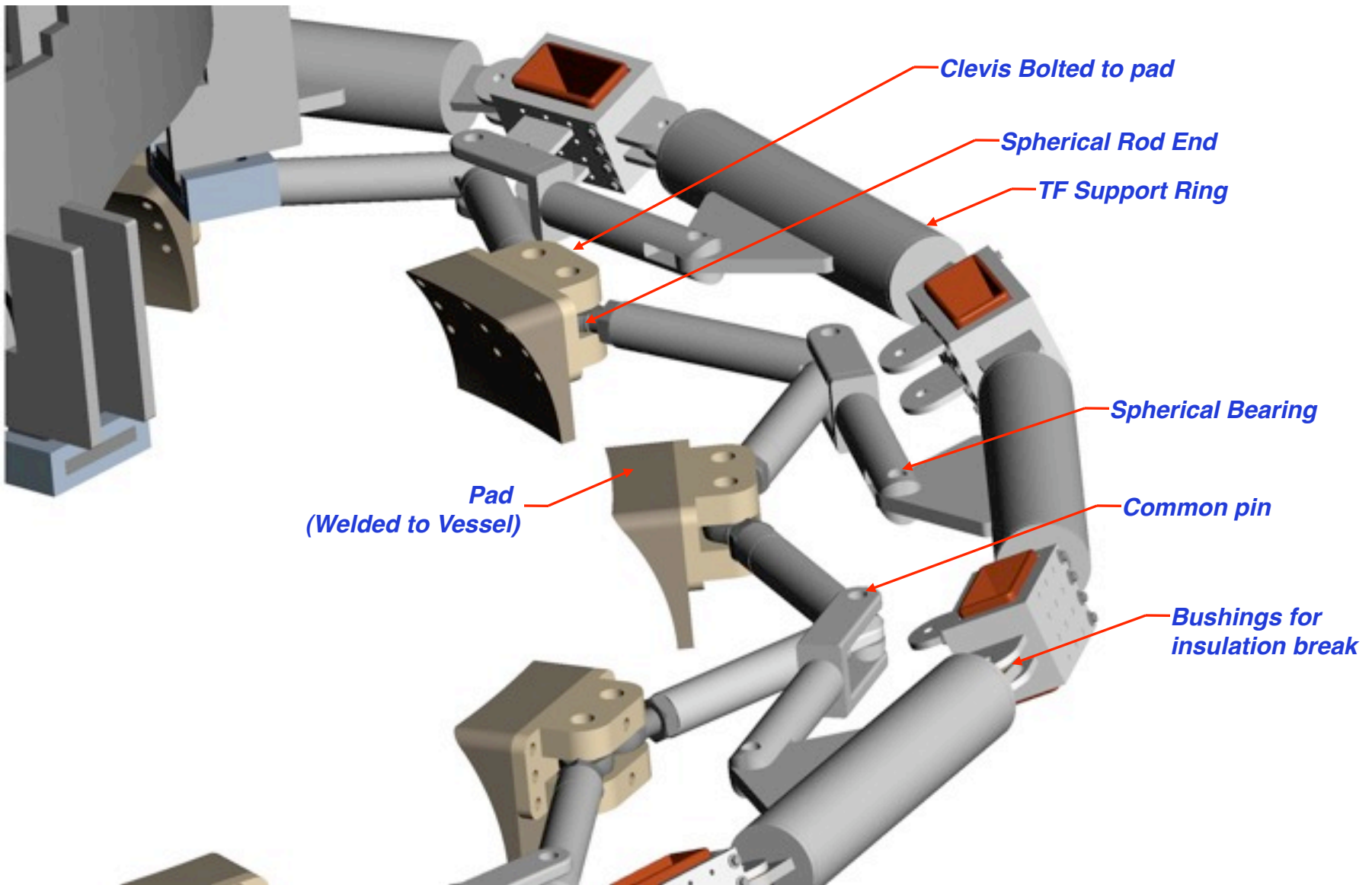

Umbrella Reinforcement

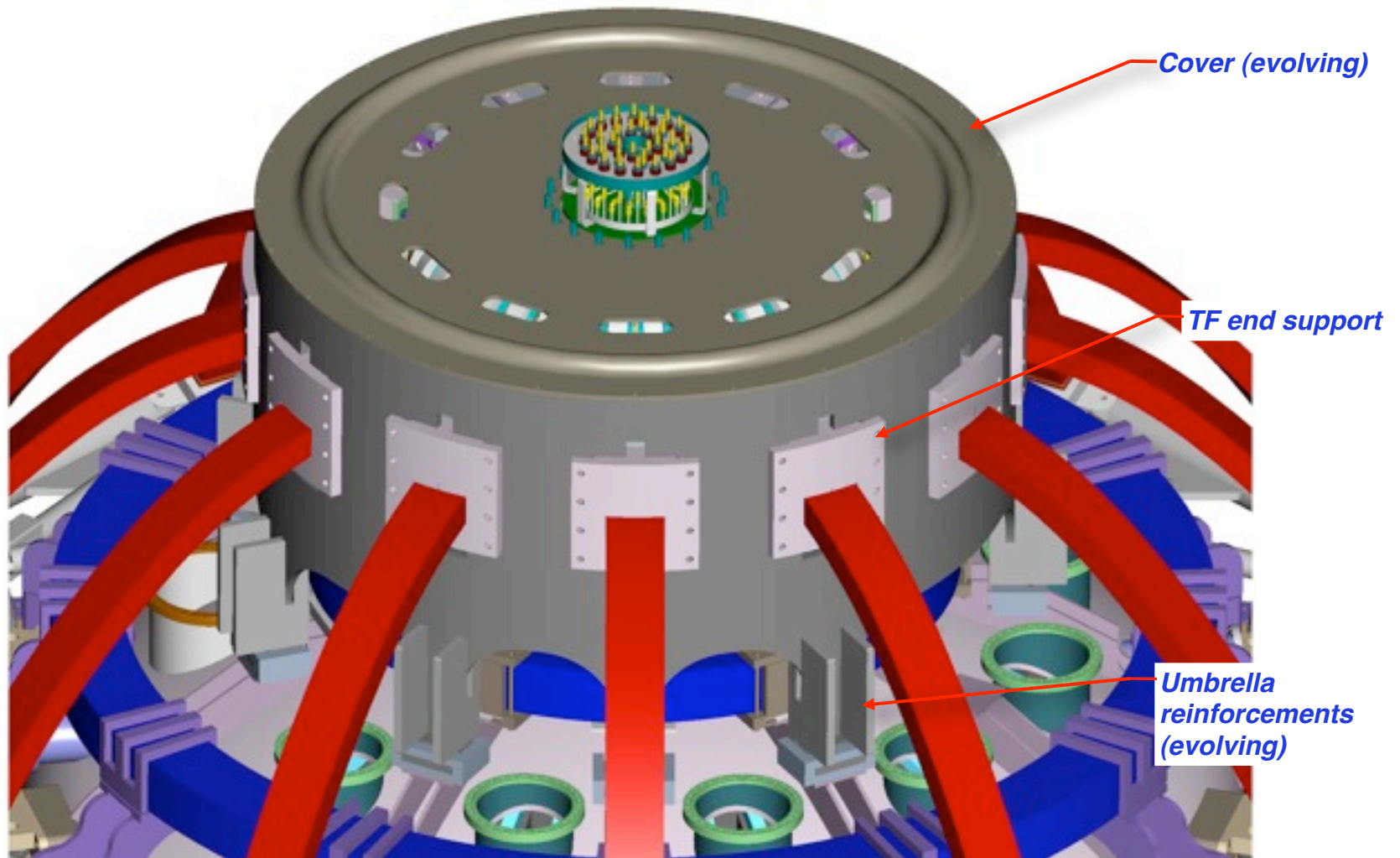

Pedestal Assembly

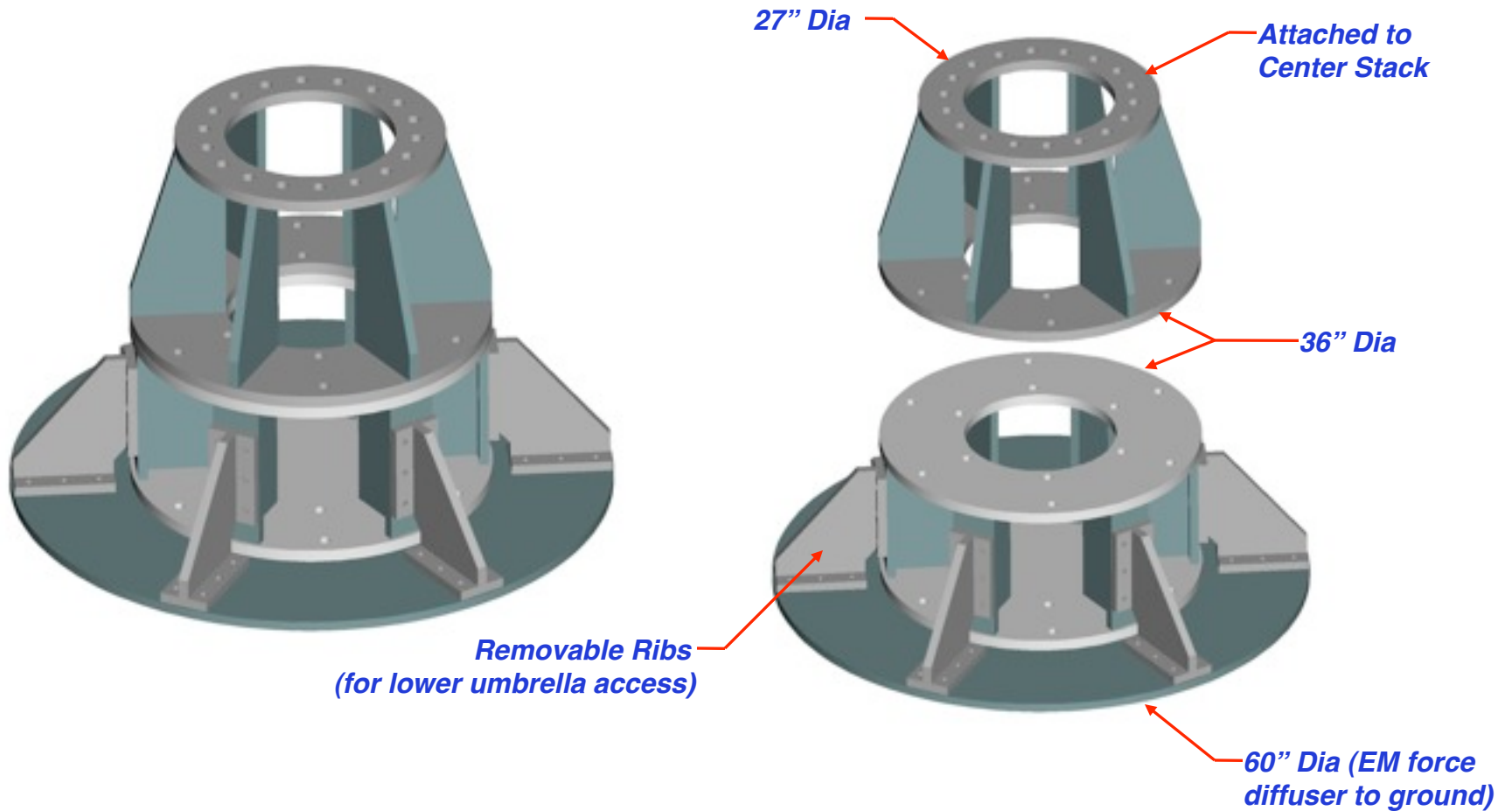

PF Coil Support Assembly

Item # in order of installation

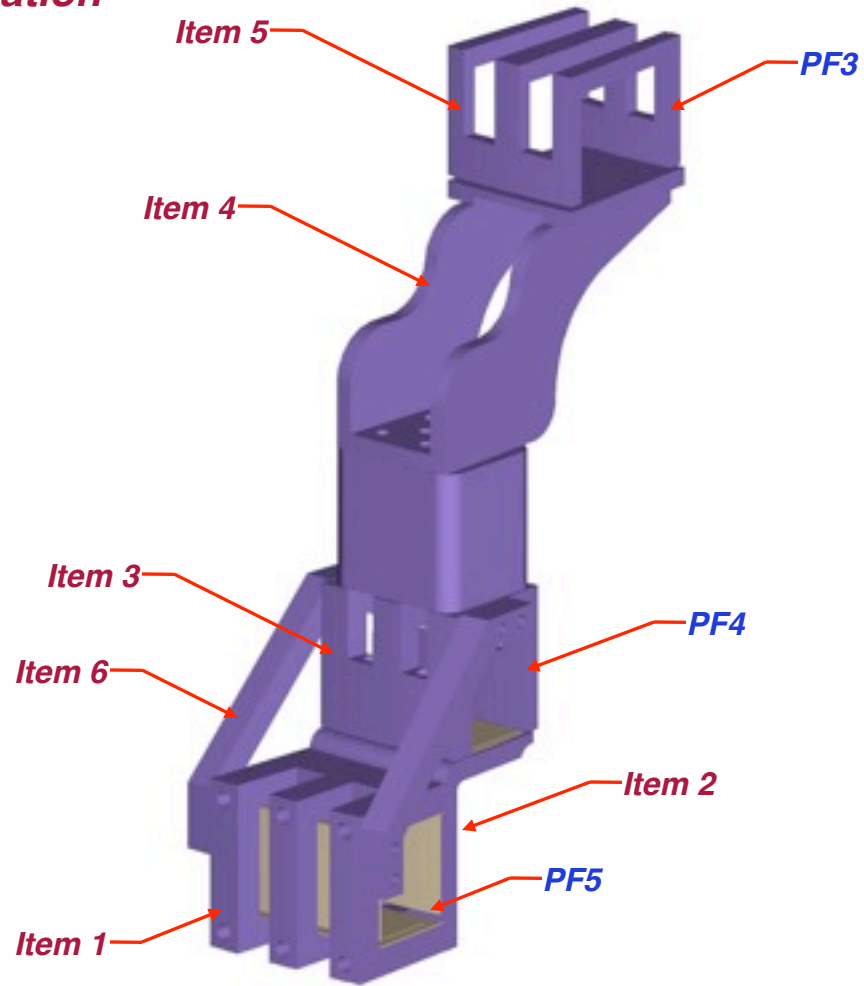

PF Cage – Coils Assembly with bottom support

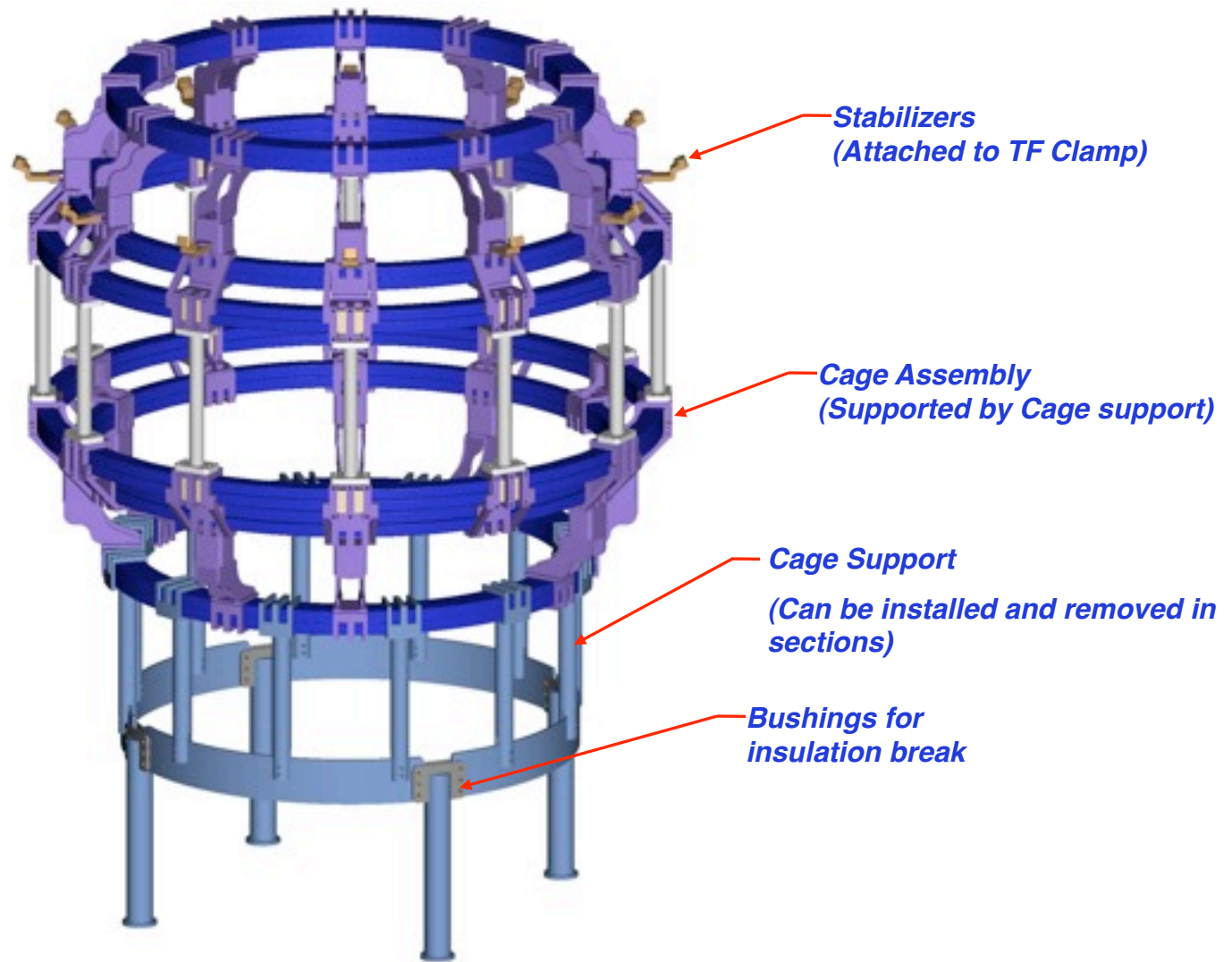

PF Cage Stabilizer

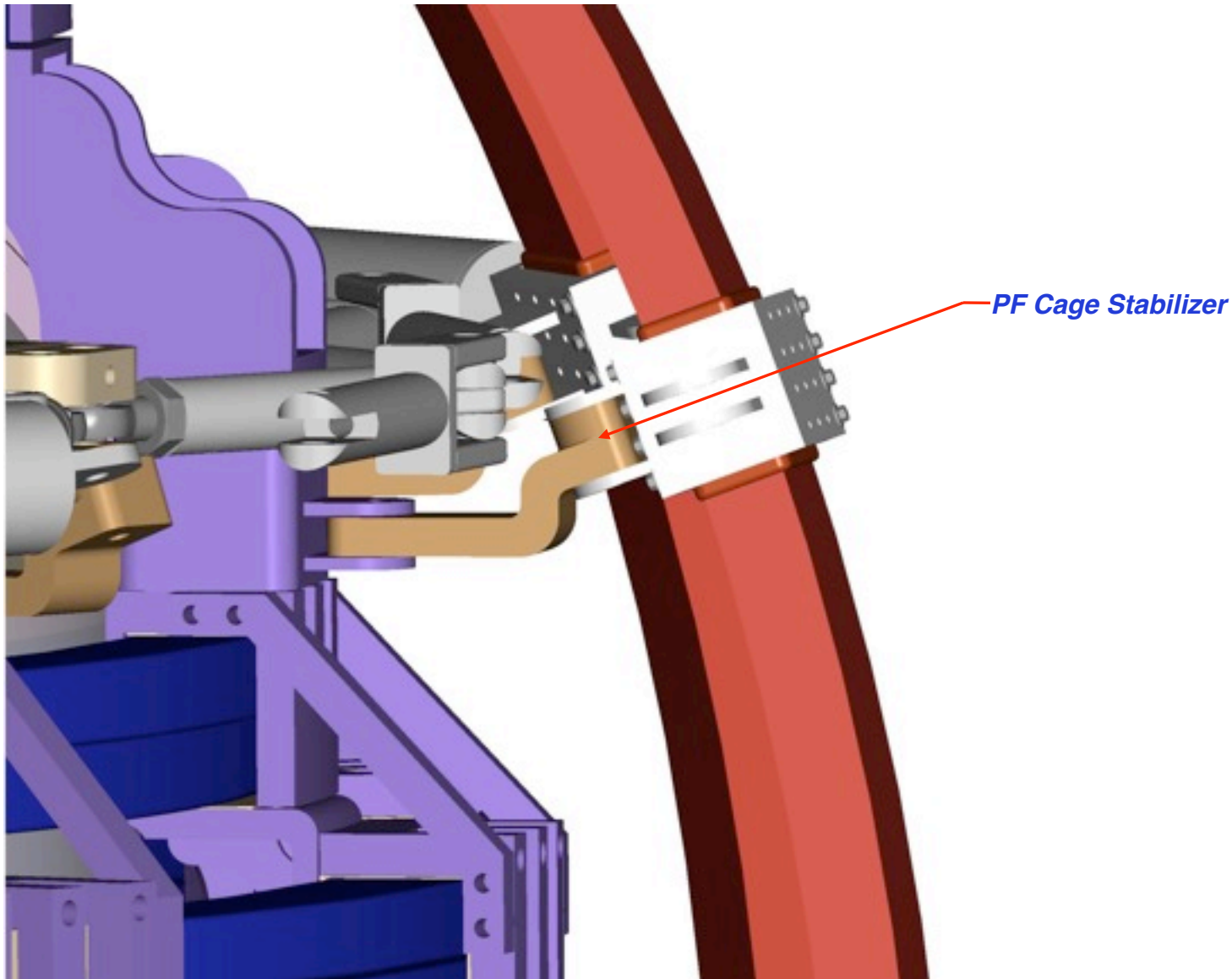

PF Cage to Floor Connection

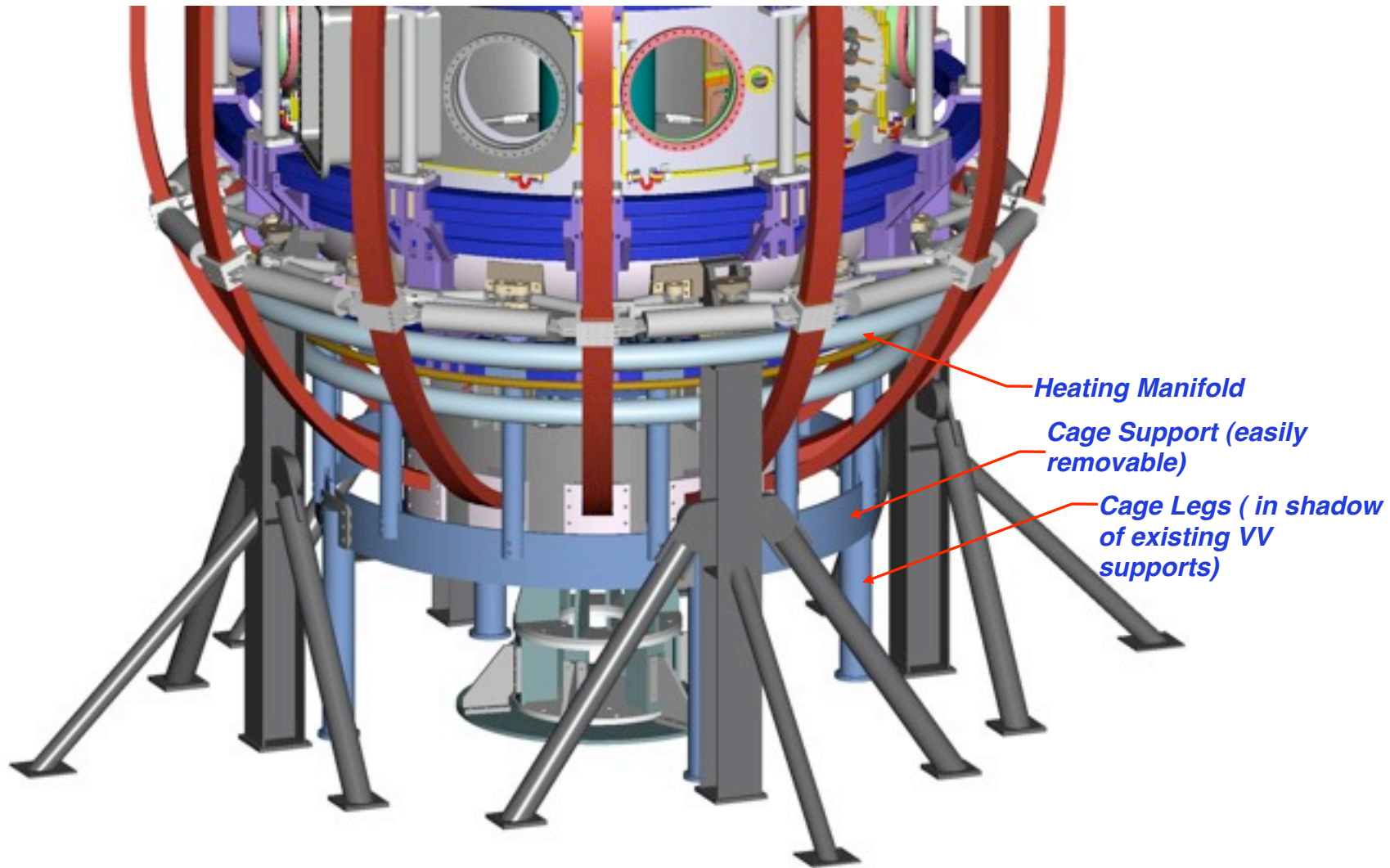

Installation Procedure Plan

- Install (TBD) Shaping fixtures to PF5
- Remove existing coil clamps on PF5 and PF4
- Upper PF5/PF4 are raised & Lower PF5/PF4 are lowered
- Inspect coils for repairs (leaks etc) & repair if needed
- Reposition upper PF5 & install PF5 cage clamps
- Link PF4 to PF5 via mechanical supports
- Add columns to PF5 and repositioned lower PF5
- Process continued on the lower coils
- Each coil is mechanical aligned for concentricity
- Leg system for the cage is attached
- Alignment system relative to legs of vessel is installed
- Cage system can be slid on ground (grouting plate to be designed)
- Align cage and bolt to ground/grouted plate
- Remove shaping fixture & alignment fixture
- Address electrical isolation/grounding needs

Issues

- PF2 Coil Support Structure - not yet started however the support should be straightforward
- Vessel stands
 - The launching loads on the vessel exceed the capability of the existing vessel connections so some reinforcement will need to be implemented
- Cage Support
 - Still evolving and being evaluated against all of the operational scenarios

Impacts

- Ribs on vessel need significant modification insitu
- Clevises on vessel must be removed and replaced with stronger versions
- Column Supports are installed inside the Outer TFs in 12 locations. Optimization may allow reductions.
- Additional supports for PF cage to the floor

SUMMARY

- **Concept Matured:**
 - PF3, PF4 and PF5 (upper and Lower) support structure
 - TF coils(12) support structure
 - Pedestal for center Stack
 - Both PF and TF coil supports are compatible with the NB2 Bay J/K modifications
- **Concept Pending:**
 - PF2 coils
 - Umbrella structure leg reinforcement
- **Issues- Real estate**
 - Difficulty to install the upgraded structure needs to be evaluated
 - Optimization is expected to identify opportunities for simplifications and cost savings