

Appendix I

Centerstack Fabrication and Assembly

NSTX-U Fabrication of the Centerstack Assembly



By: Jim Chrzanowski
October 2014

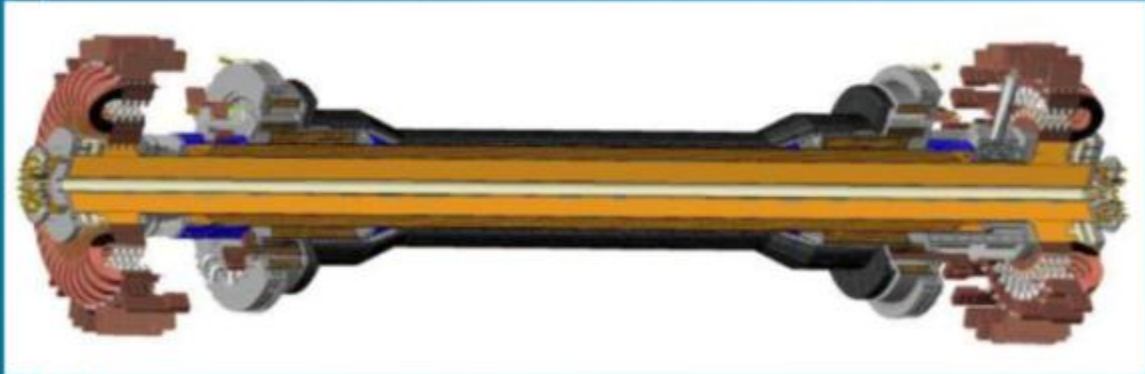



Prelude

- *This document provides a general overview of the manufacturing and assembly steps that were necessary to complete the Centerstack Assembly for the NSTX-U project.*

Introduction

- In 2009 the US Department of Energy approved the initiation of a project to update the NSTX for approved performance. A new Centerstack was included as part of the upgrade activities. The CS assembly includes:
 - Inner TF Bundle
 - Ohmic Heating Coil
 - Inner Poloidal Field Coils
 - Centerstack Casing
 - Plasma Facing Components

National Spherical Torus Experiment Upgrade (NSTX-U)

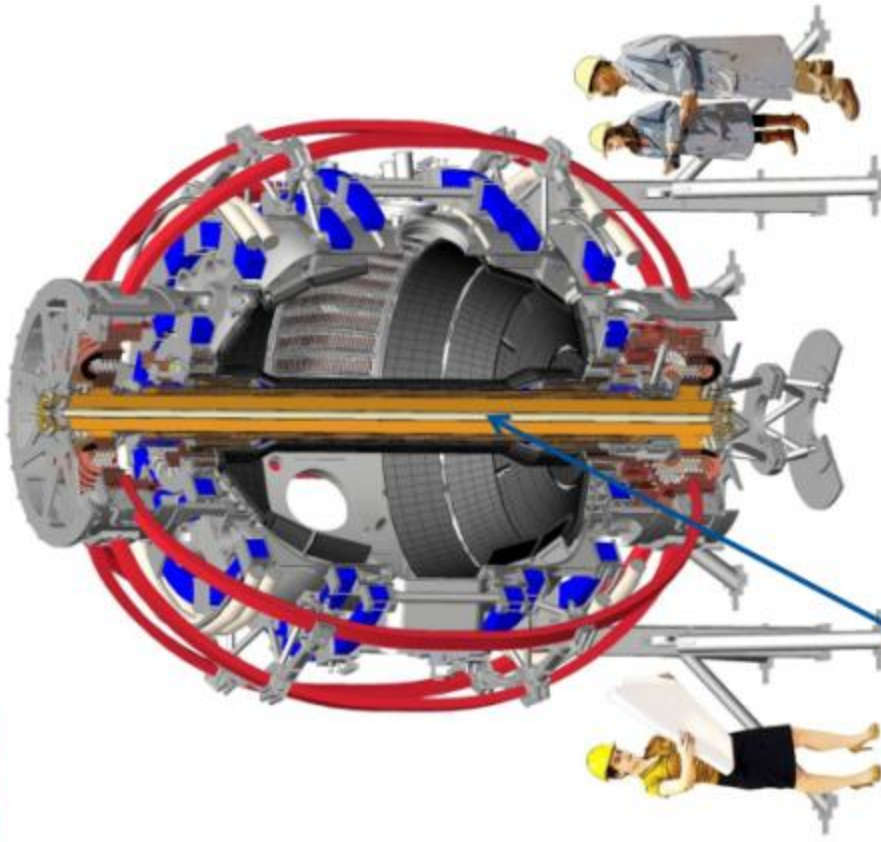

New Centerstack Assembly

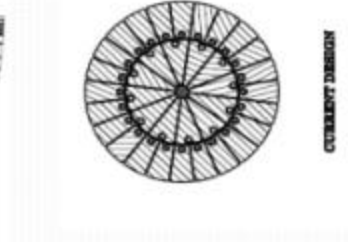
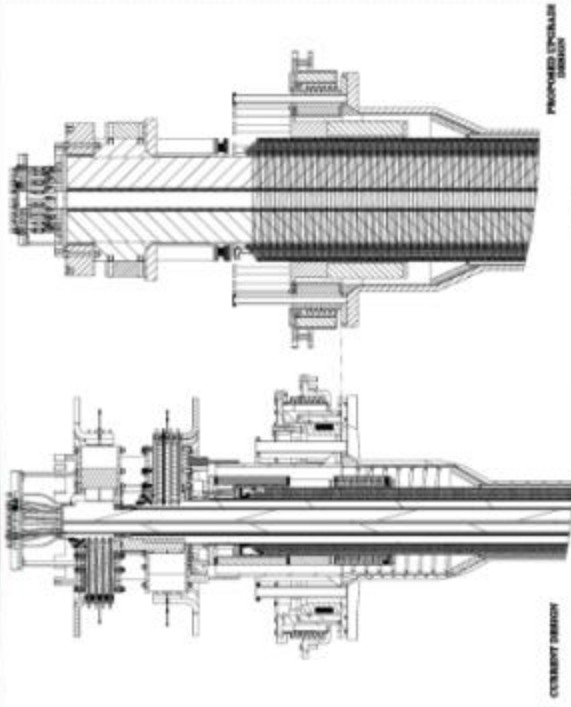

CURRENT DESIGN

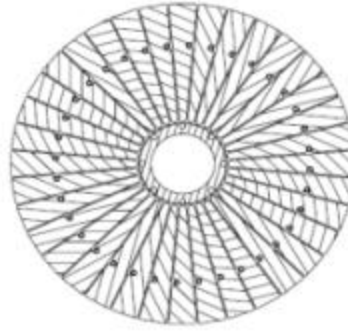

Original TF Bundle
7.9 inch diameter

Upgraded TF Bundle
15.7 inch diameter

NSTX-U Magnet Upgrade

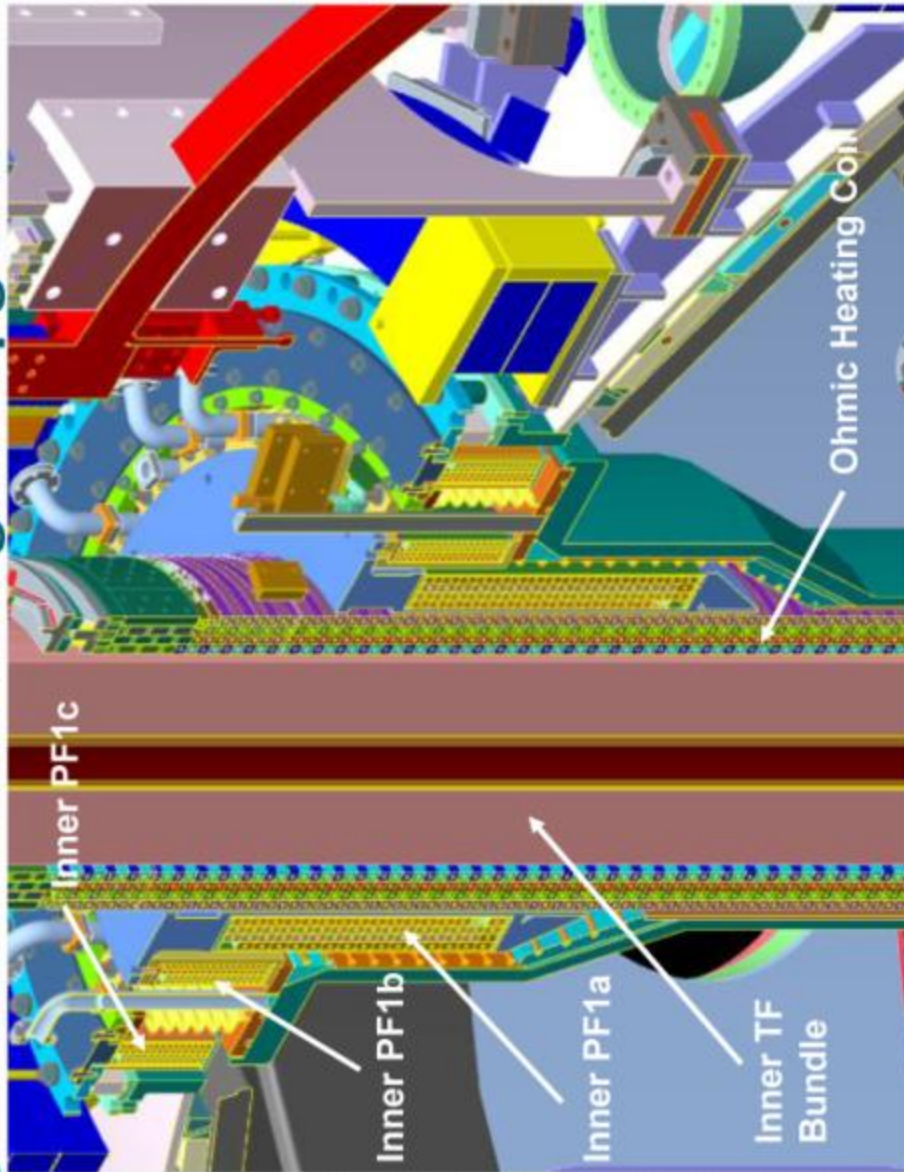

- New TF/OH coil- fabricated was by PPPL
- New Inner PF Coils were fabricated by Everson-Tesla



Inner TF Bundle

- **General Description:** The Inner TF bundle is a thirty six (36) turn copper coil bundle that forms the inner legs of the Toroidal field coil system. The coil is constructed using pie shaped oxygen-free silver-bearing copper conductors that are, sandblasted, primed and insulated with multiple half-lapped layers of S2 glass tape. Each conductor end has (CDA18150) Copper-Chromium-Zirconium lead extensions that were added via a friction stir welding [FSW] process. The coil was constructed into quadrants that allowed better dimensional control. Each quadrant of (9) conductors were epoxy impregnated using CTD-425 a 2-part system with Epoxy (EP) and Cyanate Ester (CE) catalyst in Part A and Cyanate Ester (CE) in Part B. The finished quadrants were then over wrapped with multiple half-lapped layers of S-2 glass insulation to form the outer ground-wall. The entire insulated coil was then epoxy impregnated using the CTD-425 system.



Inner Toroidal Field Conductors

- Inner TF copper extrusions were procured from Luvata-Pori, Finland
- Oxygen-free silver-bearing copper CDA10700

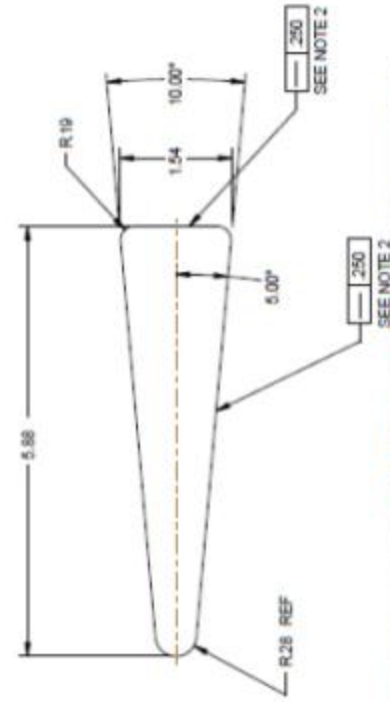

Inner Toroidal Field Conductor Assemblies

- The contract for manufacturing the Inner TF conductor assemblies was awarded to Major Tool located in Indianapolis
- The manufacturing was a (3) step process.
 - Initial machining by Major Tool
 - Friction Stir Welding (FSW) of the coil leads to the TF conductor was subcontracted to Edison Welding Institute, located in Columbus, Ohio.
 - Final machining of the completed conductor was then performed by Major Tool

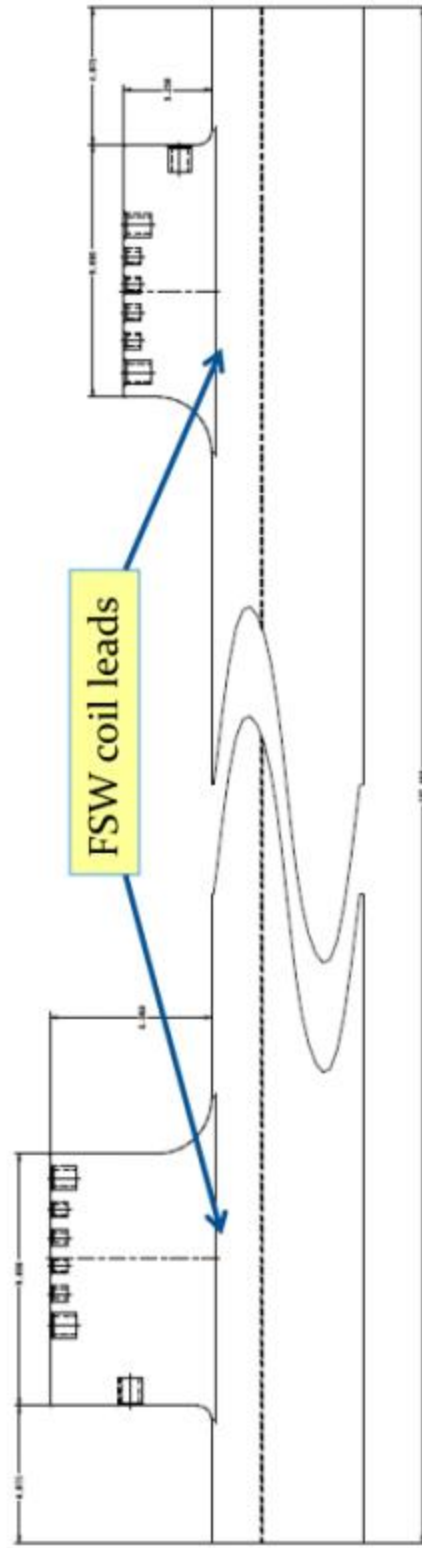

TF Conductor Assembly Manufacturing Sequence



TF Conductor Friction Stir Welding

High strength coil leads, Copper-Chromium-Zirconium (CDA18150) were added to each end of the oxygen free silver-bearing copper conductors (CDA10700) by a process known as friction stir welding (FSW). This work was completed by Edison Welding Institute (EWI) in Columbus, Ohio



Finished Inner TF Conductor Assembly

Completed TF Conductor Sub-Assemblies in Major Tools Quality Control Inspection room.

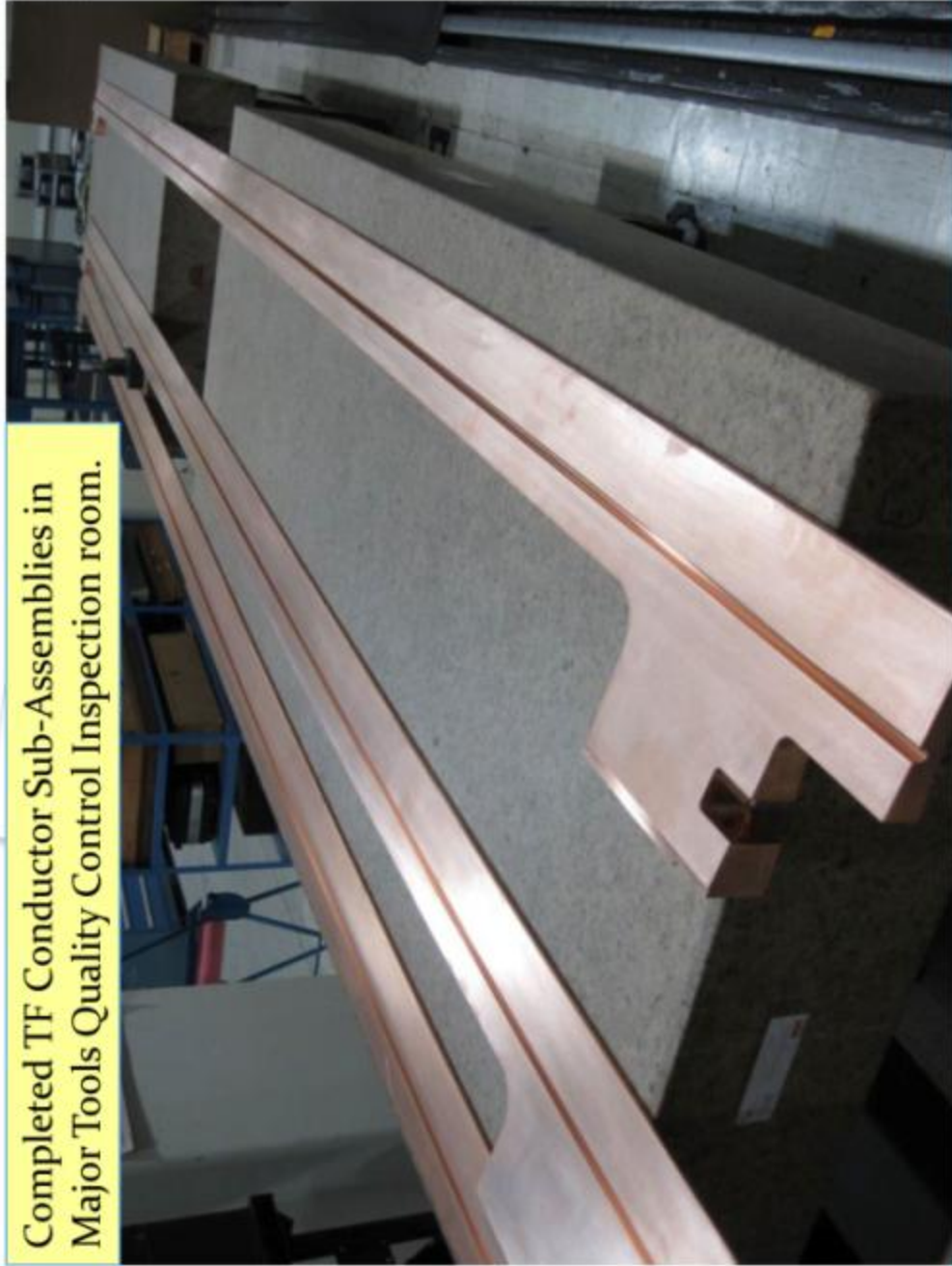

Delivery of TF Conductor Assemblies



The finished TF Conductors were delivered to PPPL via truck from Major Tool located in Indianapolis, Indiana

Soldering Operation



The copper cooling tubes were soldered into the TF conductor assemblies using Solder paste- 96.5 Sn / 3.5 Ag w/ GMS based "R" flux [*Glyceryl Mono-stearate, Terigitol (a detergent) and Cyclohexamine Hydro-bromide*]

TF Conductor Preparation

Conductors were Post Solder Baked to 170° C to remove any excess flux



Prime conductors w/CTD-450 primer & Cured



Grit blast conductors

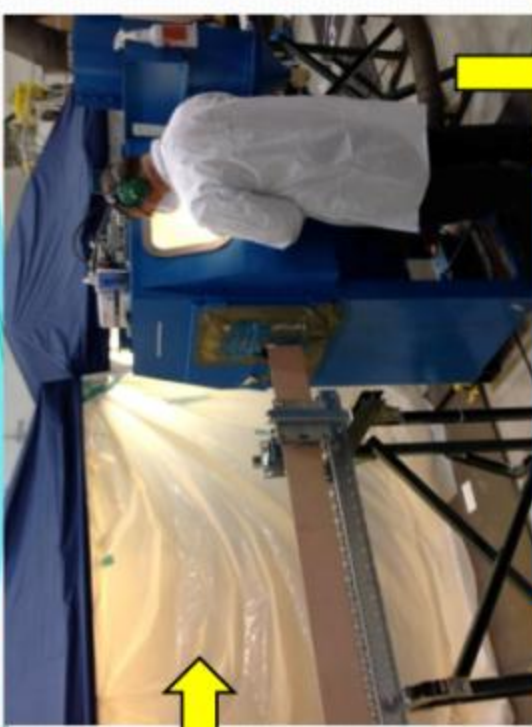

Applying S-2 Glass TF Turn Insulation



Assembly of Inner TF Quadrants



Assemble (9) individual conductors into each Quadrant mold

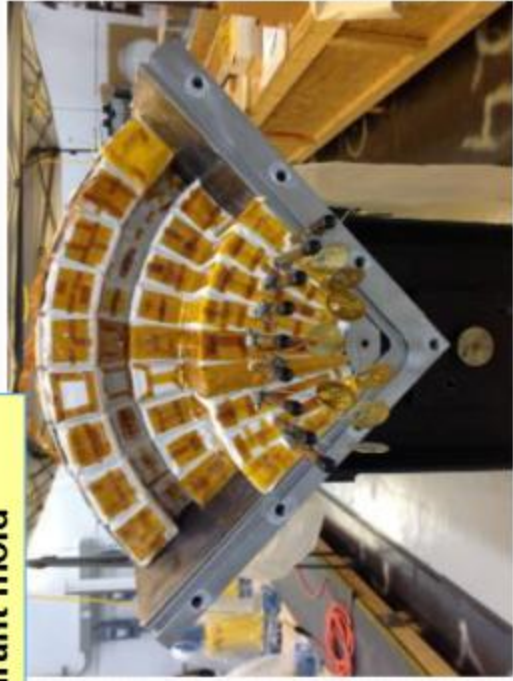

Assembly of Inner TF Quadrants

- Once the conductors were assembled into the mold, each TF Quadrant was successfully Vacuum Pressure Impregnated (VPI) using CTD-425 epoxy system

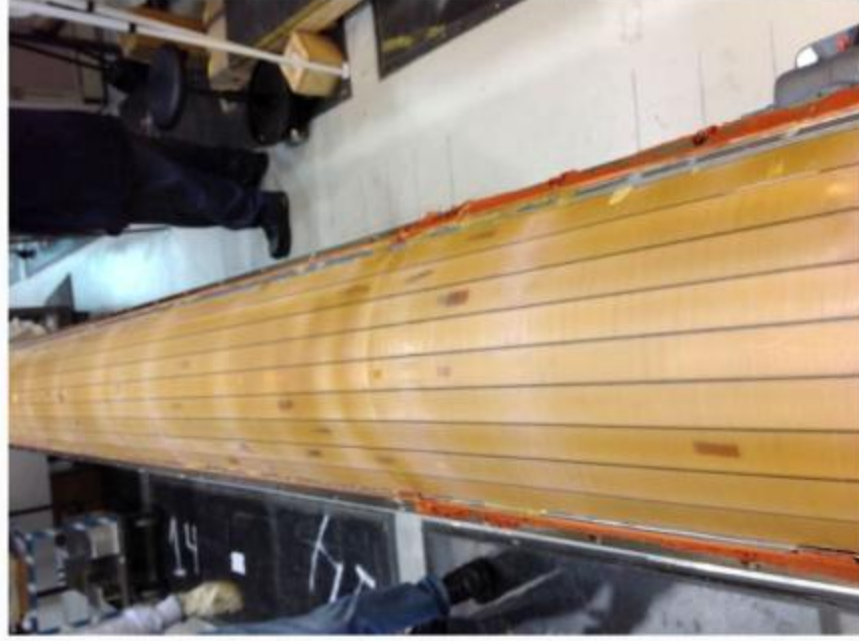

TF Quadrant Electrical Tests

- Each of the (4) TF Quadrants successfully passed their electrical acceptance tests.

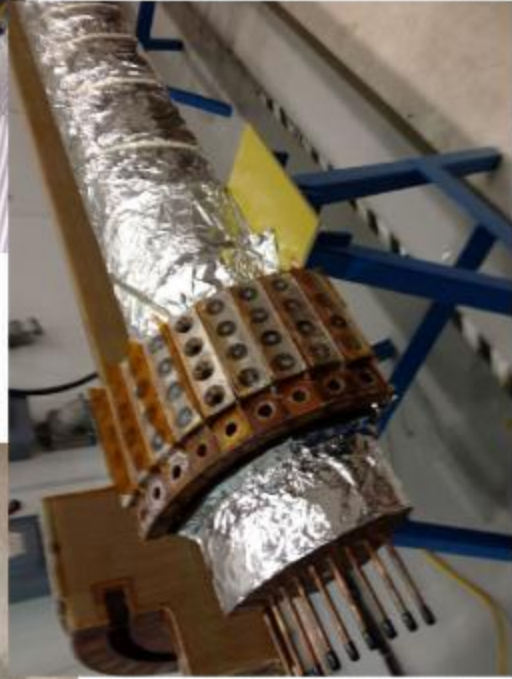

Completion of First TF Quadrant



Assembly of Full TF Bundle

- The four VPI's quadrants were then assembled together to complete the full bundle.

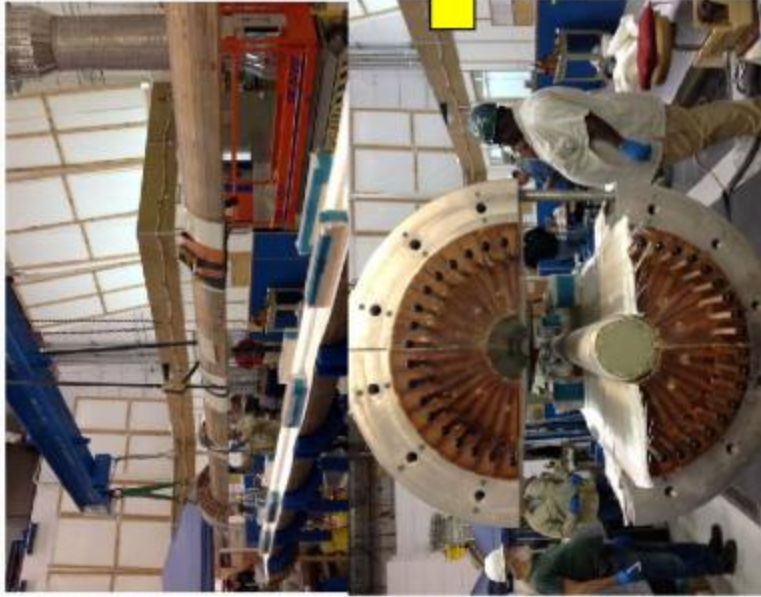

The quadrants will be assembled w/ S-2 between layers & pre-insulated G-10 core



The full TF bundle is placed into a mold and VPI'd



The full TF bundle is Ground wrapped with S-2 glass tape

Full TF Bundle VPI'd



Full TF Bundle in oven and ready for VPI

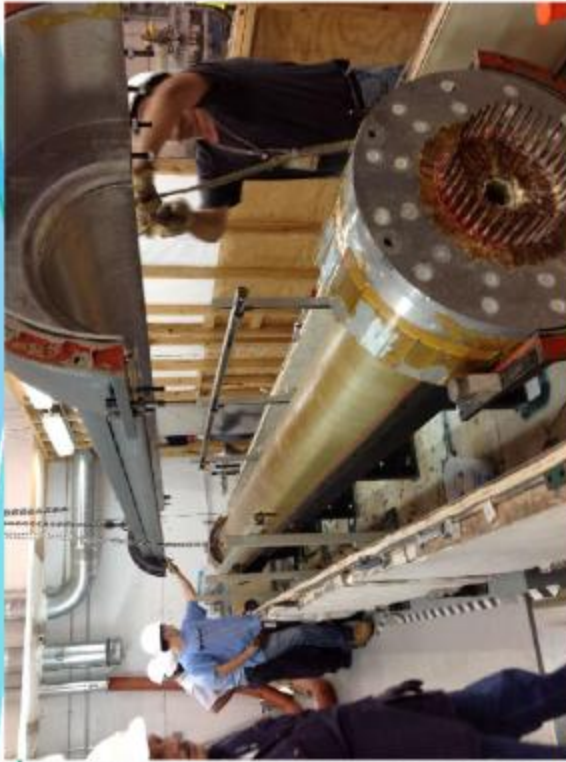

Full TF Bundle after VPI



Full TF Bundle Electrical Tests

- The Full TF Bundle successfully passed its electrical acceptance tests.

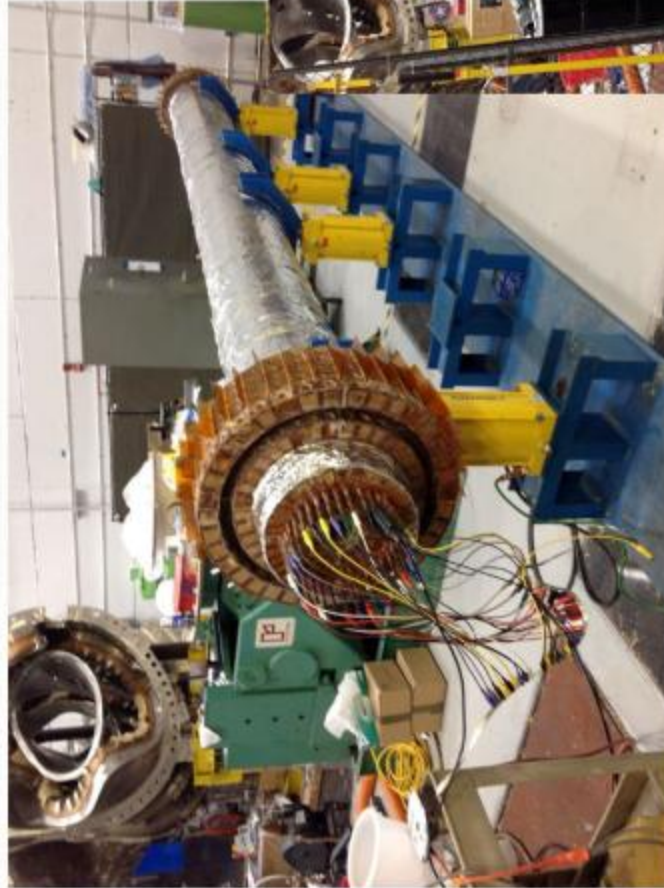

Raising the Full TF Bundle

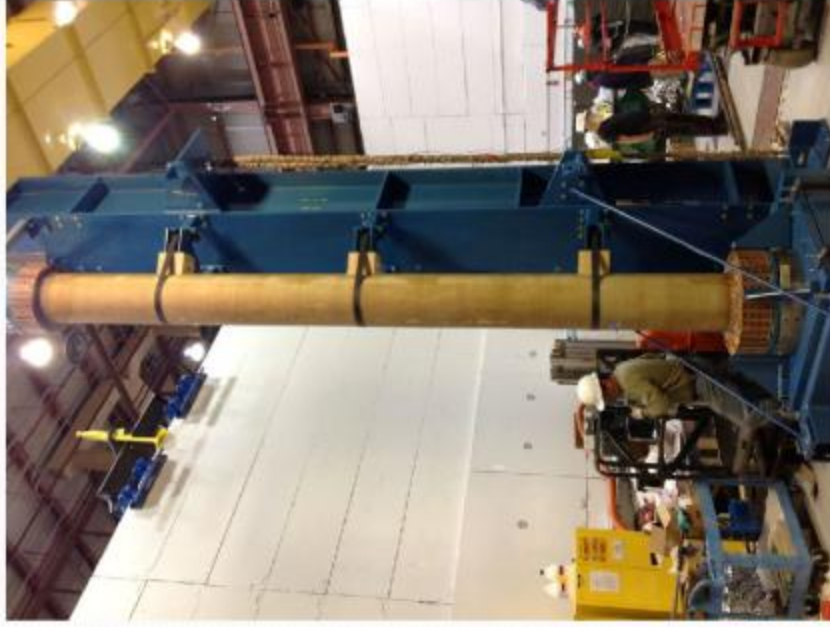

- Following testing, the Inner TF Bundle was transported to the vertical positioning fixture.
- The TF Bundle was raised to the vertical position in preparation for the application of the Aquapour.

Installation of Aquapour Layer

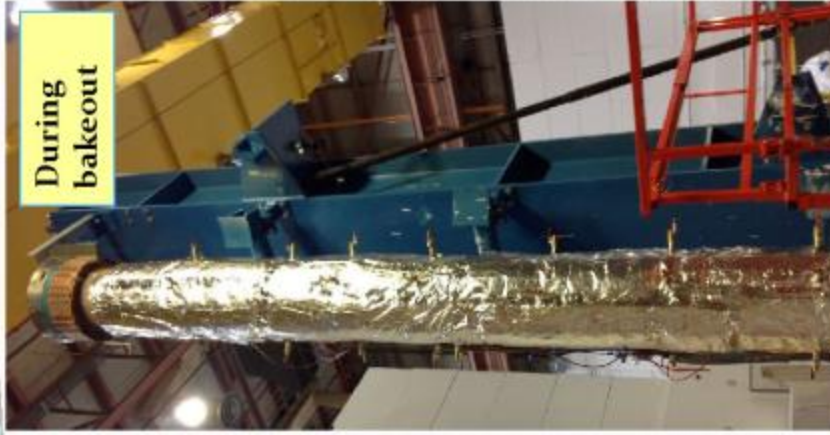
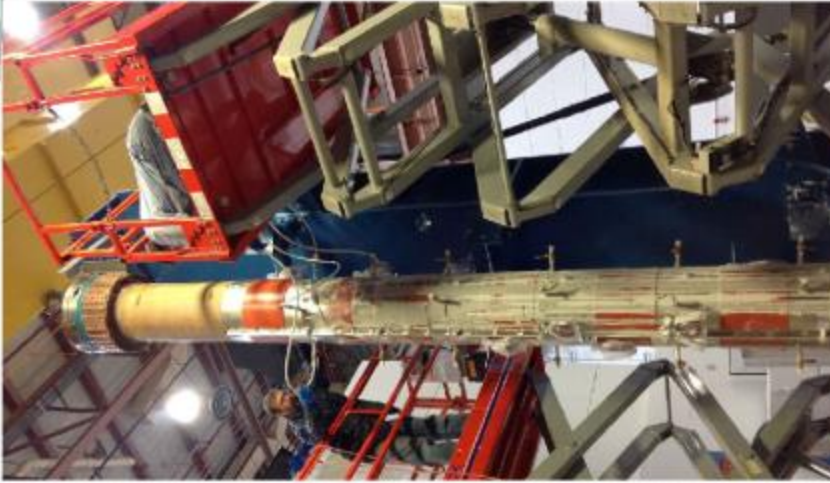
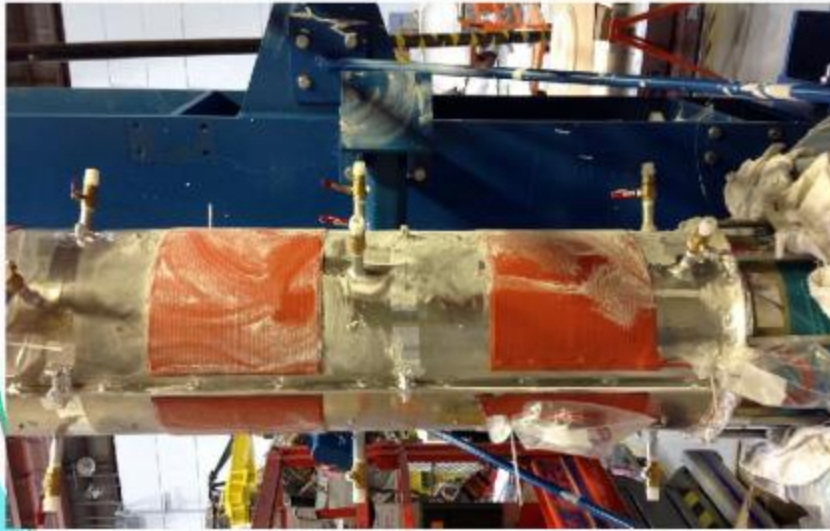

- Installation of Aquapour layer was successfully completed

“Aquapour” is used as a temporary spacer that will be used to maintain 0.100 inch gap between the TF OD and OH ID surfaces. It is removed post VPI of OH coil

OH Winding Preparations

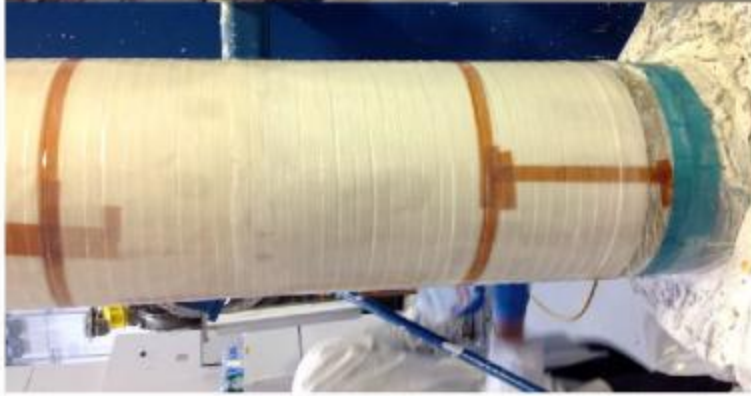

Epoxy/glass layer was applied over the Aquapour surface to provide a solid winding surface

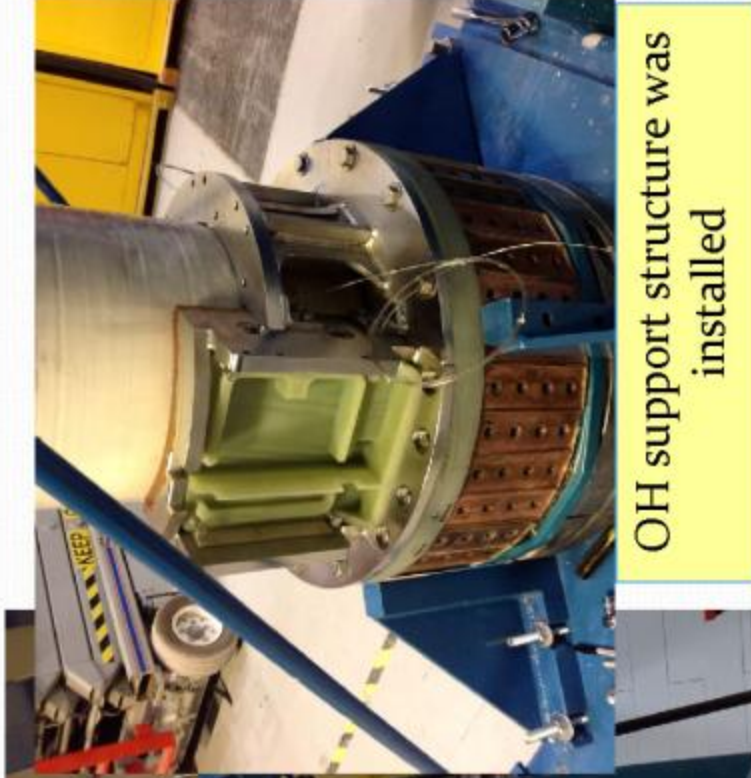

OH support structure was installed

Transfer TF to OH Winding Station



• The TF bundle was transferred to the OH Winding station



Applying Inner ground wrap insulation



OH Winding Station Pivot Beam

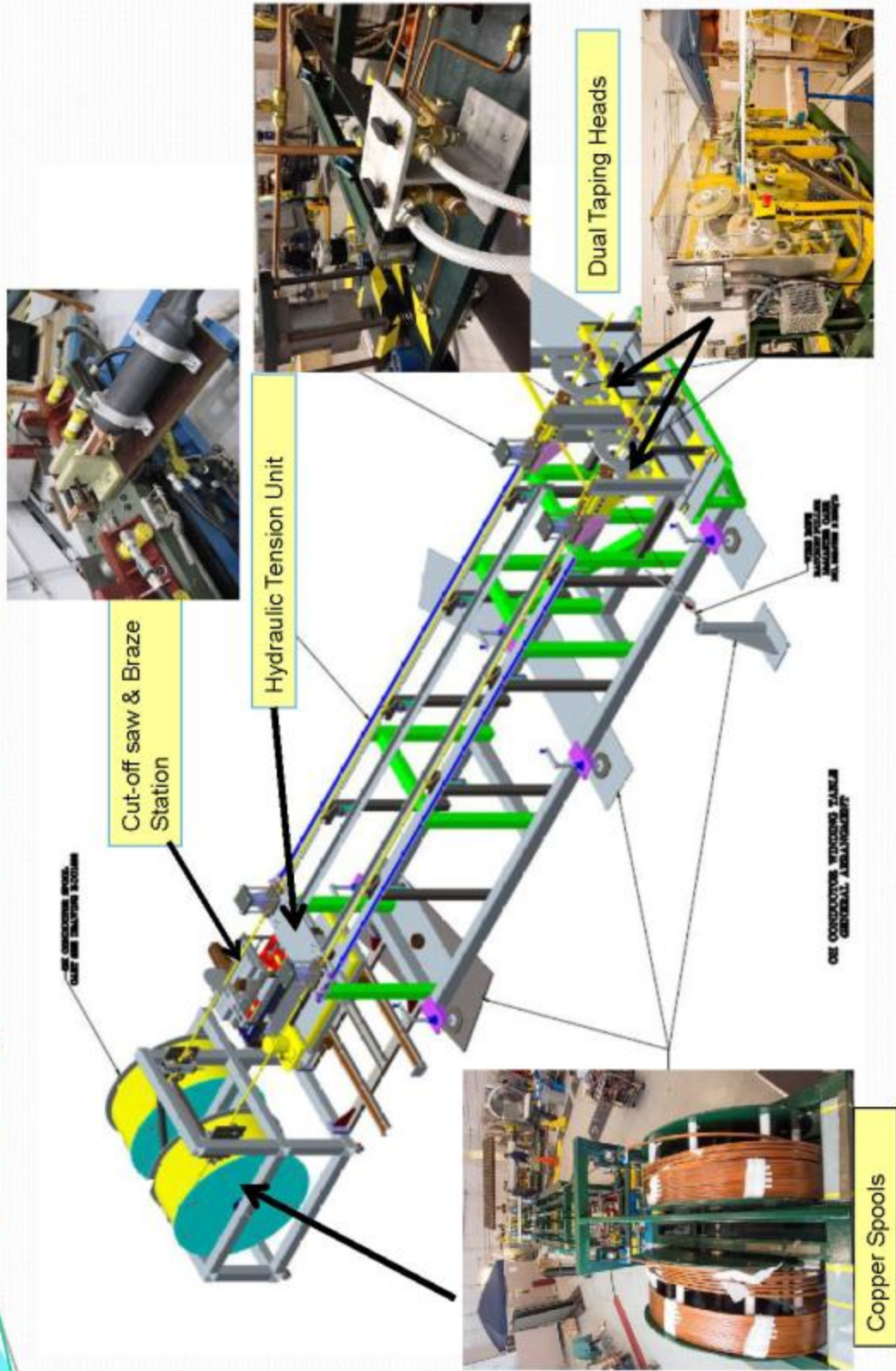

Ohmic Heating Solenoid

- **General Description:** The Ohmic Heating (OH) solenoid is a 4-layer [884 turn] copper coil. The coil was constructed using extruded oxygen-free silver-bearing copper conductor w/cooling hole. The conductor is first grit blasted and primed, similar to the TF conductors. Individual turns were insulated with co-wound glass/Kapton insulation applied in multiple half-lapped layers. The OH solenoid conductor was wound (2-in-hand) over the outside diameter of the inner TF coil bundle. A 0.100 inch gap was maintained between the OD of the TF bundle and the ID of the OH solenoid to allow for thermal growth of the components. S-2 glass ground-wrap was then applied over the finished wound coil. The entire wound coil was then epoxy impregnated using CTD-425 system a 2-part system with Epoxy (EP) and Cyanate Ester (CE) catalyst in Part A and Cyanate Ester (CE) in Part B.



OH Coil Lead & cooling fittings were Torch Brazed to OH Conductor



OH Winding Station



OH primed Conductor



Coil Winding Activities

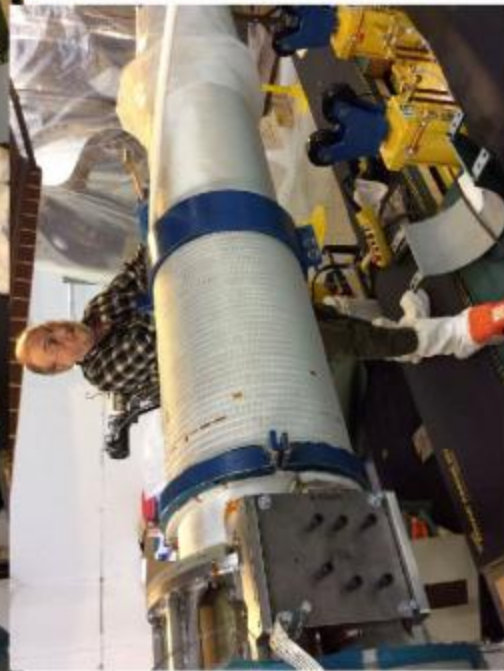
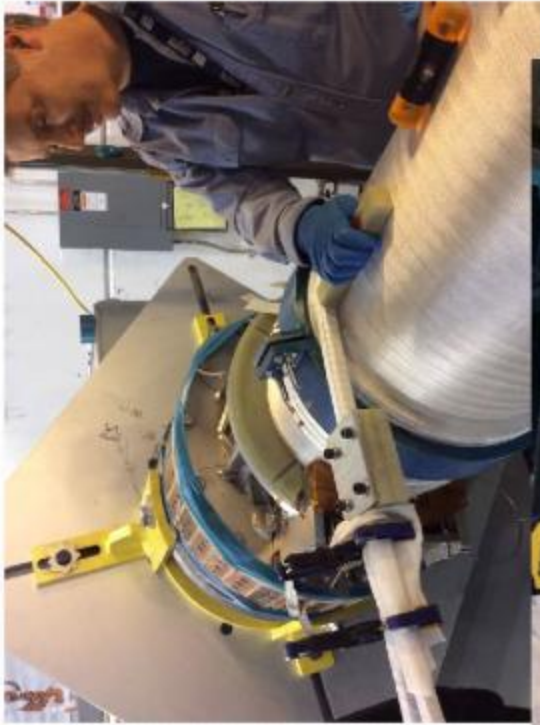

Coil Winding Photos - continued



Photos of some of the winding activities and personnel

OH In-Line Brazing

- (32) in line brazes were performed during the OH winding operations.
- Each braze joint was mechanically loaded (stretched) and helium leak tested to ensure a quality braze joint.

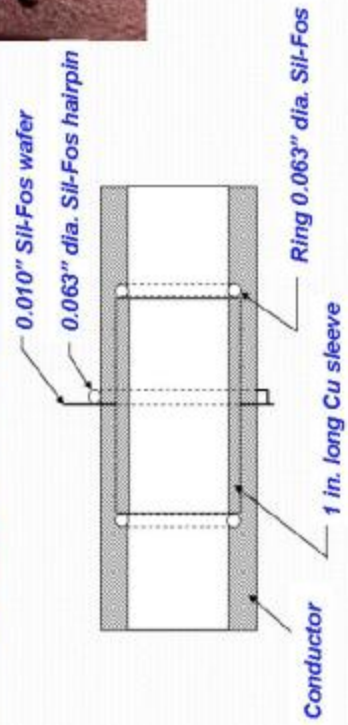

OH Coil Fillers

- The OH insulating fillers located at each end of the OH coil were fabricated in-house using a wet layup process with glass tape and CTD-425 resin system.
- The cured fillers were then machined and cut to fit the layer to layer transition areas

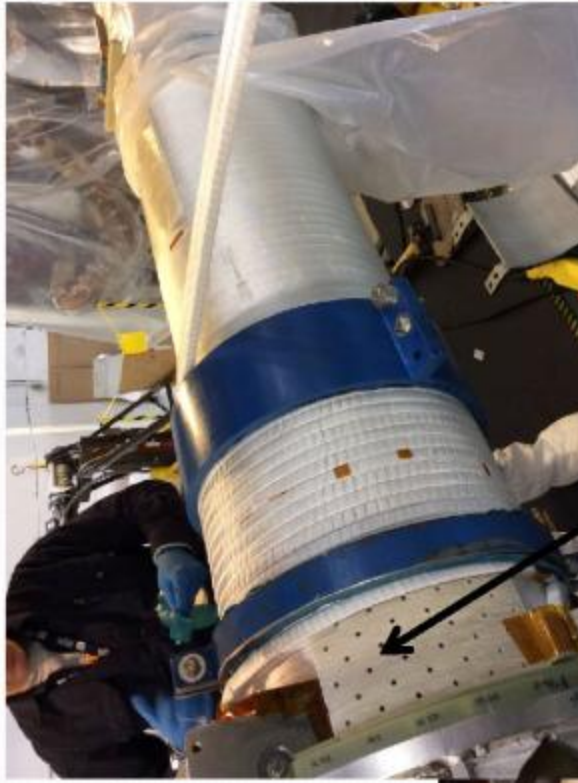

OH Fillers

Completion of Coil Winding- OH Winding Team



Most of the OH coil winding team members

Ground-wrapping OH Coil

- Multiple half-lapped layers of 2 inch wide glass tape were hand applied over the OH coil diameter to form the outer ground wall.



VPI & Electrical Testing of OH Coil

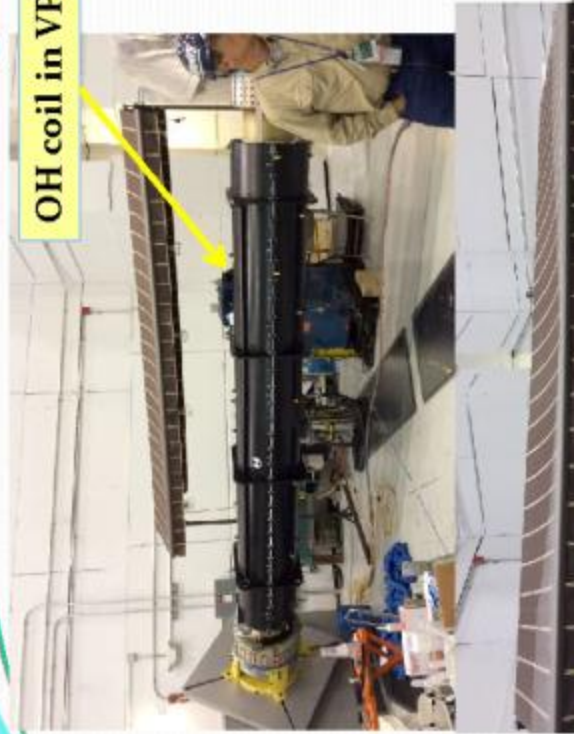

OH coil in VPI mold

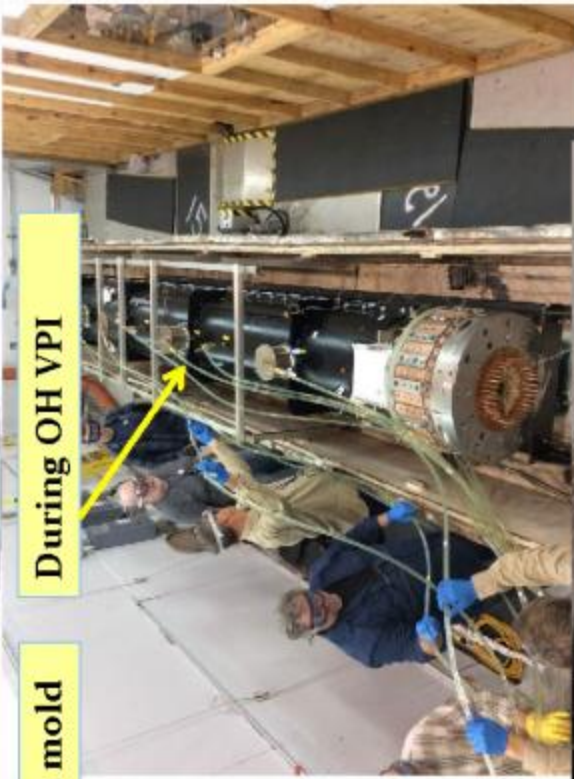

During OH VPI



The coil was successfully VPI'd and electrically tested



Outer Ground-plane and Pre-load Assembly

- The “Aquapour” could not be removed as planned because epoxy had migrated into the “Aquapour” material. Project decision was made to abandon “Aquapour” in place.
- The outer surface of the OH coil was then painted with a ground-plane coating.
- The Belleville washer pre-load assembly was then installed



Ground-plane outer coating



Belleville washer pre-load assembly

Center-stack Nearing Completion- NSTX-U

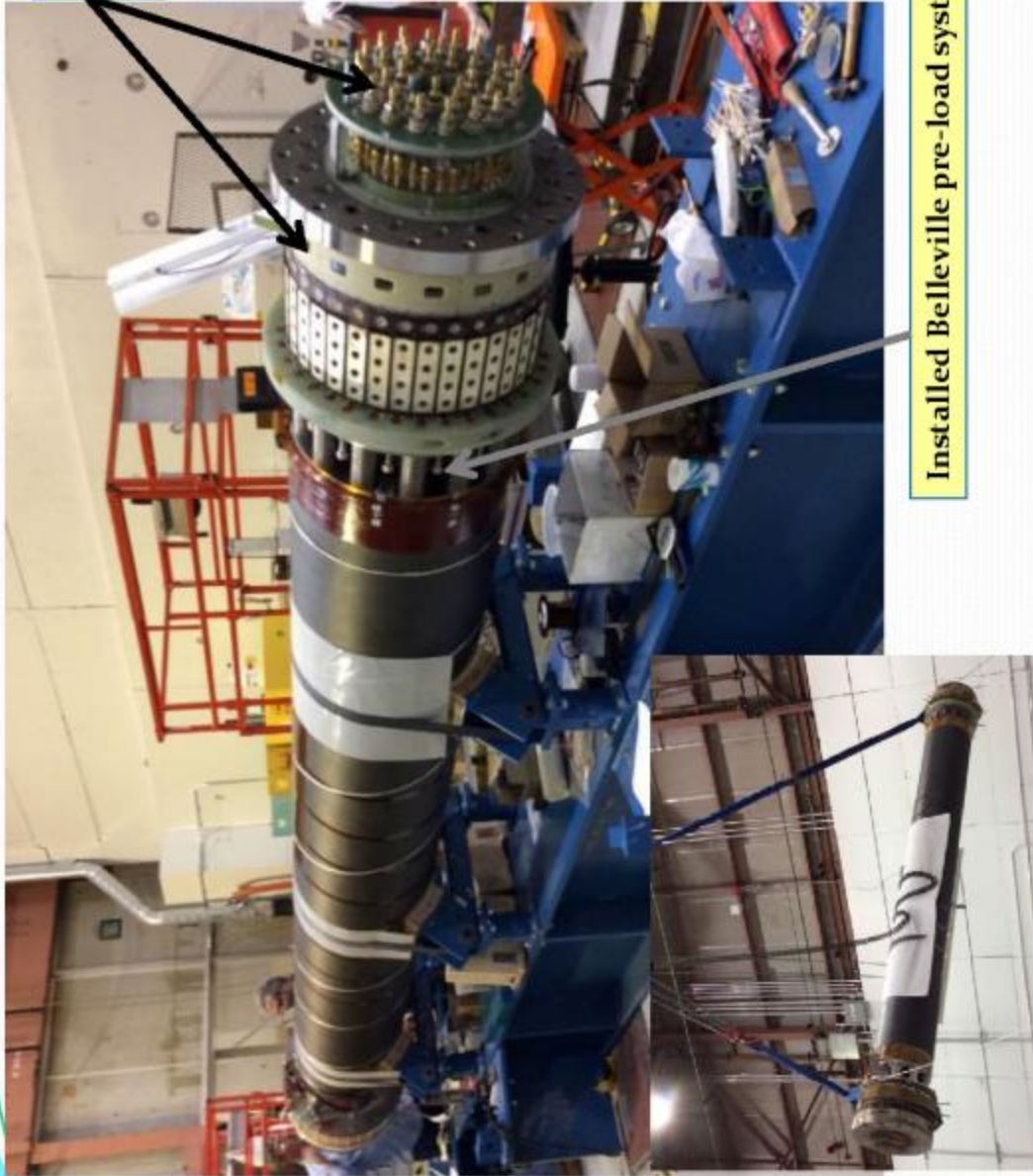

Finalized Inner TF cooling fittings and G-10 torsion crowns



Installed Belleville pre-load system

Raised OH/TF Bundle for final assembly details

The OH/TF bundle was raised to the vertical position so that the surface diagnostics and micro-therm thermal blanket could be installed.



OH/TF Bundle weighs approximately 23,000 pounds without PF coils or casing



Installing Lower PF1A Coil Assembly



PF1A coil weighs approximately 1800 pounds

- PF1A had to be lowered over the entire length of the OH/TF bundle prior to the installation of diagnostics



Installed OH Diagnostics and Thermal Blanket

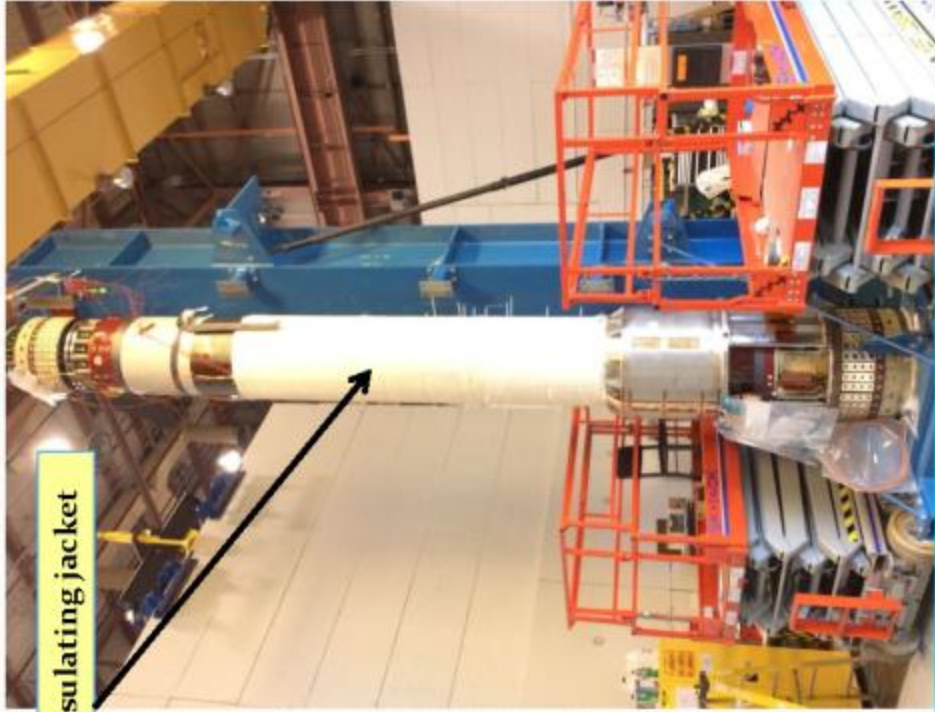

Micro-therm insulating jacket

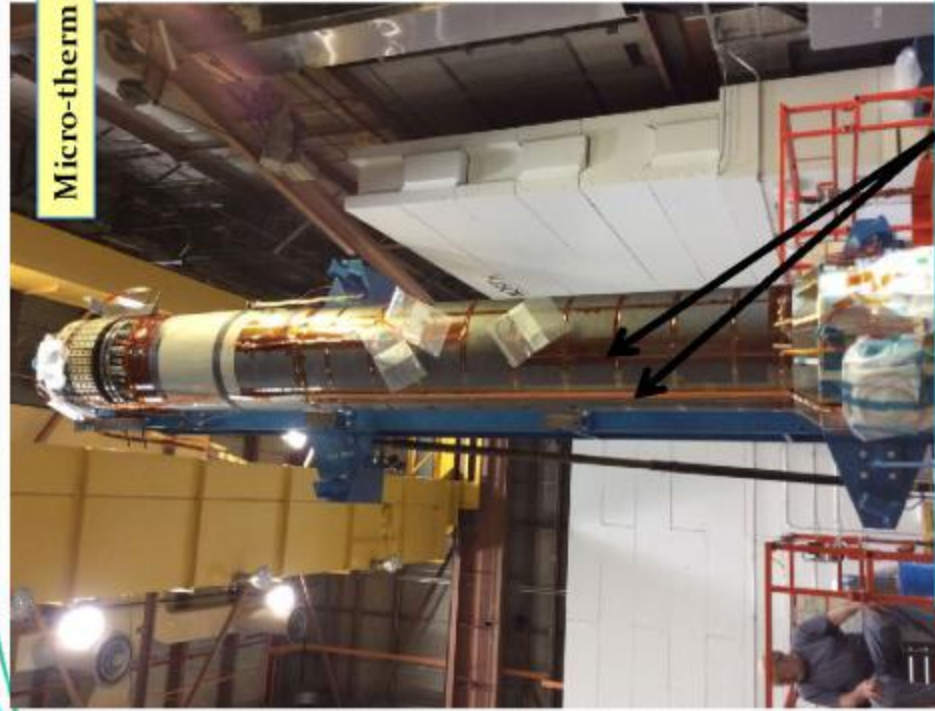

Surface diagnostics include- flux loops, thermocouples and (3) Rogowski coils

Lower OH/TF Assembly & Prepare for Transport



Quality Trademark



OH/TF Assembly Ready for Transport to D-Site



Transport OH/TF Assembly to D-Site



Centerstack Casing

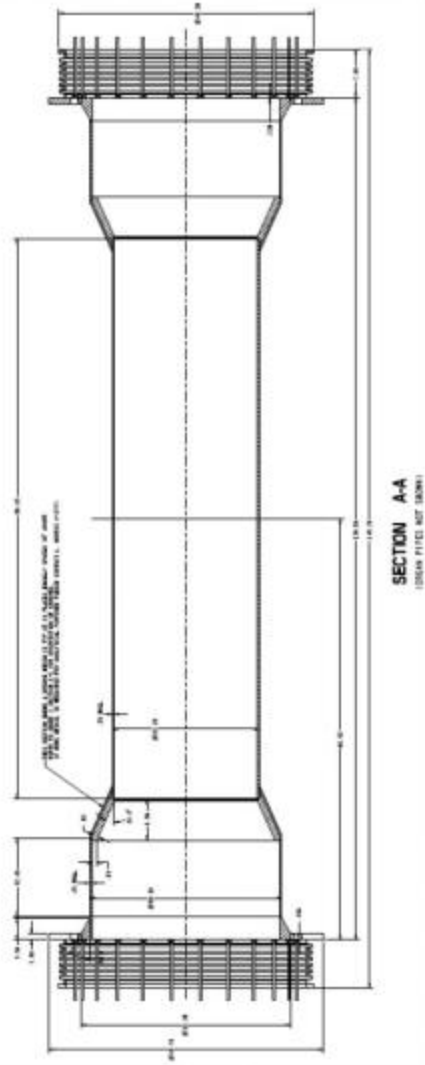

- The Centerstack casing and bellows are fabricated using Inconel 625 and provides the inner vacuum vessel wall for the NSTX vacuum vessel. It also provides the structural support for the plasma facing components and surface diagnostics. Active cooling in the IBD regions has been incorporated in the upgrade.
- The casing was fabricated by Martinez-Turek, Inc. in California

Center Stack Casing Fabrication



fabricated by Martinez-Turek, Inc.

Tile Installation on Casing



- Carbon tiles and diagnostics were added to the surface of the Centerstack casing by PPPPL personnel.



Inner Poloidal Field Coils

- **General Description:** Includes three pair of Poloidal Field coils [PF_{1A}, PF_{1B} and PF_{1C}]. These coils were constructed using extruded oxygen-free silver-bearing copper conductor w/cooling hole. Individual turns are insulated with co-wound glass/Kapton insulation applied in multiple half-lapped layers. Multiple half-lapped layers of S₂ glass ground-wrap is applied over the finished wound coils. The wound coils were epoxy impregnated using epoxy impregnated using CTD-425 system a 2-part system with Epoxy (EP) and Cyanate Ester (CE) catalyst in Part A and Cyanate Ester (CE) in Part B.
- The Poloidal Field coils were wound directly onto their support structure and VPI'd into the structure.
- The Inner PF coils were fabricated by Everson-Tesla Co.

Fabrication of Inner Poloidal Field Coils

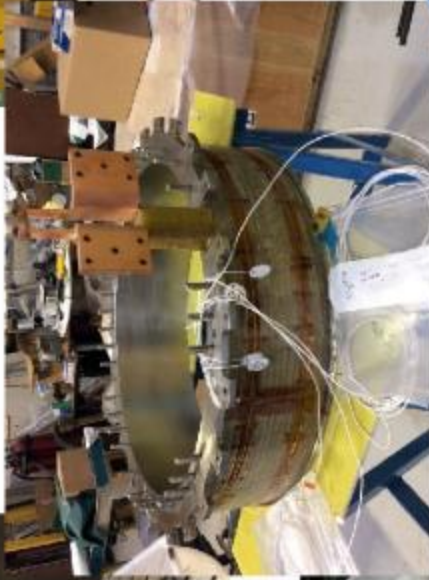

Installation of CS Casing with OH/TF Bundle

- Photos of the Centerstack casing being lowered over the OH/TF bundle



Installation of Upper PF1A Coil

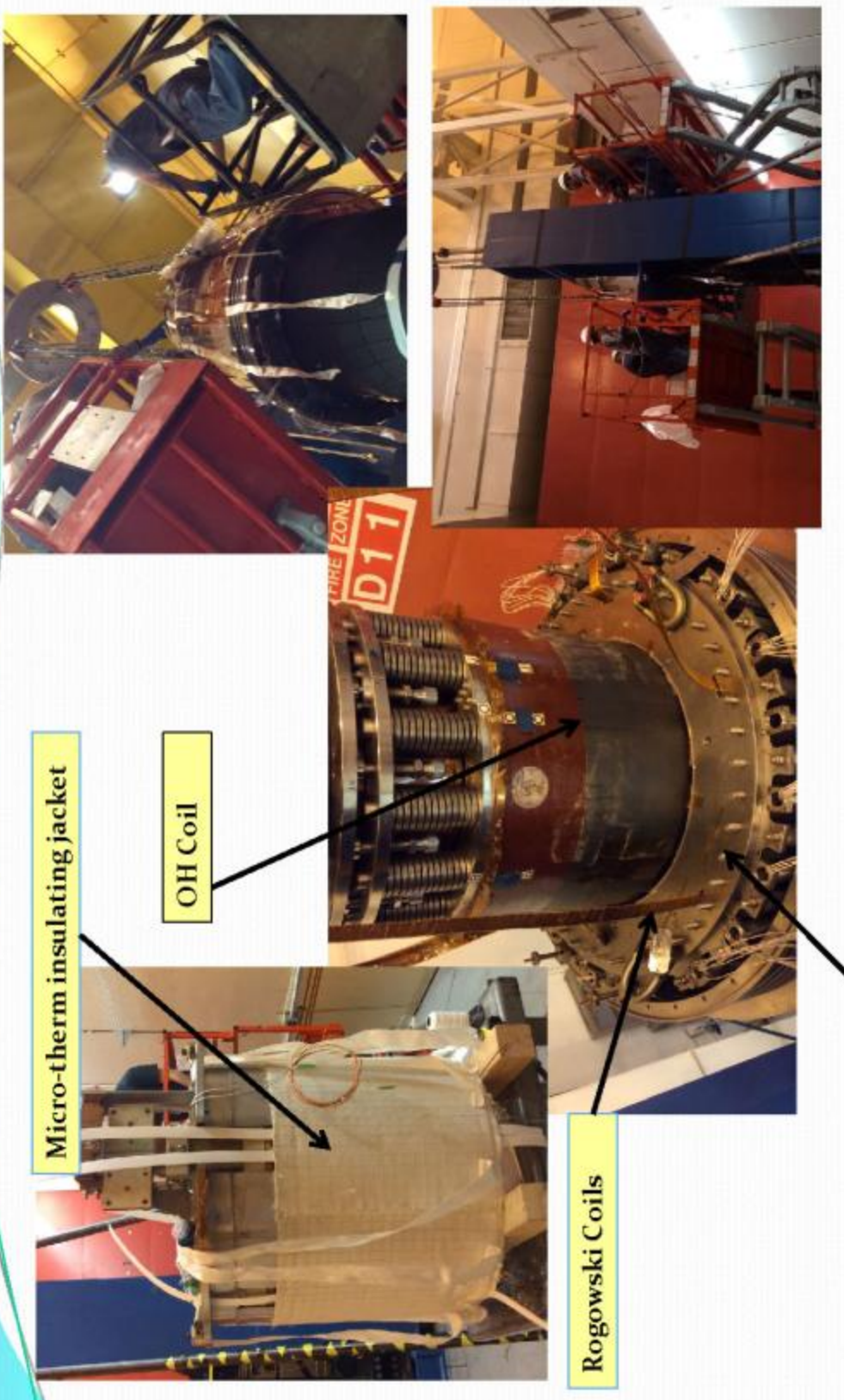

- The PF1A was installed on the upper end of the Centerstack Assembly

Final Installation of the New Centerstack Assembly



- The Completed Centerstack Assembly was installed into the NSTX vacuum vessel on **October 24, 2014**
- The full Centerstack with rigging weighs less than **30,000 pounds**



Final Installation of the New Centerstack Assembly

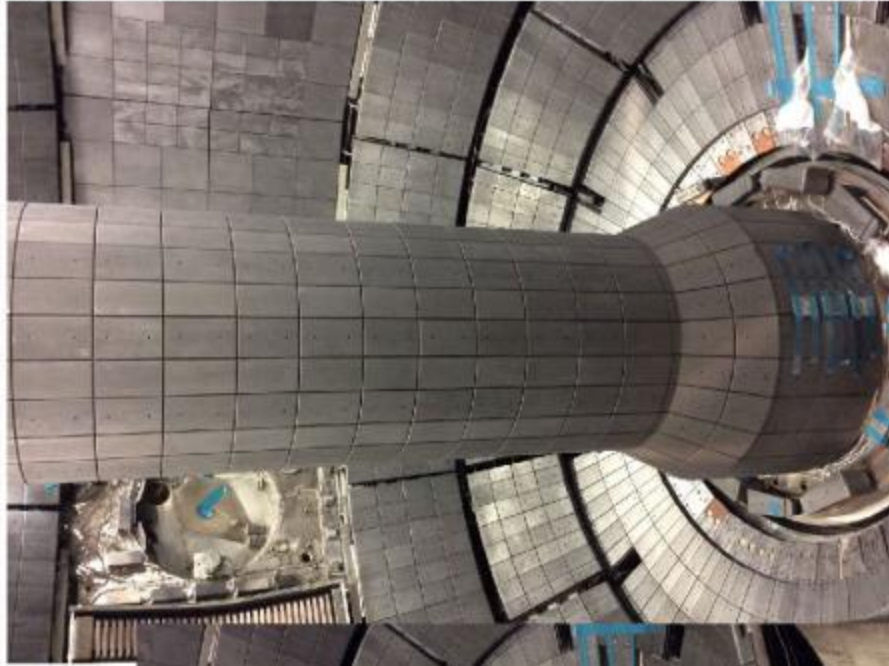
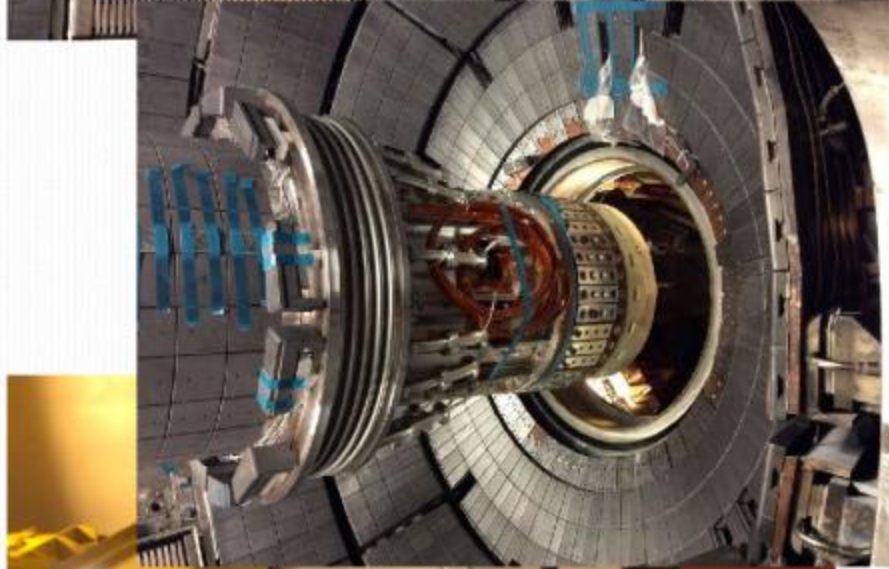

• Installation photos