

NSTX Upgrade Project

STRUCTURAL CALCULATION OF THE TF FLAG KEY

NSTXU-CALC-132-08-02

Rev 1 December 05, 2011

Prepared by Ali Zolfaghari Dec 20 2011

Reviewed by Tom Willard Jan 3 2012

Rev 2 September 2014

Rev 2 Prepared By:

Peter Titus, PPPL Mechanical Engineering

Rev2 Reviewed By:

Ali Zolfaghari

Rev 2 Reviewed By:

James Chrzanowski, NSTX Cognizant Engineer

PPPL Calculation Form

Calculation # NSTXU-CALC-132-08-02 Revision # 02 WP #, 1672
(ENG-032)

Purpose of Calculation: (Define why the calculation is being performed.)

To ensure that the TF crown and the TF insulation can take the out of plane torque load and safely deliver it to the center stack lid.

References (List any source of design information including computer program titles and revision levels.)
See the Section 5.1 of the Calculation.

Assumptions (Identify all assumptions made as part of this calculation.)

- 2.) the 9000 lbf equivalent force per TF conductor blade due to the OOP torque.
- 3.)The shear strength of the epoxy used to bond the CRES insert into the G10 crown piece is close to that of the CTD101K insulation at room temperature (103 MPa).

In Rev 2, the following assumption was resolved. The TF uses CTD 425 which has acceptable shear strength
“1.) the CTD101K insulation strength value at 100C, currently being measured by the manufacturer, is equal or higher than 25 Mpa for shear”

Calculation (Calculation is either documented here or attached)

Please see attached.

Conclusion (Specify whether or not the purpose of the calculation was accomplished.)

Stresses in the crown and the TF conductor are below the limits for Insulation, G-10 and copper. The normal stress in the epoxy filled fiberglass wrapped insulation is safely below 10 Mpa.
In Rev 2 , after the Hysol wet-layup, used in the crown, was found inadequate, the segmented crown was evaluated and found acceptable. See appendix B.

Drawing E-DC1738 Part 81 7/8" Inconel 718 Bolts (Upper crown bolts):
50,000 lb preload is needed. $T = .2 * F * D = .2 * 50000 * 7/8 = 8750$ in-lb = 729 ft-lbs

Drawing E-DC1738 Part 77 3/4" Inconel 718 Bolts (Lower crown bolts):
Put the same stress in the bolts, scale 50000 lbs by the areas
 $F = 50000 * .75^2 / .825^2 = 36734$ lbs
 $T = .2 * F * D = .2 * 36734 * 3/4 = 5510$ in-lb = 459 ft-lbs
Note: the drawing has these as 316 bolts. They should be 718

Cognizant Engineer's printed name, signature, and date

Jim Chrzanowski _____

I have reviewed this calculation and, to my professional satisfaction, it is properly performed and correct.

Checker's printed name, signature, and date

Ali Zolfaghari _____

2.1 Table of Contents

STRUCTURAL CALCULATION OF THE TF FLAG KEY

| | Section.Paragraph |
|--------------------------------------|-------------------|
| Title Page | 1.0 |
| Table Of Contents | 2.1 |
| Revision Status Table | 2.2 |
| Executive Summary | 3.0 |
| Digital Coil Protection System Input | 4.0 |
| Design Input, | 5.0 |
| References | 5.1 |
| Criteria | 5.2 |
| Drawings | 5.3 |
| Analysis Model | 6.0 |
| Model elements | 6.1 |
| Materials and Allowables | 7 |
| Bolt Capacities | 7.1 |
| Fatigue Data | |
| Results | 8.0 |

| | |
|--------------|--|
| Attachments | |
| Attachment A | Hysol Wet Layup Report (By Stephan Jurczynski) |
| Attachment B | Evaluation of the Segmented Crown |

2.2 Revision Status Table

| Rev 0 | Date | Initial Issue |
|-------|-----------|---|
| Rev 1 | 12/5/2011 | Radius in Figure 9.2.2-4 corrected to .35 meter from .7 m – loads re-calculated |
| Rev 2 | 8/1/2014 | Added Table of contents and Revision Status Table |
| Rev 2 | | Added Attachment A HySol Wet Lay-up Compression Tests |
| Rev 2 | | Added Attachment B Evaluation of the Segmented Crown |
| Rev 2 | | Added design drawings of the crown configuration prior to segmentation |
| Rev 2 | 9/9/2014 | Added Crown Bolting Requirements |

3.0 Executive Summary

The NSTX upgrade center stack TF conductors are designed to have a locking feature to engage the G-10 insulating crown and exchange the out of plane torque between the TF inner leg bundle and umbrella structure/vacuum vessel. The G-10 block and the TF conductors and insulation need to be able to withstand the forces in all working current scenarios. The TF conductors including epoxy insulation were modeled together with the G-10 block in cyclic symmetry models. Expected torques and forces were obtained from the global FEA model for the worst case out-of-plane twisting loads. The forces and

moments were exerted on the cyclic symmetry models. Initial designs of the locking mechanism involved teeth in the G-10 engaging the TF bundle and flags. Two different teeth models were studied. The first teeth model involved machining a pocket in the end of each conductor and a matching G-10 piece to engage the teeth. The second model used alternate short and tall flag pieces to engage the matched G10 crown. In both models the teeth in G-10 showed large shear stress which exceeded the G-10 inter-laminar shear limit. For this reason it was decided to design the locking mechanism using radial pins that engage the crown, the flags and the TF conductors. The calculations/simulations for this design showed lower stresses which were below the G-10 and the epoxy insulation stress limits. However the crown was first fabricated using a Hysol wet lay-up. It was tension wound with the reinforcing in the correct direction, but the glass density was poor.

In Rev 2 , after the Hysol wet-layup, planned for the crown, was found inadequate (See Attachment A) , the segmented crown was evaluated and found acceptable (See attachment B).

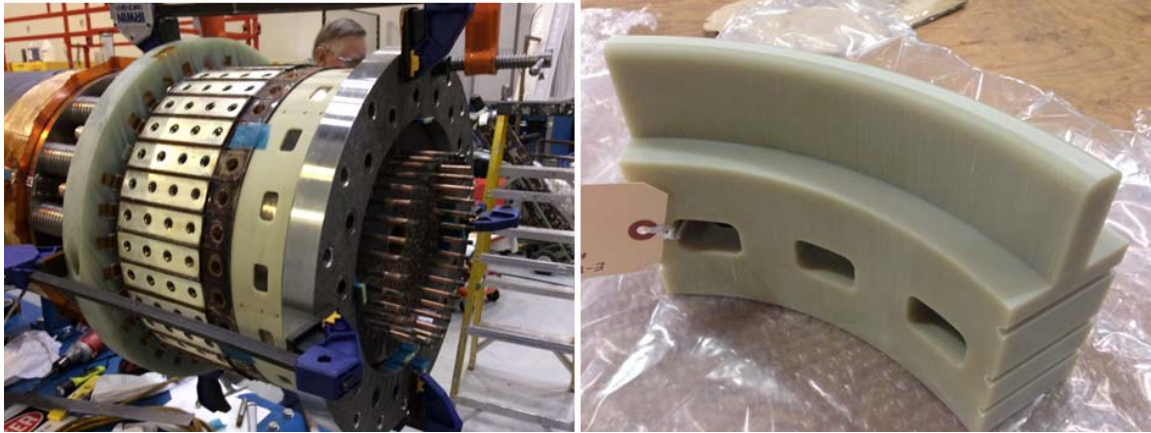

Figure 3.0-1 Machined Crown Segment

The wet wound layup was intended to align the strong reinforcement direction in the direction needed to take the torsional shear. The segmented crown pieces are machined from 6

Objective

In the NSTX upgrade, the inner and outer legs of the TF coils interact with the fields from the poloidal field coils and the OH resulting in torsional loads and out of plane forces which are transferred through several load paths to the vessel and other machine structures (Figure 1). These load paths include the lower and upper lids, umbrella structures, bellows etc. The current in the inner legs of the TF coils which interact strongly with the OH field cause torsional loads in the TF bundle that need to be supported against by transferring them via a stiff lid to the umbrella structure. Although the TF straps are going to share in the torque transfer but they are not designed to take the out of plane loads and the torque needs to be supported mainly through transfer by the lid. To do this and maintain electrical insulation between the TF and the vessel the TF bundle needs to transfer this torque to the inner hub of the lid using a locking feature employing the G10 insulator material as a crown.

4.0 DCPS Algorithm

The load used in the analysis was based on the maximum torsional shear load being transferred through the crown to the lid, for all the 96 scenarios. This number is actually 7400 lbs (Ref 1, section 8.19). This was rounded up to 9000 lbs for design. and to allow for the 10% headroom for PF currents and to allow some headroom for halo current loads. The torsional moment at the teeth will scale with the calculated torsional shear stress in the TF coil at the turn radius. For the 96 scenarios, this is 24 MPa. (ref 4). stresses should be scaled based on the TF torsional shear stress calculated for the DCPS

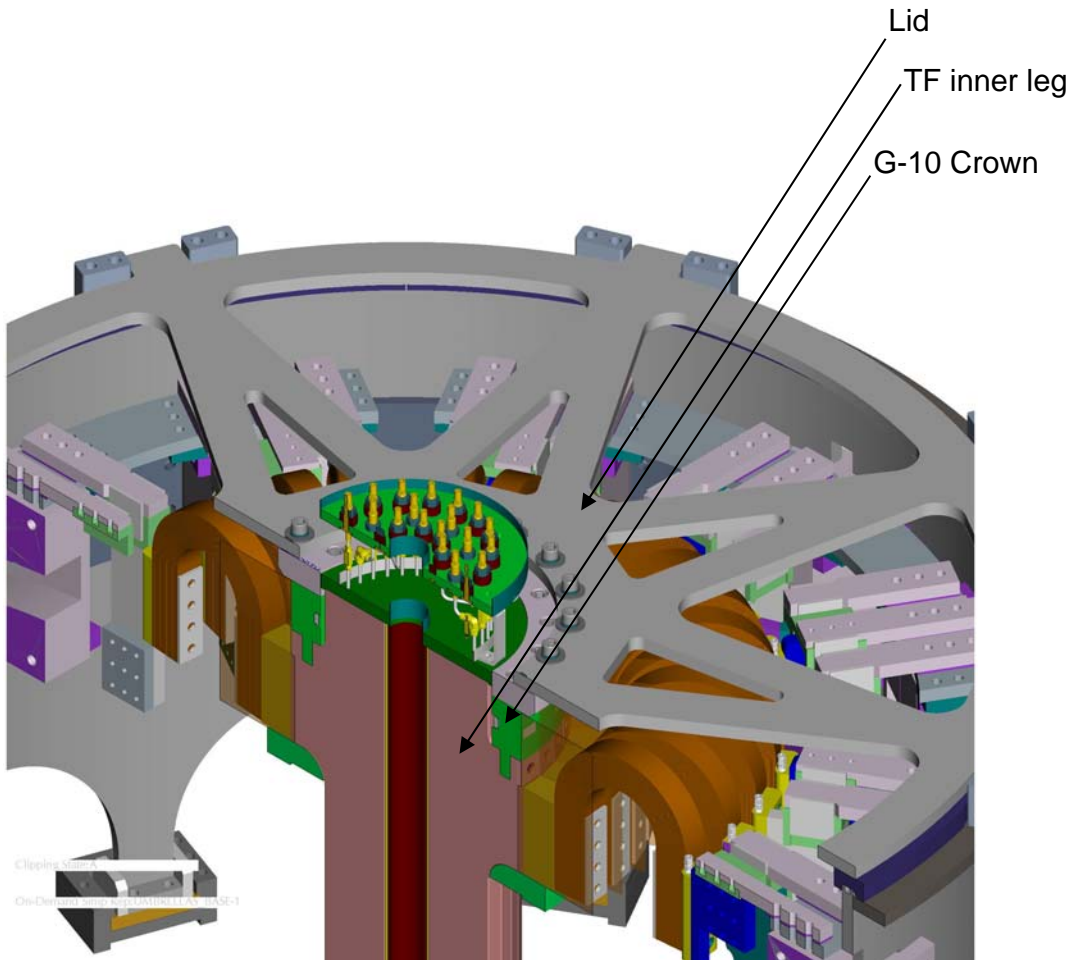

Figure 1

The mechanism for transferring the TF bundle torque was initially designed as radial teeth that locked the TF bundle to the G-10 crown. However as we'll show later in this calculation report, the stresses in the G-10 and insulation were shown to be high. For this reason a locking mechanism involving radial pins was designed (by Danny Mangra) to transfer the torque from the TF bundle to the crown and the lid. The calculation report here includes the analysis used to determine the stresses in the components of this design.

5.0 Design Input

5.1 References

- [1] NSTX-CALC-13-001-00 Rev 1 Global Model – Model Description, Mesh Generation, Results, Peter H. Titus December 2010
- [2] NSTX Structural Design Criteria Document, I. Zatz
- [3] NSTX Design Point June 2010 http://www.pppl.gov/~neumeyer/NSTX_CSU/Design_Point.html
- [4] NSTX-CALC-13-04-00 Rev 0 DCPS Inner leg torsional shear Stress, P.H. Titus, R. Woolley
- [5] Drawing E-DC1738 Centerstack Upgrade Centerstack Assembly, TF Inner Core and Centerstack Assembly, 11-26-2013
- [6] "Mechanical, Electrical and Thermal Characterization of G10CR and G11CR Glass Cloth/Epoxy Laminates Between Room Temperature and 4 deg. K", M.B. Kasen et al, National Bureau of Standards, Boulder Colorado.
- [7] INCO/Specialty Metals "Blue Book" 718 mechanical data

5.2 Criteria

NSTX Structural Design Criteria Document [2]

5.3 Drawings

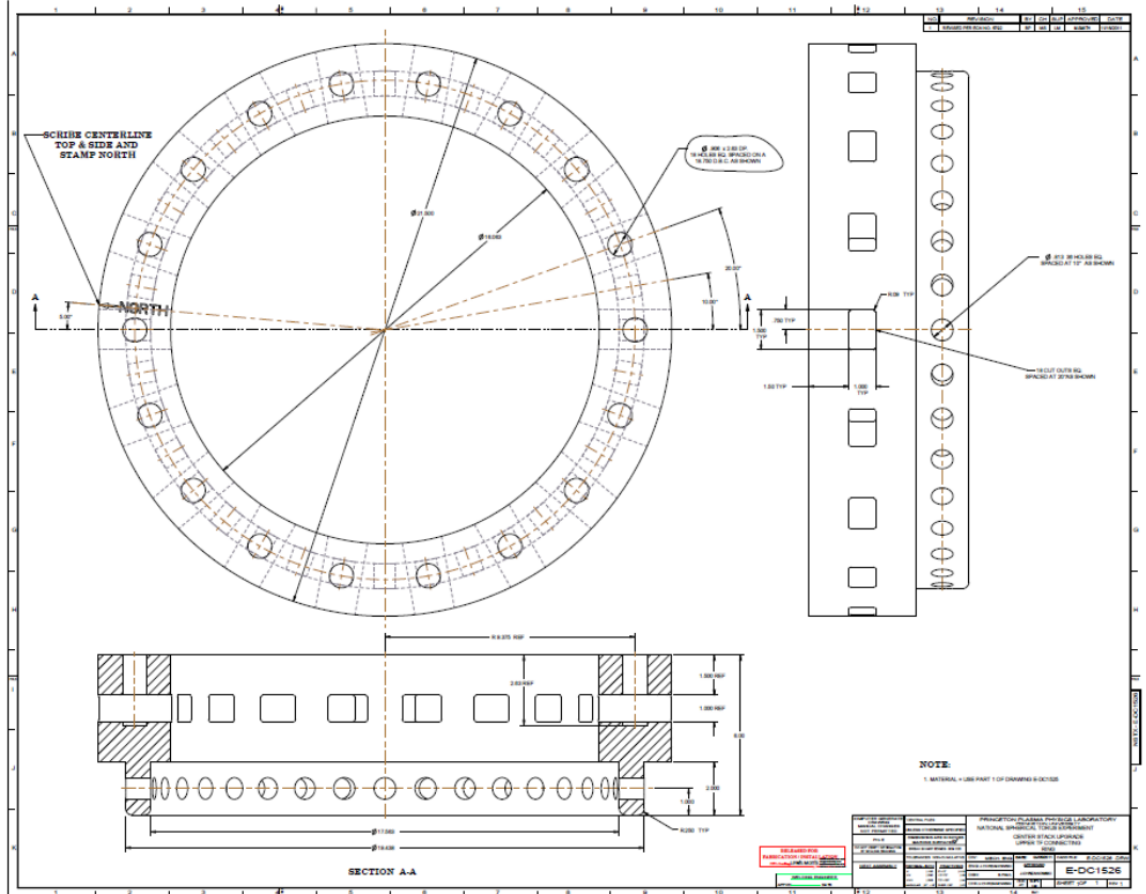

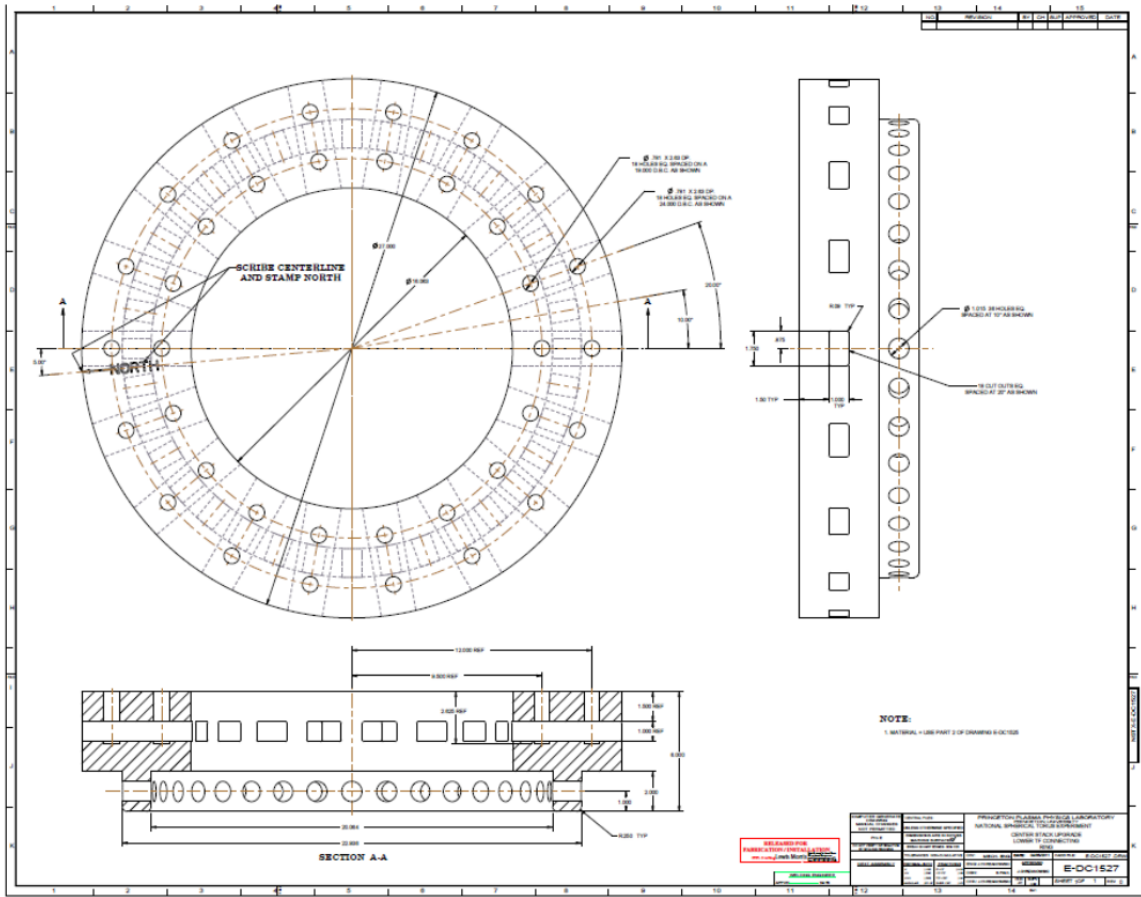

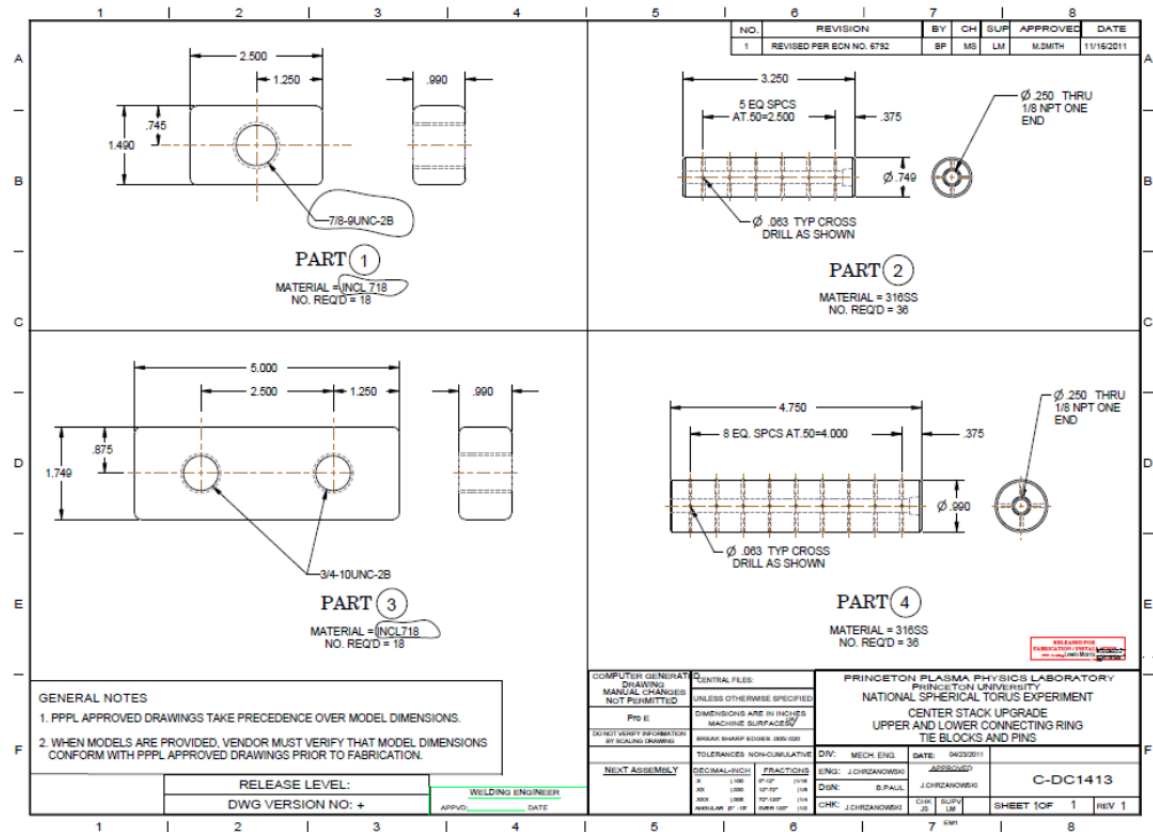

6.0 Calculation and modeling techniques:

Ansys software was used to analyze the structure. Due to the cyclic symmetry of the geometry analysis was performed on 1/18 of the problem geometry (or one TF blade two half blades, Figure 2). Ansys was instructed to match mesh and impose symmetry conditions on the symmetry planes. The geometry also included the TF conductor epoxy insulation bonded to the conductor. The design of the crown included stainless steel inserts to be used as nuts for bolting the lid to the upper portion of the crown. The actual fabrication and assembly of the structure involves using glass fiber and epoxy during or after the wet wrap process to secure these inserts. For this reason we have used a “bonded” contact type for the analysis of the contact area involving the insert and the G-10 crown.

The amount of torque and moments expected to be exerted on the locking assembly was obtained from the global FEA model maintained by P. Titus (Ref 1, Section 8.19). The worst case out of plane twist load from the global model corresponded to 360,000 N.m of torque on the crown to TF bundle interface which results in approximately 9000 lbs force per blade/flag. This comes to 18,000 lbs (80200 N) for the 1/18 model and was exerted on top of the plate/lid (Figure 3). The moment load on the G-10 crown resulting from the thermal expansion of the TF inner legs was estimated to be 620 N.m. This was done by putting a unit torque on the G-10 piece only and calculating the resulting stress peaks and distribution. Then comparing these peaks with the peaks of the stress in the G-10 from

the Spoke/Lid calculation (NSTX-CALC-12-08-00). This torque was put on the top surface of the G-10 crown piece in the model analyzed (Figure 3). The model was held fixed on the bottom and a locked pretension of 50,000 lbs (2.22e5 N) is applied to the bolt. Friction ratio of 0.35 was imposed on the plate/G-10 Crown interface.

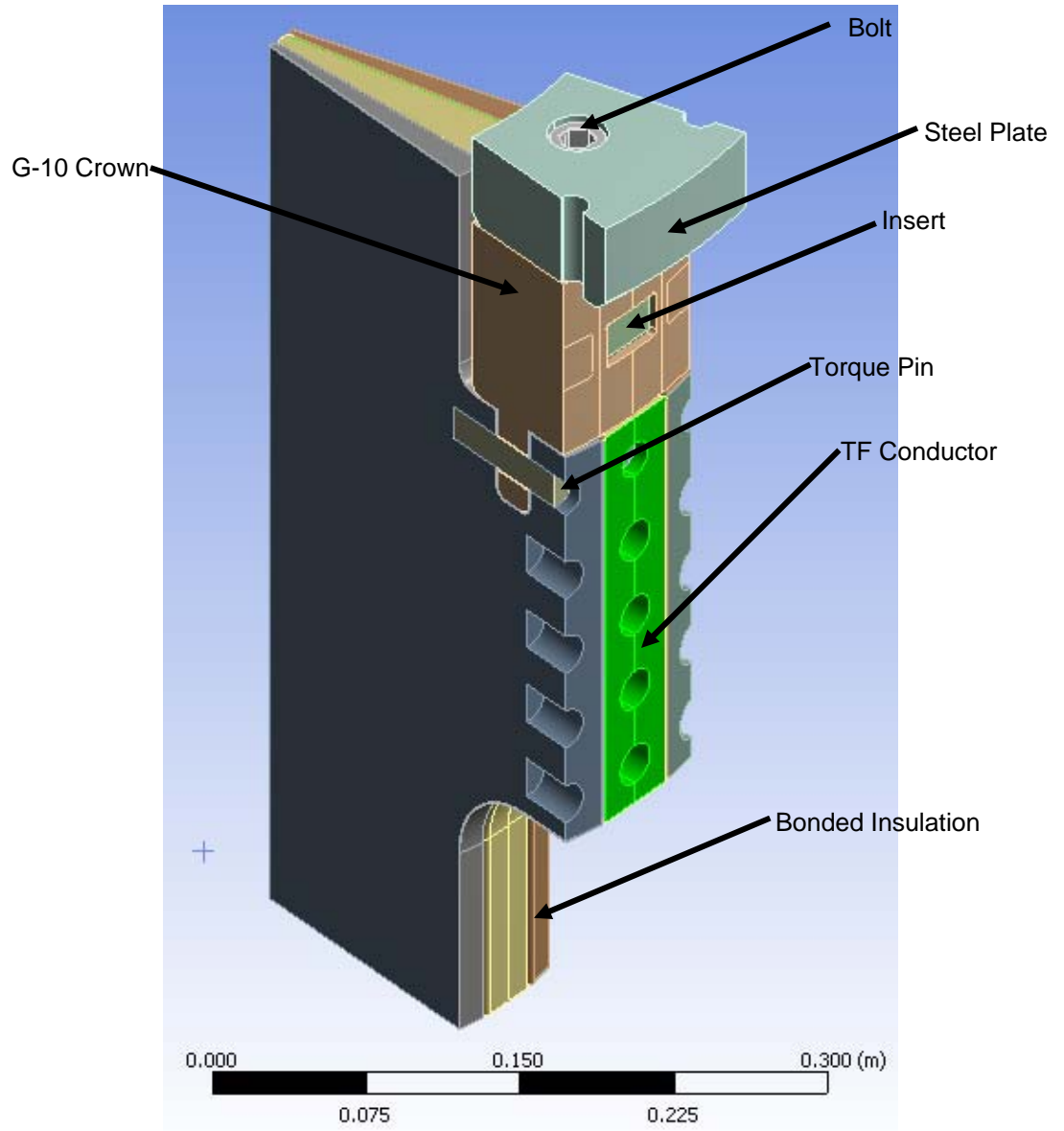

Figure 2

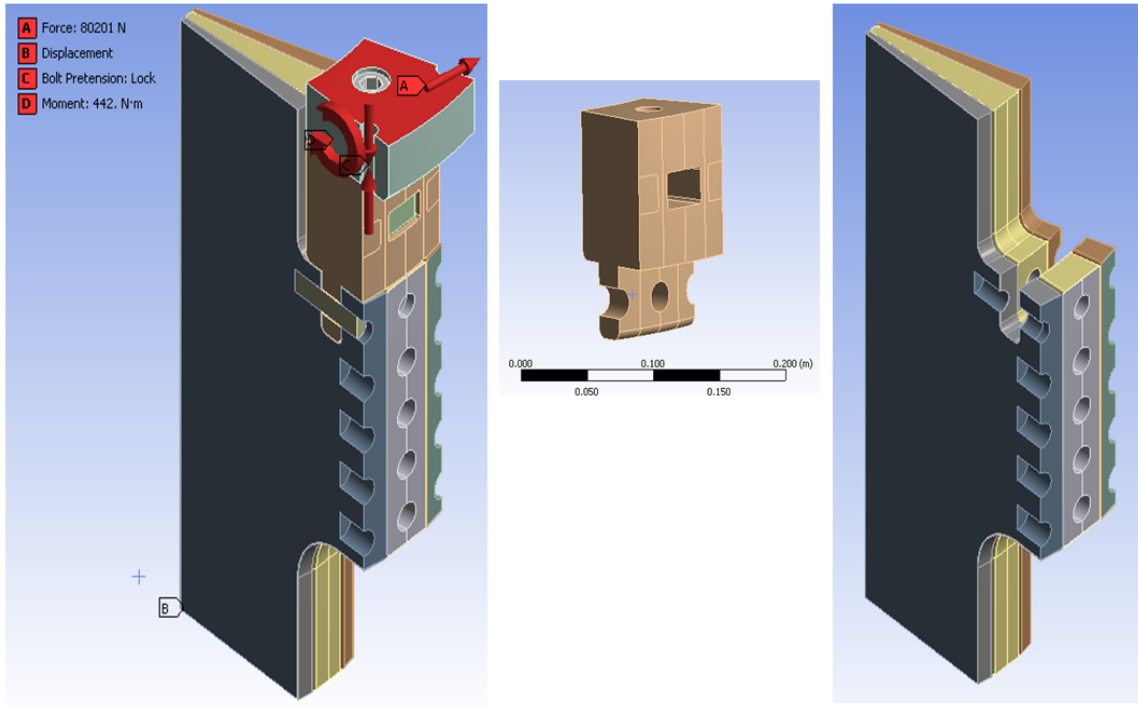

Figure 3

7.0 Materials and Allowables

7

The material used for the crowns is G-10 bought with the proper G-10 specifications.

| | @4 | @77 | @292 degK |
|-------------------------------|-----|-----|------------------------|
| Comp.Strength Normal to Fiber | | | |
| G-10CR | 749 | 693 | 420 Mpa Ref[6] |
| G-11CR | 776 | 799 | 461 MPa Ref[6] |
| Tensile Strength (Warp) | | | |
| G-10CR | 862 | 825 | 415 MPa Ref[6] |
| G-11CR | 872 | 827 | 469 MPa Ref[6] |
| Tensile Strength (Fill) | | | |
| G-10CR | 496 | 459 | 257 MPa (37ksi) Ref[6] |
| G-11CR | 553 | 580 | 329 MPa Ref[6] |

High Strength Inconel 718 Bolts are used for the crown bolting.

718 Typical Mechanical Properties At Room Temperature:

| Ultimate Tensile Strength | Yield Strength (0.2 % offset) | Elongation in 50 mm (2") | Elastic Modulus (Tension) |
|---------------------------|-------------------------------|--------------------------|---------------------------|
| MPa ksi | MPa ksi % | | GPa 106 psi |
| 1240 180 | 1036 150 | | 12 211 30.6 |

This data is from an internet source and is consistent with the INCO/Specialty Metals data [7]

1/3 Ult=60ksi 2/3 yield=100 ksi Sm=60ksi, Bending Allowable = 90 ksi

The allowed shear stress is $.6 * sm = 36$ ksi

- Mike Kalish at PPPL reports that the physicals of the NSTX TF flag Inconel 718 stud is 210 ksi (1448MPa) and the yield strength is 185 ksi (1275MPa) at RT

8.0 Results:

The results of the FEA analysis for this design are shown in Figure 4-7. Figure 4 is a contour plot of equivalent stress on the center conductor /blade in the model. Figure 5 is the equivalent stress in the G-10 crown piece. As can be seen from these plots the stresses are below the manageable limits for copper, epoxy, and G-10. The shear stress in the insulation is shown in Figure 6a. We are not concerned with the higher values of the shear seen in the bottom were the model is being kept fixed (See reference 1). Figure 6b is an expanded view of Figure 6a over the area of interest which shows the insulation shear stress is below the (Cyanate Ester) fatigue-limited bond strength which is 22 MPa. Figure 7 is the normal stress in the epoxy filled fiberglass wrapped insulation. As can be seen the normal stress in the insulation is below 10 MPa. However it was pointed out to us that the bolt pretension of 50,000 lbs is excessive on ¾ inch diameter bolts and that can be seen on figure 8 showing the stress in the bolt.

Reduction on the bolt pretension results in reduced friction and slippage between the plate-Crown interface. One question that was asked was if the bolts can take the load in shear acting as shear pins. To analyze this scenario we reduced the pretension to 15,000 lbs which according to the simple calculation below will provide stress at the limit of standard stainless steel:

$$\begin{aligned}
 \text{BoltDiam} &:= 0.75 \cdot \text{in} \\
 \frac{\text{BoltDiam}}{1000} &= 9.525 \times 10^{-3} \text{ m} \\
 \text{BoltArea} &:= \frac{3.14 \text{BoltDiam}^2}{4} \\
 \text{BoltArea} &= 0.442 \cdot \text{in}^2 \\
 \text{stresslimit} &:= 34 \text{ ksi} \qquad \text{stresslimit} = 2.344 \times 10^8 \text{ Pa} \\
 \text{AllowdPreLd} &:= \text{stresslimit} \cdot \text{BoltArea} \\
 \text{AllowdPreLd} &= 1.501 \times 10^4 \cdot \text{lbf}
 \end{aligned}$$

The analysis shows the resulting slippage at the interface as seen in figure 9. The stress on the bolts resulting from the bending and shear also exceeds the limit as shown in figure 10. As a result we have recommended that the design uses 7/8 Inconel 718 bolts at 150 ksi yield. The preload can then be 50,000 lbs ensuring enough friction with a friction ratio=0.35. To ensure 0.35 friction ratio we will need a measured friction ratio of 0.5 (0.15 larger according to GRD). This is achievable with diamond dusted friction enhanced shim material. Also we recommend the use of Bellville washers to keep pretension in the bolt due to possible G10 creep.

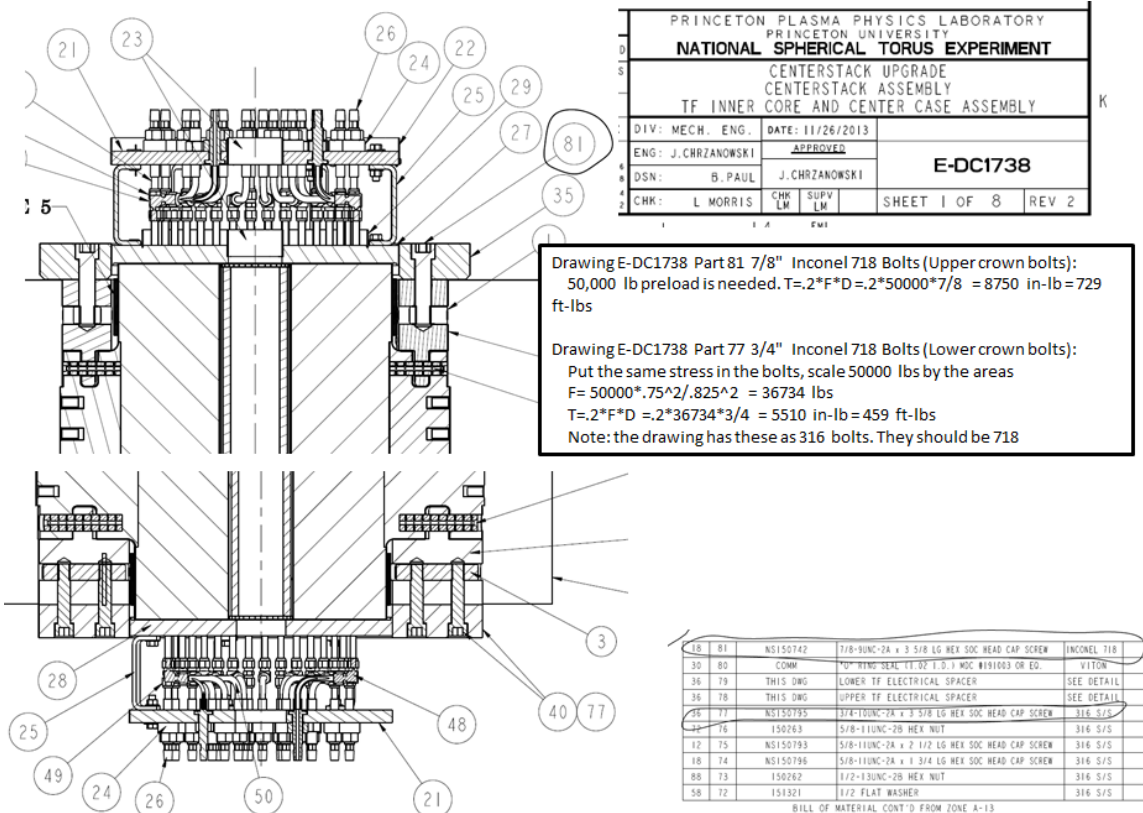

Figure 3a Crown Bolting Requirements

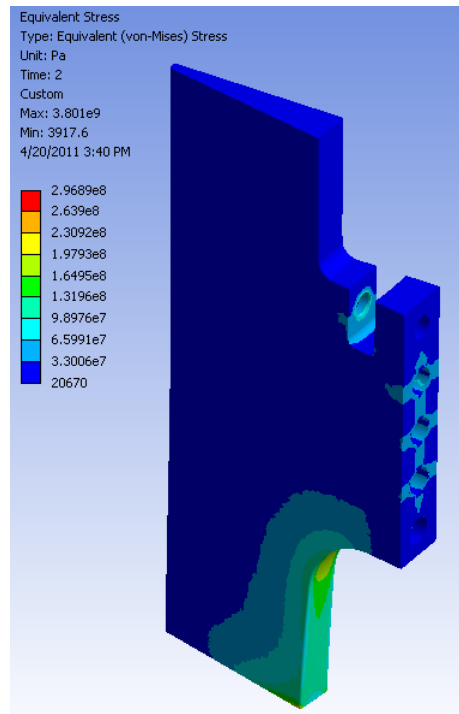

Figure 4

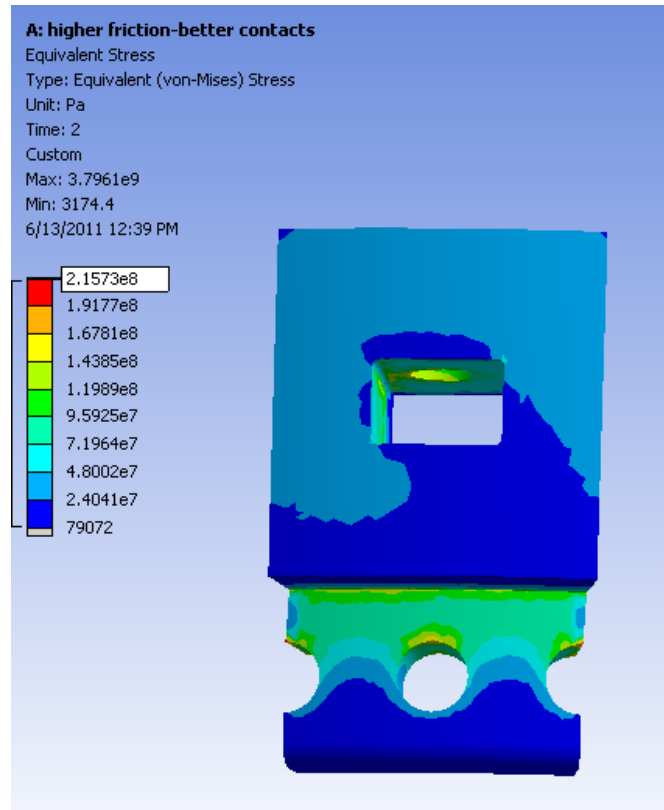

Figure 5

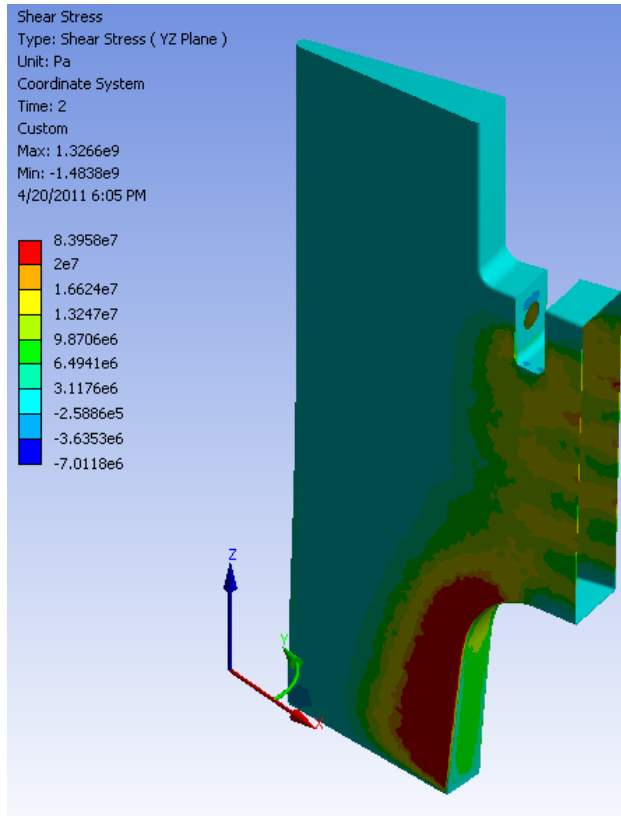

Figure 6a

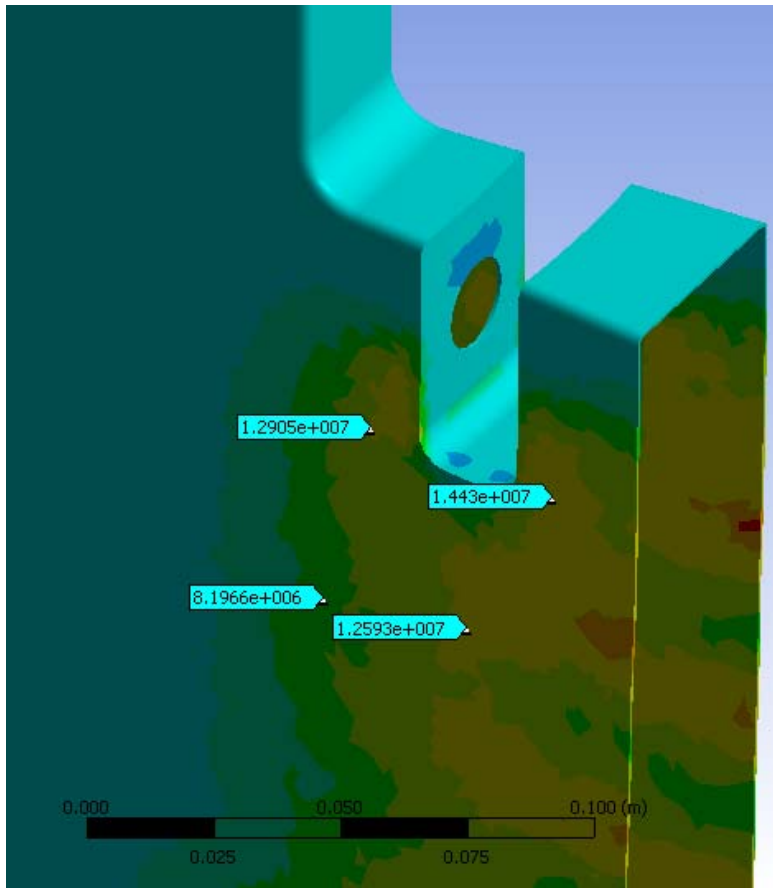

Figure 6b

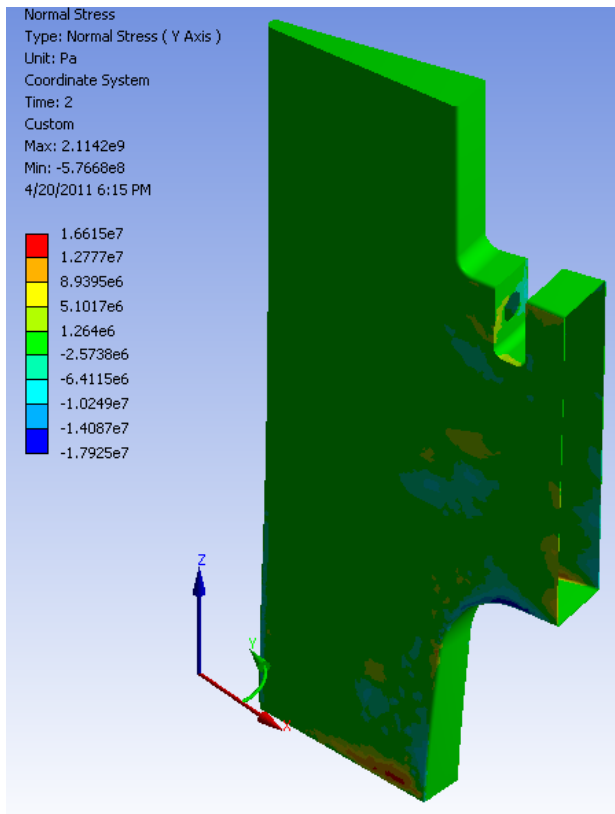

Figure 7

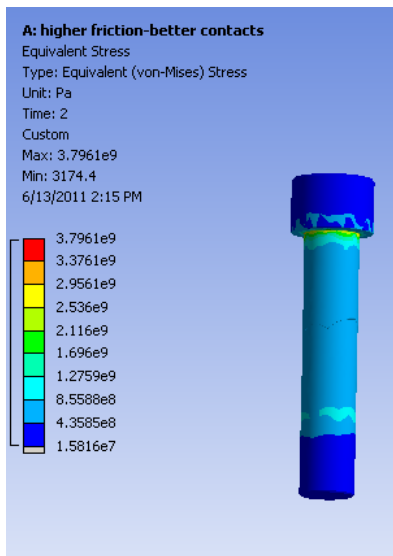

Figure 8

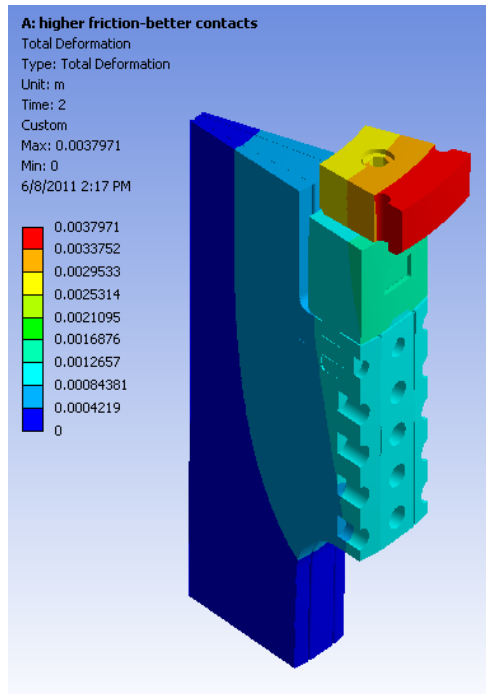

Figure 9

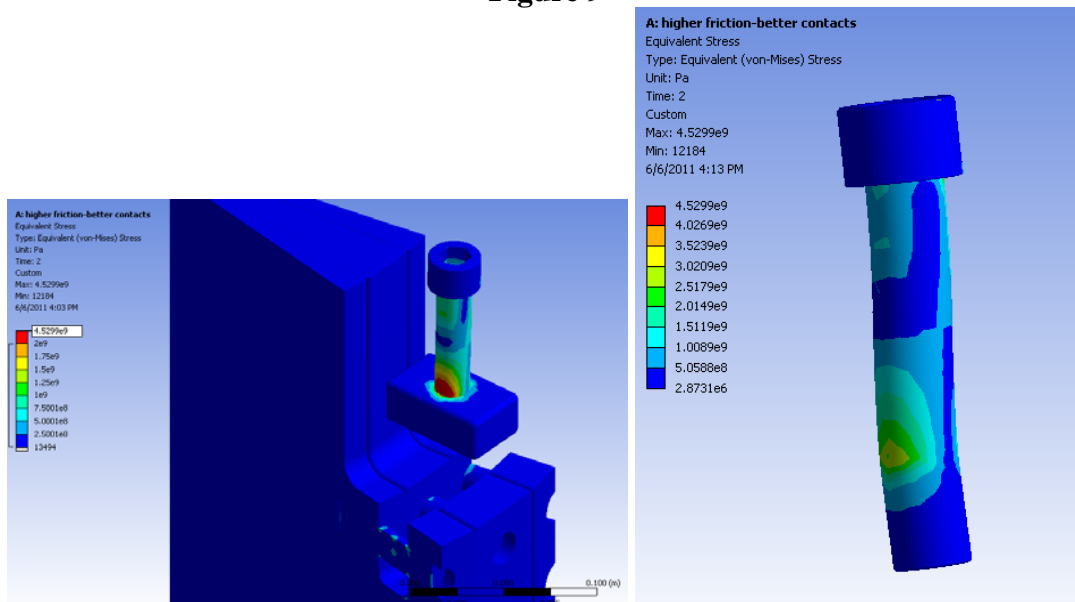

Figure 10

Analysis with Upward Halo current loads on lower G-10 crown and G-10 ring:

The lower G-10 crown also sees the addition upward loads resulting from the Halo currents. To analyze the effect of this load we used the upper crown geometry of Figure 3

while noting that the tongue in the lower crown is 50% thicker. We added a load of 12000 lb (53270 N) to the top of the plate as can be seen in Figure 11.

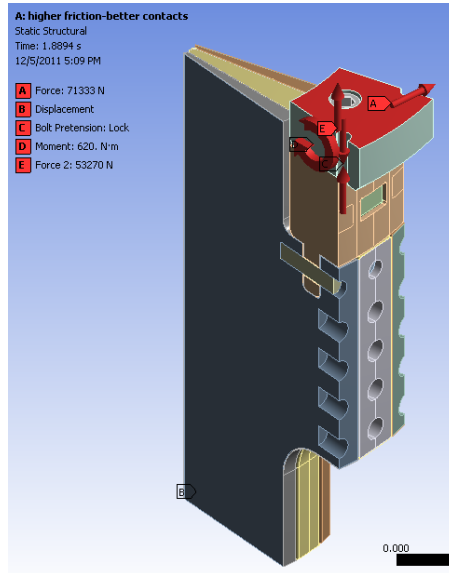

Figure 11

The resulting stress in the G-10 crown from this load and all other loads is shown in Figure 12. Comparison of the stress in Figures 12 and 5 shows a modest increase in the equivalent stress in the G-10. This combined with the fact that the bottom G-10 crown tongue is 50% thicker (i.e. approx 1.5 inches thick) gives us confidence that the G-10 crown can withstand the upward halo current loads.

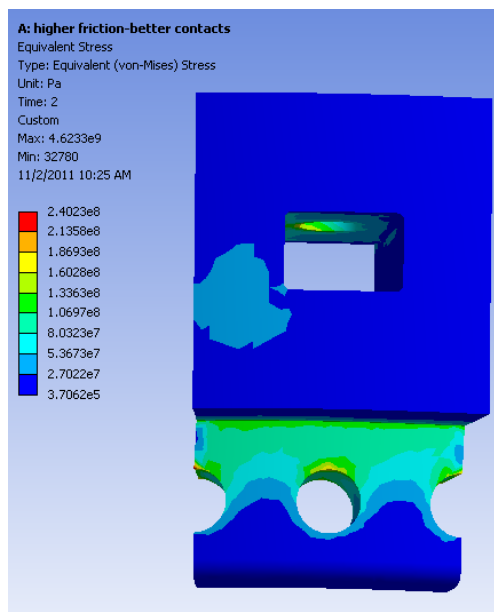

Figure 12

The G-10 ring on top of the TF flags in the bottom of the machine is attached using countersunk bolts and thread inserts to the TF flags. The centerstack skirt and the OH bottom cage flange are in turn attached to the G-10 using bolts and thread inserts into the G-10 ring at a more radially-outward bolt pattern. Figure 13 shows this interface.

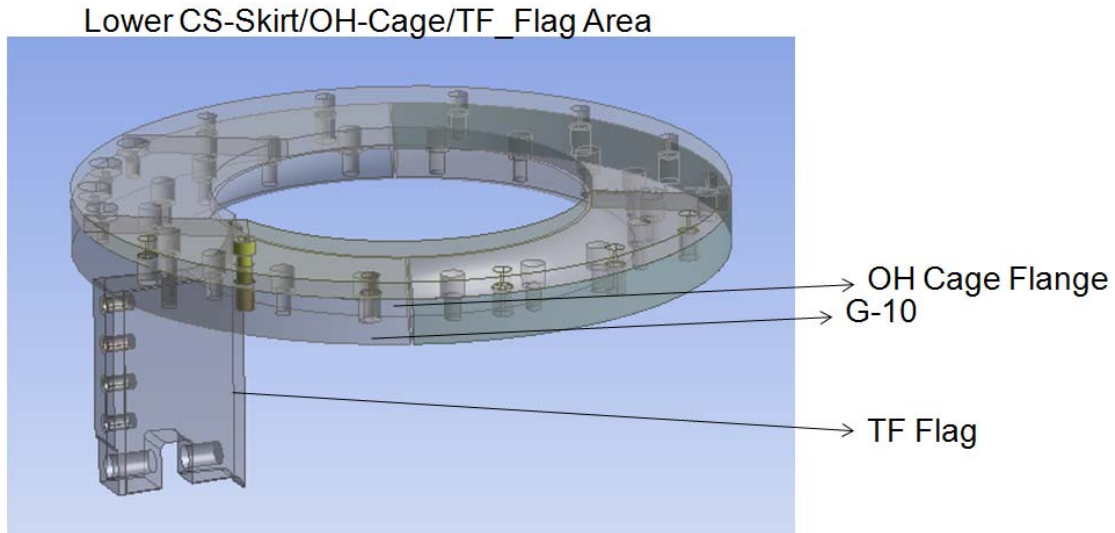

Figure 13

The concern has been the lateral loads on the centerstack that would transfer through the CS skirt to the bolts that connect that to the G-10 ring. We analyzed this by applying 12000 lb to one bolt while keeping fixed the area under the radially inward bolt (i.e. the bolt that attaches the G-10 ring to the TF flags) as can be seen in Figure 14.

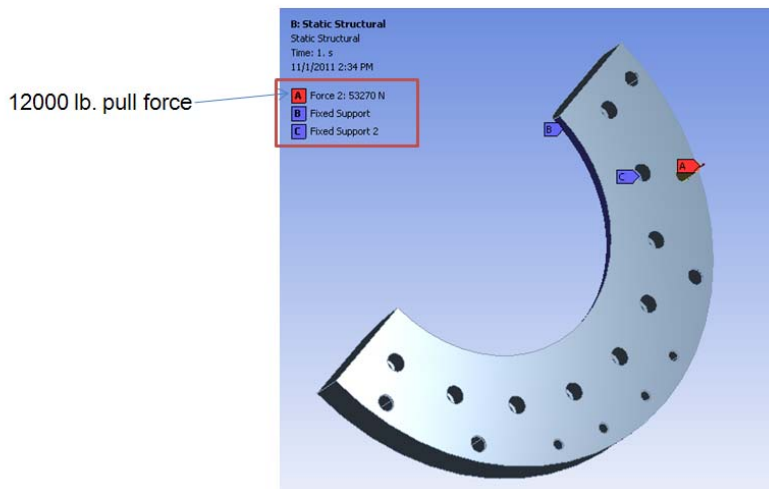

Figure 14

The resulting stresses shown in Figure 15 and 16 shows that the stress intensity and shear stress in the G-10 especially around the thread insert are below the allowable 150 MPa for stress intensity and 75 MPa for shear stress.

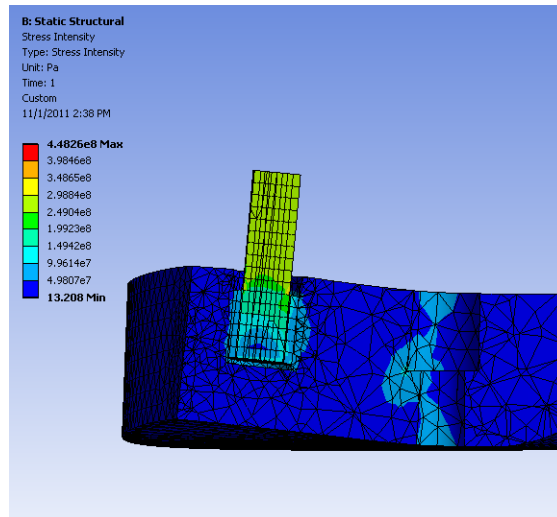

Figure 15

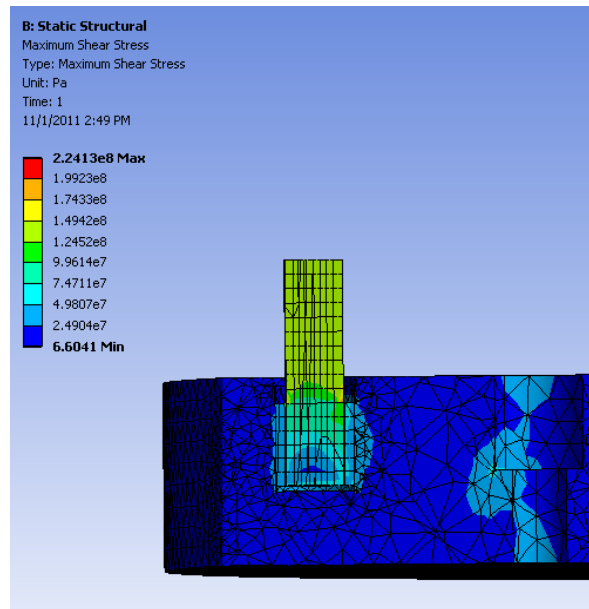

Figure 16

Initial (Teeth) Designs:

The initial designs of the torque transfer mechanism included sets of teeth arranged in the toroidal direction to engage the G-10 insulating crown and exchange the out of plane torque between the TF inner leg bundle and umbrella structure/vacuum vessel. The teeth

in the G-10 block, the TF conductors, and the insulation need to be able to withstand the loads in all working current scenarios. To evaluate these designs, TF conductors including epoxy insulation were modeled together with the G-10 block in 1/18 and 1/36 cyclic symmetry models. Expected torques and forces were obtained from the global FEA model for the worst case out-of-plane twisting loads. The forces were exerted on the cyclic symmetry models. Figure 8 shows sections of the two different teeth models studied. The first teeth model used alternate short and tall flag pieces to engage the G-10. The second model involved machining a pocket in the end of each conductor and a matching G-10 piece to engage the teeth.

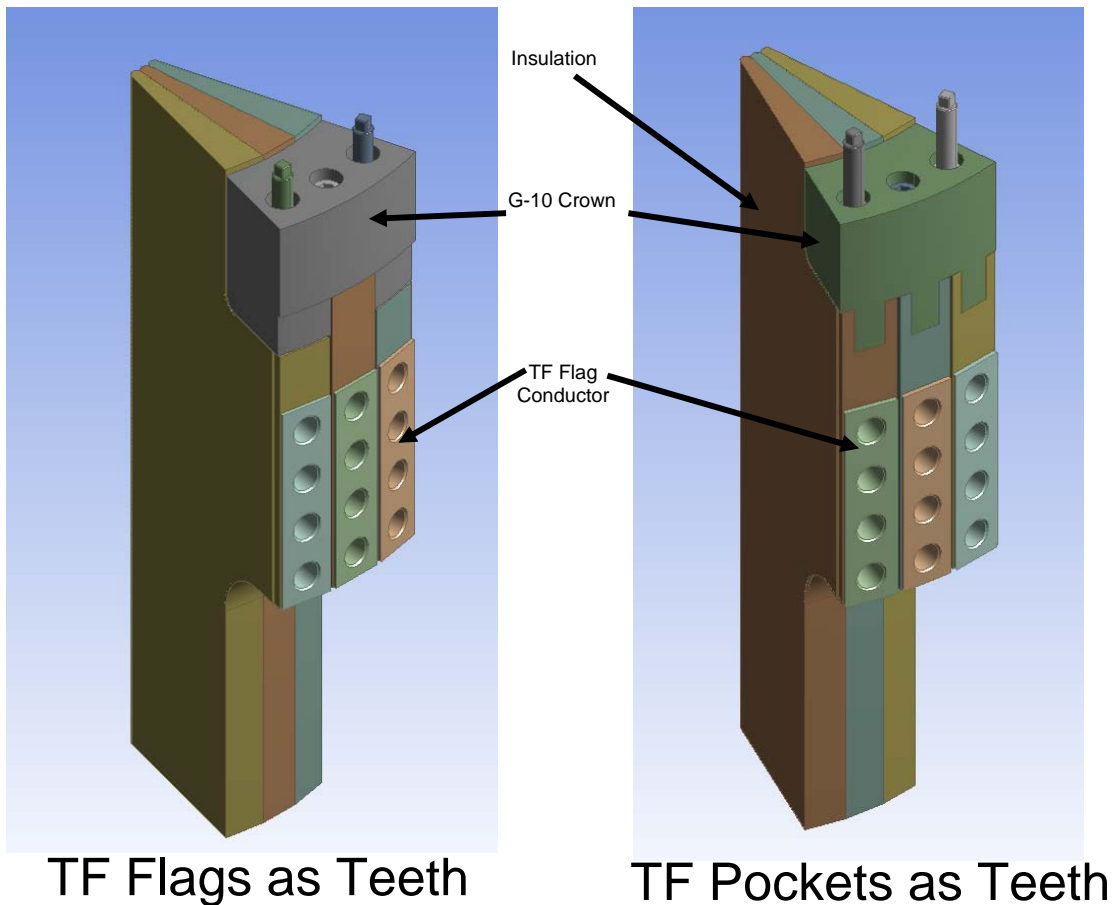

Figure 8

Cyclic symmetry FEA analyses similar to the one described above were performed for these two design. Figure 9 is the contour plot of equivalent stress in the G-10 crown. The teeth in G-10 showed large shear stress which exceeded the G-10 inter-laminar shear limit. In order for these designs to work it would be necessary to put a secondary G-10 crown ring to increase the teeth surface area in the radial direction in the upper and lower

centerstack TF keys. Alternatively, a new insulating 3D orthogonal woven composite material with substantially higher lateral shear strength can be used for the crown.

Due to the nature of the first design, the bonded epoxy insulation between the TF conductors is heavily stressed. Figure 10 shows the normal stress in the insulation in the toroidal direction. The stress in the insulation exceeds the 10MPa limit causing localized delamination (albeit benign) of the TF conductor insulation.

Figure 11 is a contour plot of the shear stress at the epoxy copper bond in both designs.

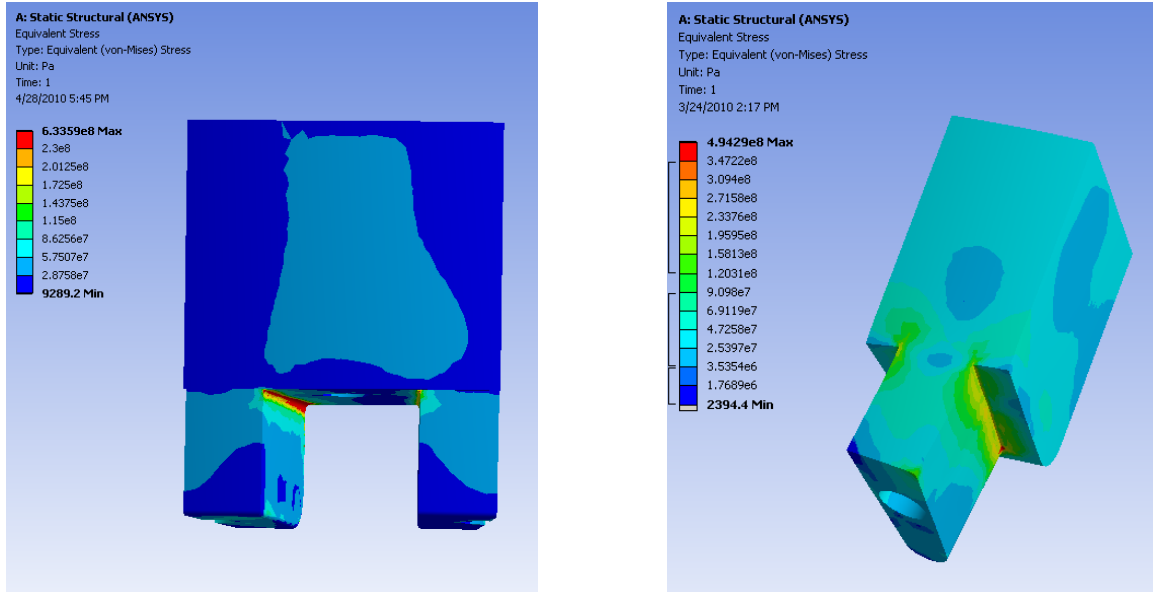

G10 teeth engaging TF Flag

G10 tooth engaging TF pocket

Figure 9

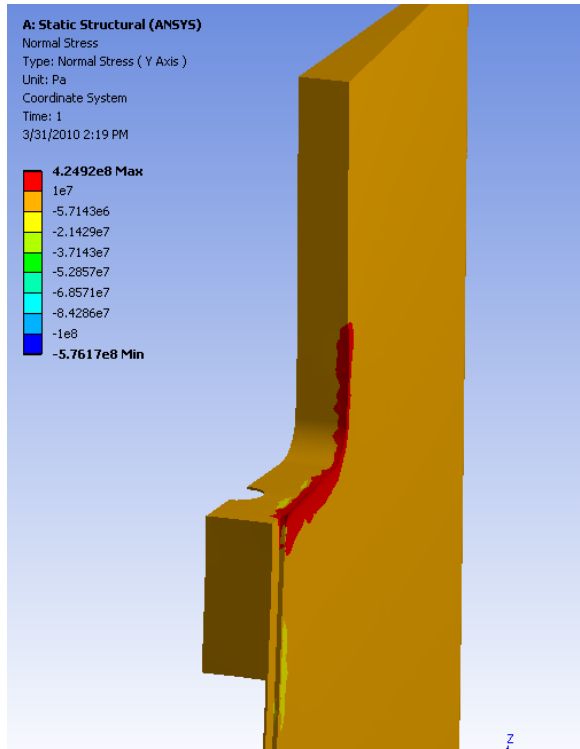

Figure 10

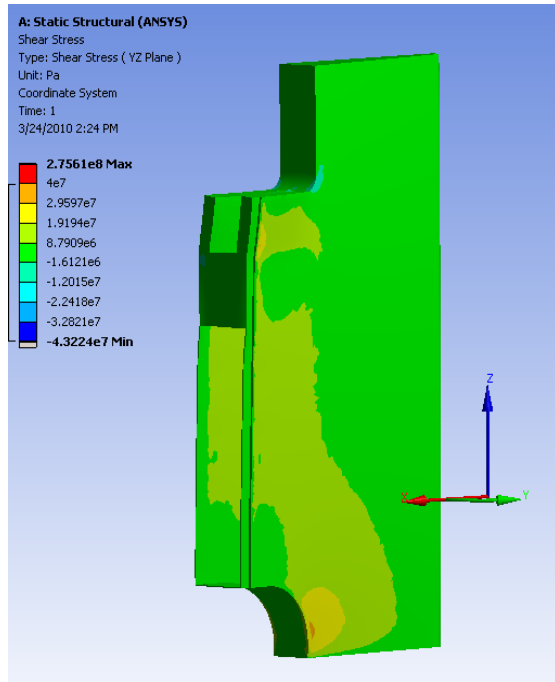
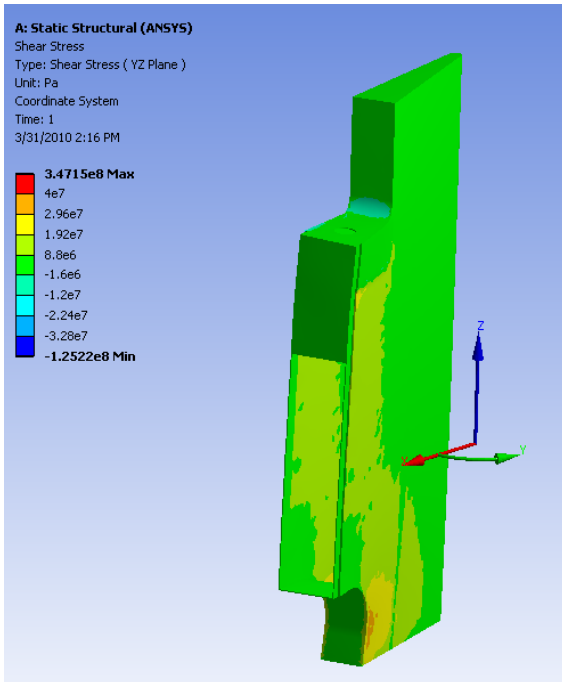

Figure 11

Attachment A
Hysol Wet Lay-up

Compression Test (By Stephan Jurczynski)

2014-02-27

WR#20141474

MTL#398

Testing comprised of 5 samples cut from a TF Connecting Ring Wet Lay-up ("Crown") exposing samples with the fibers running axially in the longitudinal direction.

| Sample: | Rupture Load | Rupture Stress |
|------------------------------|--------------|----------------|
| #1: 0.440" x 0.440" x 0.760" | -2250lbs | -11.6ksi |
| #2: 0.440" x 0.440" x 0.755" | -3200lbs | -16.5ksi |
| #3: 0.440" x 0.440" x 0.755" | -3020lbs | -15.6ksi |
| #4: 0.440" x 0.440" x 0.752" | -2690lbs | -13.9ksi |
| #5: 0.440" x 0.440" x 0.755" | -2780lbs | -14.3ksi |

Cross sectional area used for test calculation: 0.440" x 0.440" = 0.1936sqin

Load and strain data readings were taken directly in real time using a MTS 10kip servo-hydraulic tensile and compression test machine.

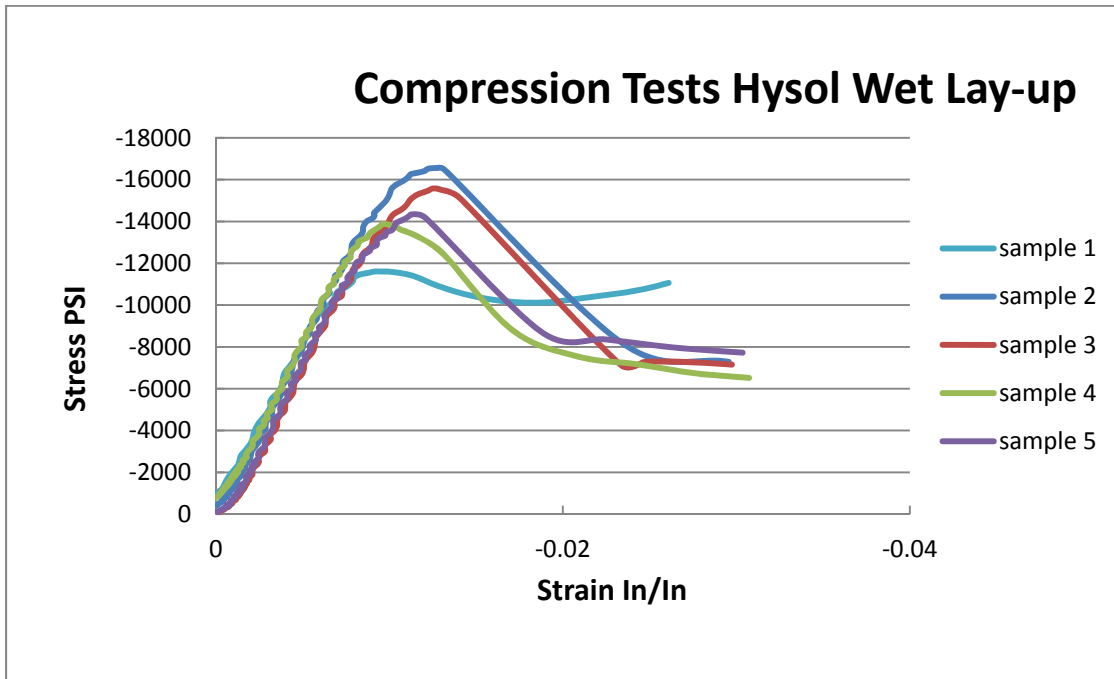

Attachment B Evaluation of the Segmented Crown

The wet layup crown proved in-adequate to take the design loads and an alternative needed to be found.

Insulating Material Strengths

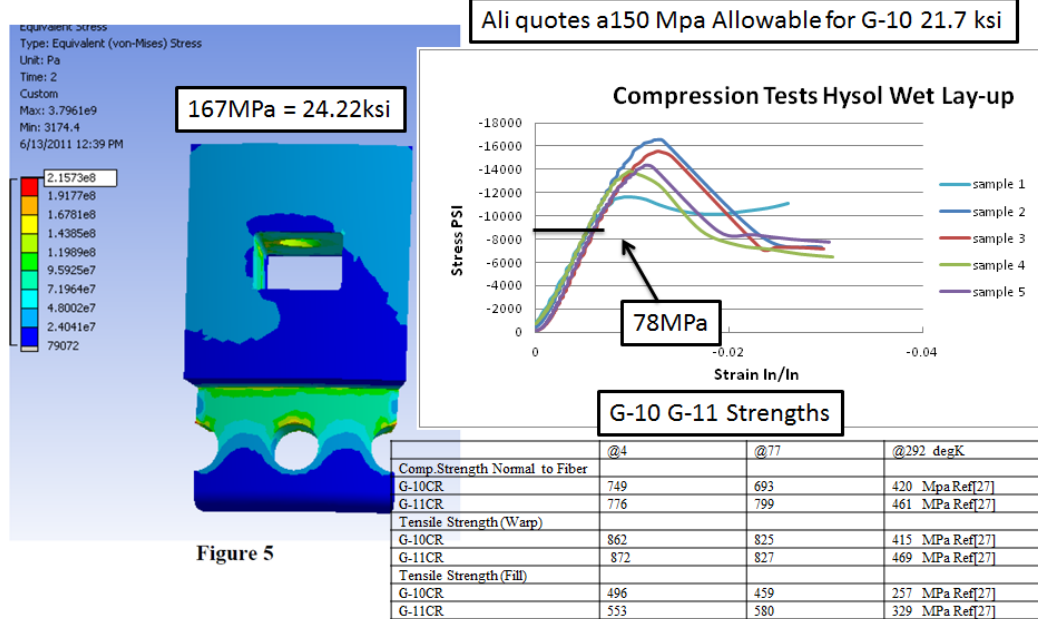

Attachment B Figure 1 Wet Layup Strength Much Lower than G-10

In the time available, another attempt at winding a collar was not feasible. Instead a segmented crown was investigated. This could be made from high pressure laminate with a high glass content that met the structural specifications of G-10. To have the strength in the appropriate directions to take the torsional shear and vertical compression from the bolt preload, the reinforcing glass directions were chosen the toroidal original wrapped direction.

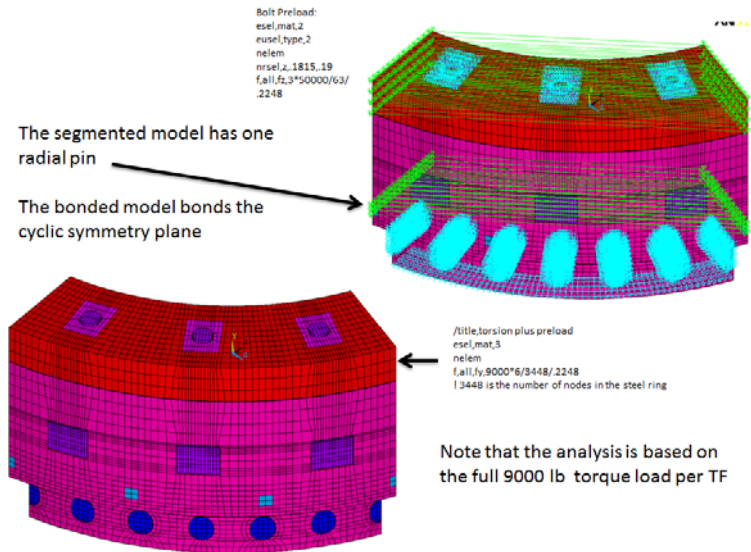

Attachment B Figure 2

Ali's model is slip fit to the TF Blade groove. My model is similarly connected through the pins.

Use my (Titus) model to estimate the effect of segmentation, and retain Ali's analysis as the qualification basis

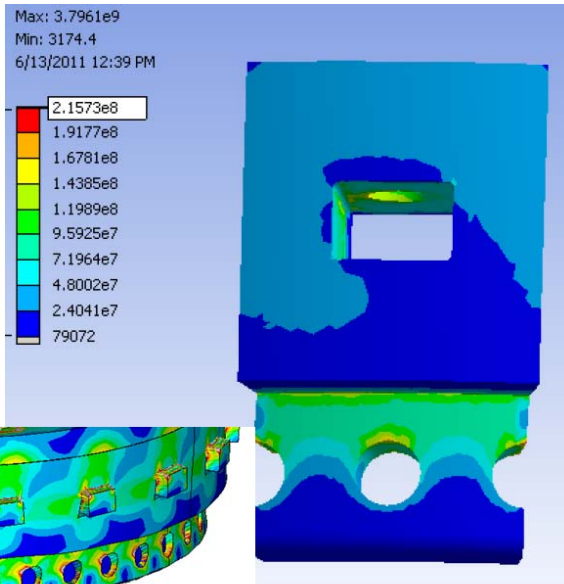

Ali's model

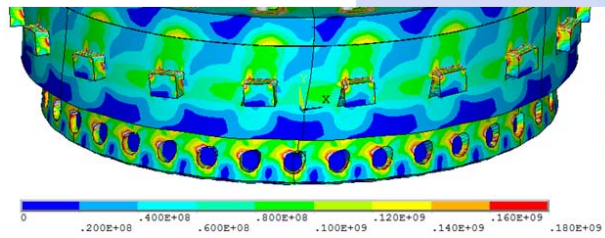

Attachment B Figure 3

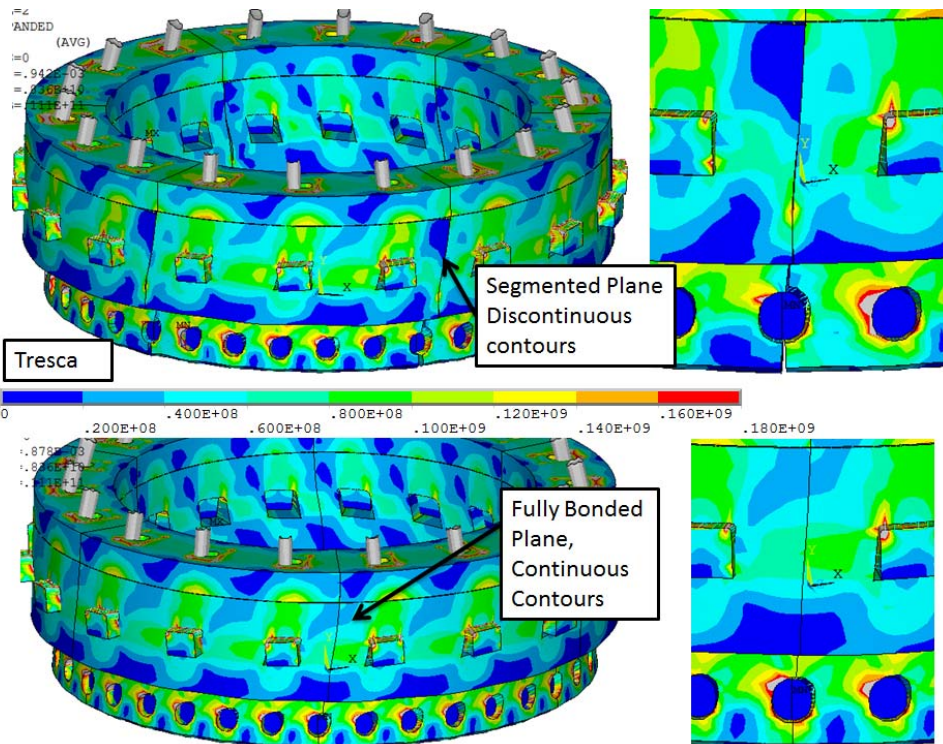

Attachment B Figure 4

In Figure 4, Note that the pin stress contours are not changed substantially with the segmentation. Displacements at the parting plane can be reduced by bonding and inserting radial G-10 pins as shown in figure 4.

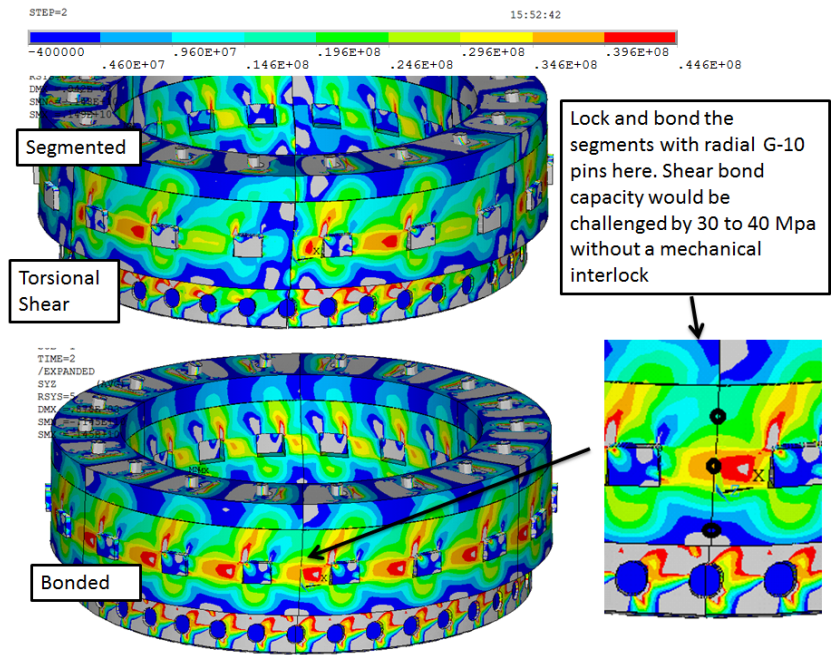

Attachment B Figure 5

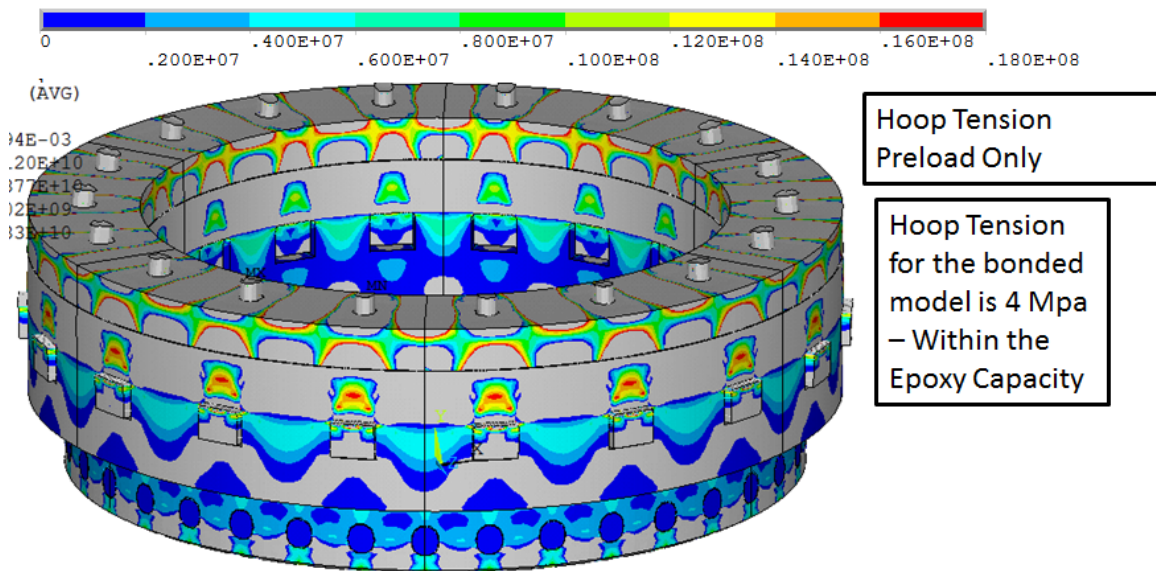

Attachment B Figure 6

Bolt preload is large. Each bolt is preloaded to 50,000 lbs. The array of preloaded bolts will produce a poisson expansion from the compressive stress. This will be non-uniform depending on the compressive stress distribution. Hoop tension may develop in regions of the crown. This is shown in figure 5, but it is only 4 MPa and is within the expected bond strength of the Hysol.

