



NSTX-U

Redesigned Vacuum Vessel Support Bracket

NSTXU-CALC-12-10-00

Rev 0

March 2012

Prepared By:

Peter Rogoff, PPPL, MED Engineering

Reviewed By:

Irv Zatz, PPPL, MED Engineering

Reviewed By:

Peter H. Titus, PPPL, MED Branch Head

PPPL Calculation Form

Purpose of Calculation: (Define why the calculation is being performed.)

The NSTX Vacuum Vessel (VV) main support structure consists of a specially designed “Chair” which is welded at four locations ninety degrees apart along the surface of the Vessel. However, the clevis assemblies are required at thirty degree intervals to provide connectivity between the lower TF coil ring/clamp assembly and the VV. This mechanism provides better structural support for total NSTX-U device. The original device (the NSTX) had a completely different support structure which permitted a symmetric “Chair” design. Because of the introduction of the heavy link member (see, NSTX-U-CALC-132-12-00), the existing structure had to be redesigned eliminating part of the assembly. This new geometry and the FEA model simulation are provided in the enclosed power point presentation. Therefore, a complete set of analyses to check the integrity of the redesign were required for various new loads and VV temperature conditions.

References (List any source of design information including computer program titles and revision levels.)

A complete set of FEA simulation runs were performed utilizing the “FEA 2010.1r.2, NASTRAN code”. Applied forces and boundary conditions were extracted from various ANSYS code Global Models simulations. Results are presented in the best possible graphics format clearly marking maximum stress and/or strain values and locations.

Assumptions (Identify all assumptions made as part of this calculation.)

For this analysis the following assumptions are important: The ninety degree VV sector is simulated to provide the complete symmetry representation in the vicinity of the chair/support structure. This provides sufficient simulation for the boundary conditions to permit the critical location stress/strain values predictions. NASTRAN MPC conditions are utilized to simulate the VV symmetry condition. Loads are applied as pressure on the vertical open VV surface as demonstrated in the power point slides. The vertical support beam is fully fixed at the location where angled brackets connect it to the test cell floor. This is expressed with the NASTRAN SPCs application set to zero for three principal coordinates. (Note: since the used solid elements require only translational (X, Y, Z) degrees of freedom). The assumption is that at this location, the complete support structure remains in a steady state condition because of the angled floor brackets.

Calculation (Calculation is either documented here or attached)

All the existing calculations are provided and explained by the following Power Point file:

[Vessel-Support-Chair.ppt](#)

This presentation describes the complete set of the NASTRAN simulation of the VV Chair- Support structure. This file presents simulations inputs as well as the outputs for the six individual runs as follows below:

RUN #1 – Static (Solution 101) with extreme boundary conditions that react the entire load through the four bolts in the vacuum vessel support - total vessel load of 160,000 lbs, but, scaled to 40,000.lbs for a ninety degree sector. This simulation was used to investigate the maximum possible stresses on the VV/Chair welded locations. This case is considered overly conservative.

RUN #2 – Static simulation with relaxed boundary condition, spreading the support loads through the pad and not just the bolts, using the same SPCs, MPCs, and loads as in the RUN #1. With this simulation additional information was demonstrated for the maximum expected calculations.

RUN #3 – Static simulation with final and complete model with RBE2(rigid link) elements instead of GAPS. SPCs are changed to the vertical beam location where angled floor brackets connect to it. MPCs and applied load pressures are as in the prior runs. This run correctly simulates the overall intended analyses approach.

RUN #4 – Non linear run (Solution 106) where RBE2s were replaced with the proper GAP elements which are aligned to Coordinate #2 with element X-direction in the negative vertical direction. Elements slide (with a coefficient of friction assumed to be 0.3) in the element Y and Z direction. The obtained results are very similar to the data from RUN #3. The reason for this is that there is not much global radial motion without the thermal effects on the Vacuum Vessel.

RUN #5 – Non linear run with the addition of the 37,000. Lbs. link/clevis load as shear parallel to the vacuum vessel surface. All other loads and boundary conditions are identical to RUN #4. Obtained results values for this case increase since an addition load was added. Locations for the maximum values are relocated but remain reasonable for the material allowable. This simulation is most representative of the standard device operating environment since it includes the ring/clamp vacuum vessel clevis forces.

RUN #6 – Non linear “BAKEOUT” simulation. This is a special run which includes the combination of the mechanical loads due to the vacuum vessel weight and the possible worst case thermal differences during the “BAKEOUT” event as the structure reaches a steady state condition after 1,200 minutes of temperature application. Same scenario was used to predict this condition for the PF 4 and 5 support brackets where temperature profile was measured and recorded during the actual “BAKEOUT” operation. For RUN #6, previous data was converted from degrees C to F and distributed accordingly on the complete simulation using element groups as described in the appropriate powerpoint slides. It is assumed that this is the best possible representation for this RUN #6 case. (please see the complete set of these attached powerpoint slides).

Conclusion (Specify whether or not the purpose of the calculation was accomplished.)

Based on the above described simulation the following final list shows important findings for the Redesigned Vessel Support Bracket assembly and the connecting structure. Also, please see the summary slide in the power point file. Conclusions are as follows:

- Calculated stresses and strains are well within the material allowable,
- Maximum stresses for the welded locations are equal to 16,200 psi
- Maximum strains for the welded locations are equal to .00047
- Maximum stresses for the VV-chair location are equal to 21,500 psi
- Maximum strains for the VV-chair location are equal .00062

Note: All the maximum weld stress values are calculated by RUN #6 which includes the “BAKEOUT” temperature scenario. The results obtained in RUN #5 are slightly smaller but important peak stress locations are different.

Strong Recommendation: to carefully weld the assembly connecting corners since all maximum strains and stresses are concentrated in these locations. These additional welds should decrease the peak values making the design stronger! Please see slide #30.

Preparing Engineer's printed name, signature, and date

Peter Rogoff 12/12/2011 _____

I have reviewed this calculation and, to my professional satisfaction, it is properly performed and correct.

Checker's printed name, signature, and date

Irving Zatz _____

References

Reference for 37000 lbs: VV-Clevis applied load. (see power point slides/data) – [Added by P. Rogoff]

[1] Analysis of TF Outer Leg, Han Zhang, Calculation Number NSTXU-CALC-132-04,

Reference for standard brackets/chairs and chair loads:

[2] NSTX-CALC-13-001-00 Rev 1 Global Model – Model Description, Mesh Generation, Results, Peter H. Titus

Reference for PF4/5

[3] Analysis of Existing and Upgrade PF4/5 Coils and Supports – With Alternating Columns. NSTX-CALC-12-05-00 Rev 0 P. Titus March 2011

Reference for Criteria:

[4] NSTX Structural Design Criteria Document, NSTX_DesCrit_IJ_080103.doc I. Zatz

[5] NSTX Design Point Sept 8 2009 http://www.pppl.gov/~neumeyer/NSTX_CSU/Design_Point.html

[6] Fusion Engineering and Design 54 (2001) 275–319, Engineering design of the National Spherical Torus, Experiment, C. Neumeyer et.al, Page 286 quotes 100,000 lbs for the total vacuum vessel weight

DCPS Input:

In deriving the net loads on the vertical columns, it is assumed that all the magnetic loads sum to zero, and that the centerstack load inventory - PF1 a,b, upper and lower, and the OH, is supported by the pedestal, and an equal and opposite load is imposed on the vessel legs. The net load from the coils is 53445 lbs [5], rounded up to 60,000 lbs The tokamak is assumed to weigh 100,000 lbs [6]. The net dead load is 160,000 lbs or 40,000 lbs per column, or 177935 N per column. An initial setting for the DCPS would be to limit the sum of PF1a,b, U&L, and OH Upward vertical loading to 60,000 lbs. Upward vertical loading of the inner PF coils supported by the pedestal implies an additional downward loading on the vessel support columns of an equal magnitude.

The total mechanical load applied to all simulation runs is 40,000 lbs for the 90 degree VV sector. This is based on the Ref (5) and (6) requirements. [Added by P. Rogoff]

NSTXU PROJECT

Vessel-Support-Chair.ppt

Complete simulation justification

P.R. March 2012

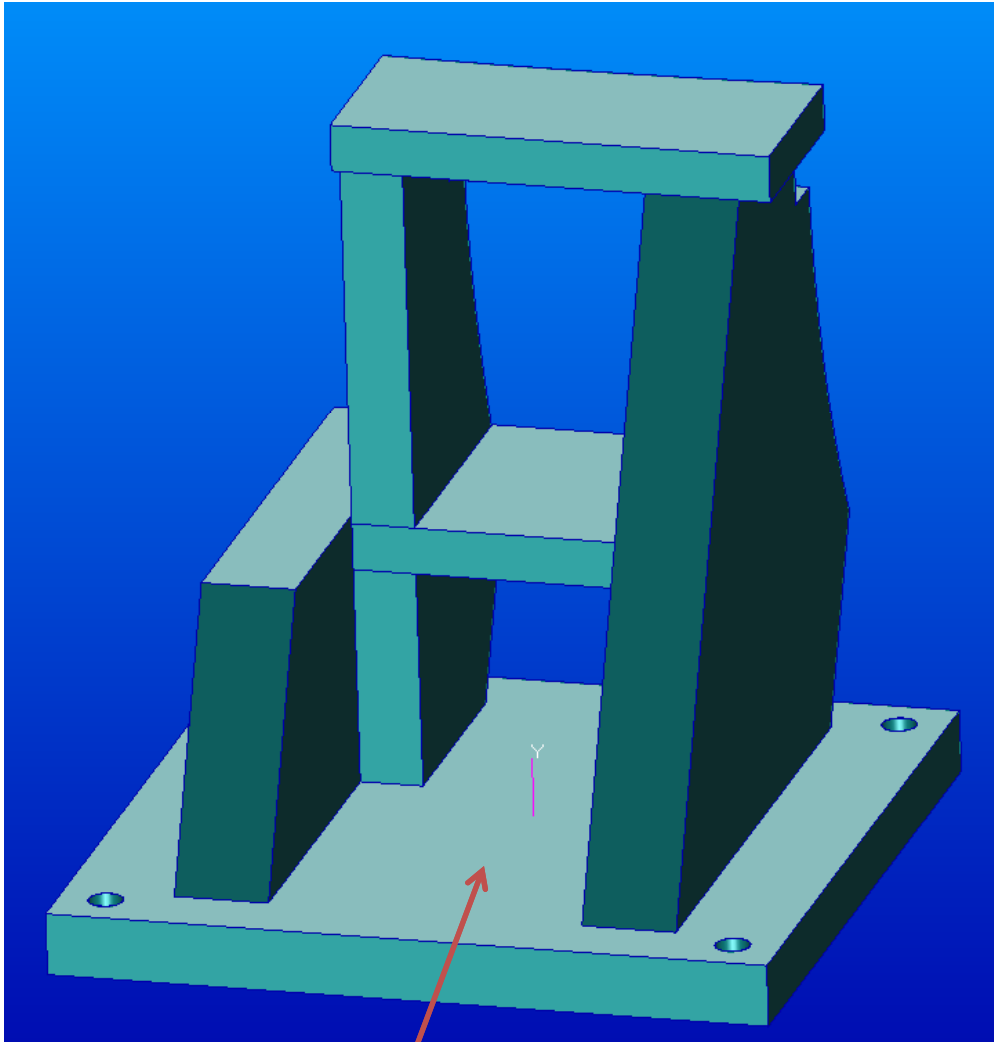

VV-support-attach-011812.igs

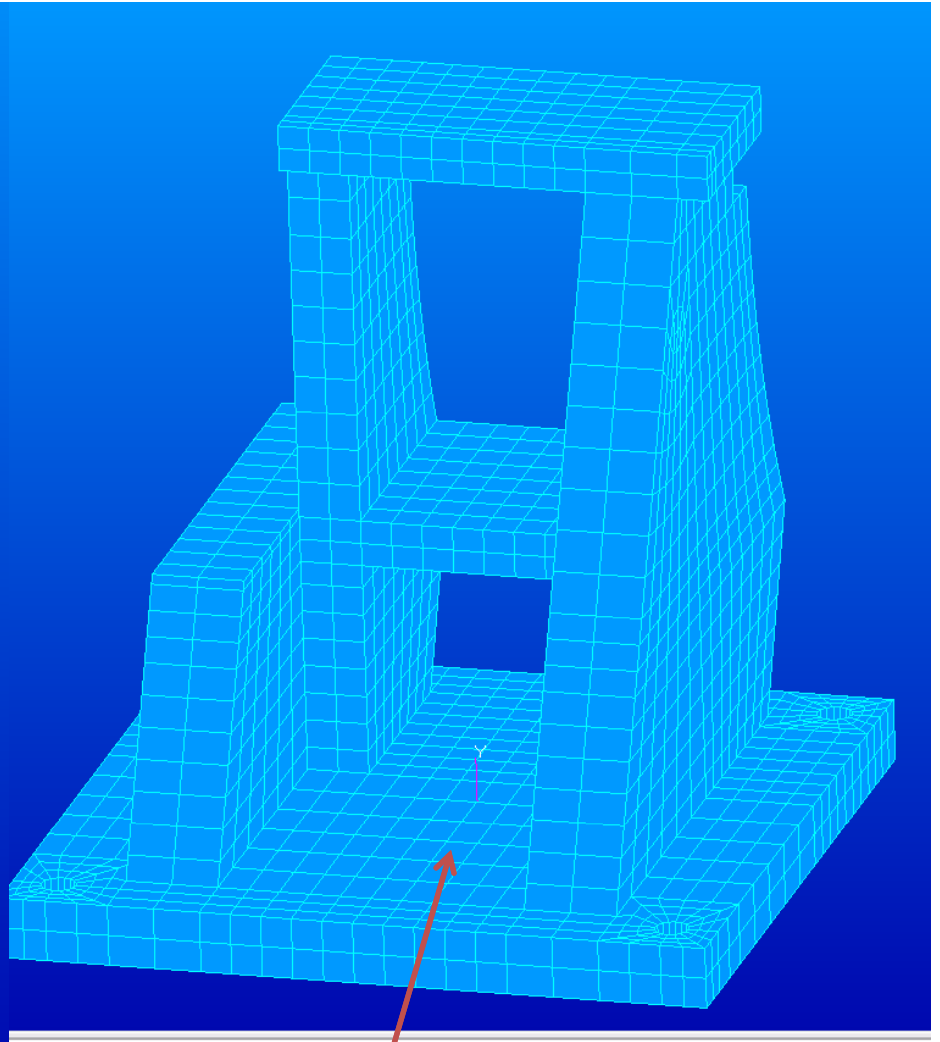

Nastran FEA all Hex8 elements

Question: How is this welded, assume weld size = 3/8 inch?

Redesigned VV support chair

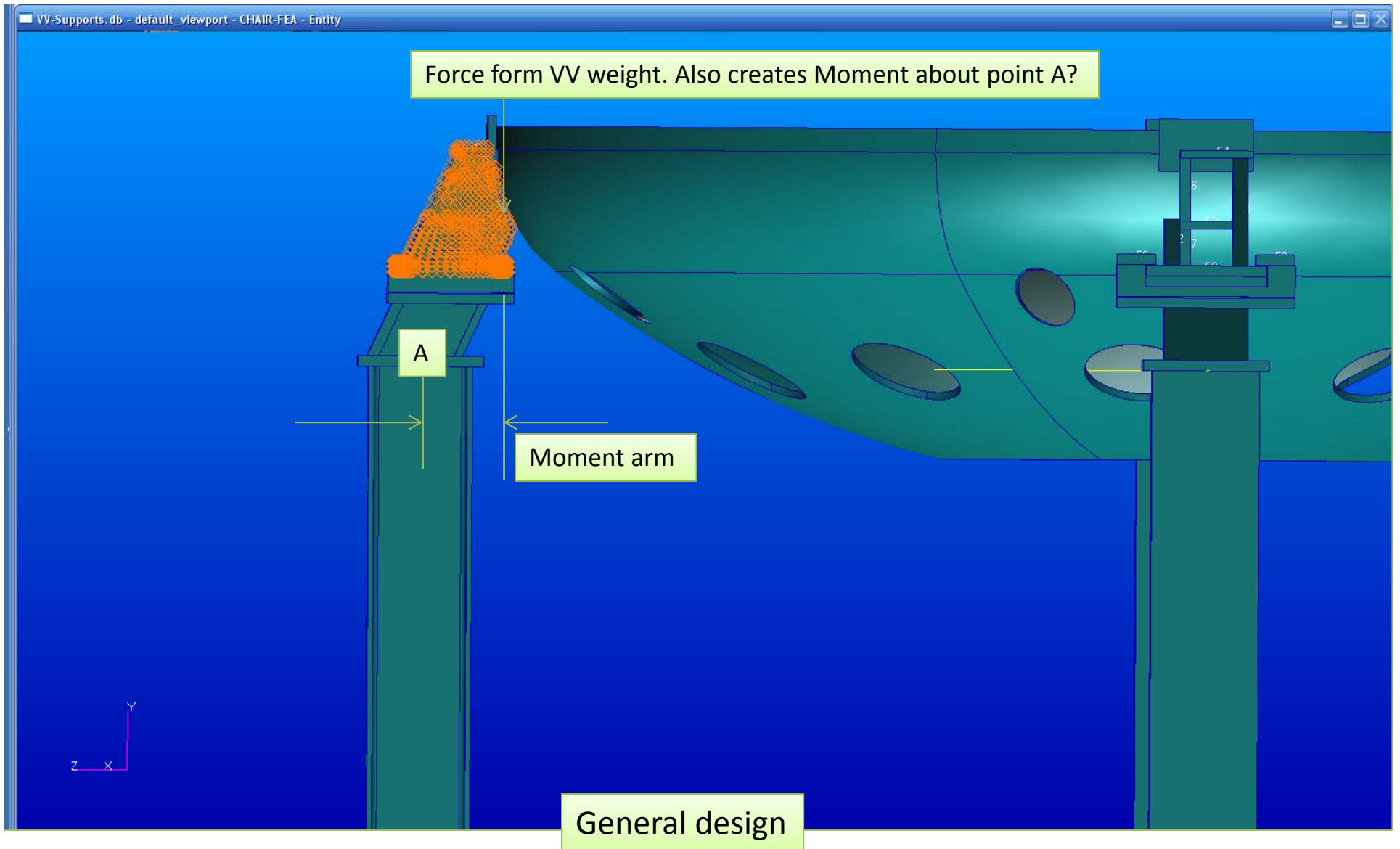

VV – Chair support configuration
[Complete geometry provided by M. Smith, 1/2012]

General Forces and Moments on the VVChair

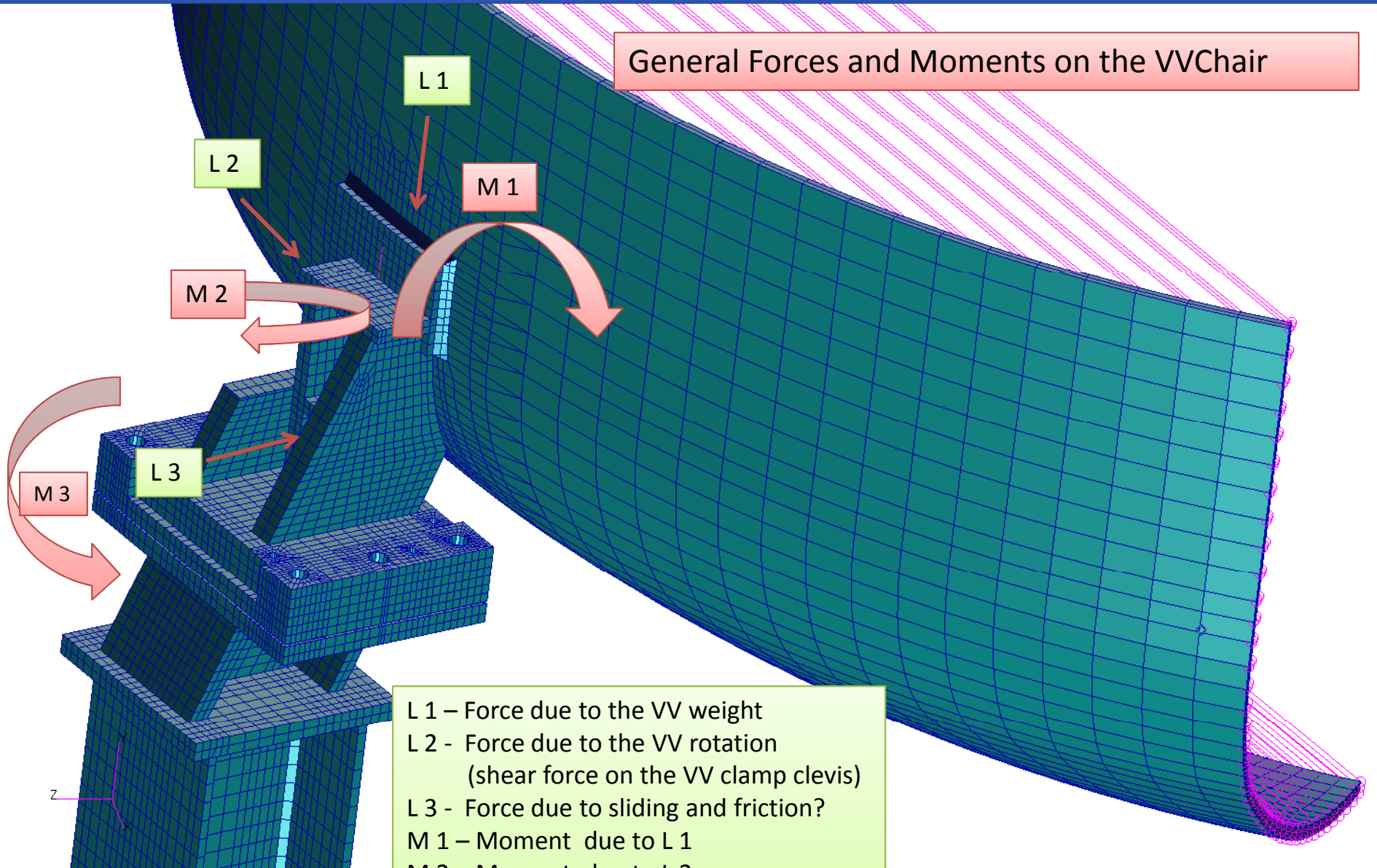

- L 1 – Force due to the VV weight
- L 2 - Force due to the VV rotation
(shear force on the VV clamp clevis)
- L 3 - Force due to sliding and friction?
- M 1 – Moment due to L 1
- M 2 – Moment due to L 2
- M 3 – Moment due to L 3

Note: Force L 3 is a function of “L 1” and the coefficient of friction at the slide plate/cradle interface

```

$ NASTRAN input file created by the MSC FEA 2010.1.2 64-Bit input file
$ translator on March 08, 2012 at 12:06:33.
$ Nonlinear Static Analysis, Database
SOL 106
CEND
TITLE = MSC.NASTRAN JOB CREATED ON 17-FEB-12 AT 08:48:38
ECHO = NONE
MPC = 20134
SUBCASE 1
  TITLE=Non-Linear
  SUBTITLE=RUN5-Loads
  NLPARM = 1
  SPC = 2
  LOAD = 2
  DISPLACEMENT(SORT1,REAL)=ALL
  SPCFORCES(SORT1,REAL)=ALL
  STRAIN(SORT1,REAL,VONMISES,STRUCUR,BILIN)=ALL
  STRESS(SORT1,REAL,VONMISES,BILIN)=ALL
$ Direct Text Input for this Subcase
BEGIN BULK
$ Direct Text Input for Bulk Data
PARAM POST 0
PARAM AUTOSPC YES
PARAM PRTMAXIM YES
NLPARM 1 10 AUTO 5 25 P NO
      .01

```

Complete model input file set-up
 Note RUN #5 chosen for the demonstration (other runs are similar).

General Executive deck

```

$ Elements and Element Properties for region : sliding-Gaps
PGAP 2 0. 3.+7 500. 1.+7 .3 .3
-1.
$ Pset: "sliding-Gaps" will be imported as: "pgap.2"
CGAP 94612 2 102192 127702 2
CGAP 94613 2 102195 128013 2

```

GAPs definition

```

MODEL SUMMARY
NUMBER OF GRID POINTS = 34815
NUMBER OF CGAP ELEMENTS = 660
NUMBER OF CHEXA ELEMENTS = 23184
NUMBER OF CPENTA ELEMENTS = 1336
NUMBER OF CTETRA ELEMENTS = 33
NUMBER OF RBE2 ELEMENTS = 977
17-FEB-12 AT 08:48:38

```

Total load due to the Pressure

Simulation grid and element statistics

Clevis loads (only for run #5)

RESULTANTS ABOUT ORIGIN OF SUPERELEMENT BASIC COORDINATE SYSTEM IN SUPERELEMENT BASIC SYSTEM COORDINATE

SUBCASE/ DAREA ID	LOAD TYPE	T1	T2	T3	R1	R2	R3	
0								
0	1	FX	3.576299E+04	-----	-----	2.319899E+06	1.403519E+06	
		FY	-----	-3.998594E+04	-----	-----	-9.220052E+05	
		FZ	-----	-----	-9.487278E+03	3.723282E+05	-----	
		MX	-----	-----	-----	0.000000E+00	-----	
		MY	-----	-----	-----	-----	-----	
		MZ	-----	-----	-----	-----	0.000000E+00	
	TOTALS		3.576299E+04	-3.998594E+04	-9.487278E+03	2.593534E+06	2.483160E+06	4.815134E+05
1						MARCH 8, 2012	MSC.NASTRAN	

Resultant applied loads from the .f06 output

VV Support configuration FEA simulation

MPCs simulate
Cyclic Symmetry
3 – dof (1,2,3)
Hexa 8- elements

SPCs (1,2,3)
Fixity where
Braces are located

Redesigned Chair

Slide plate

Cradle

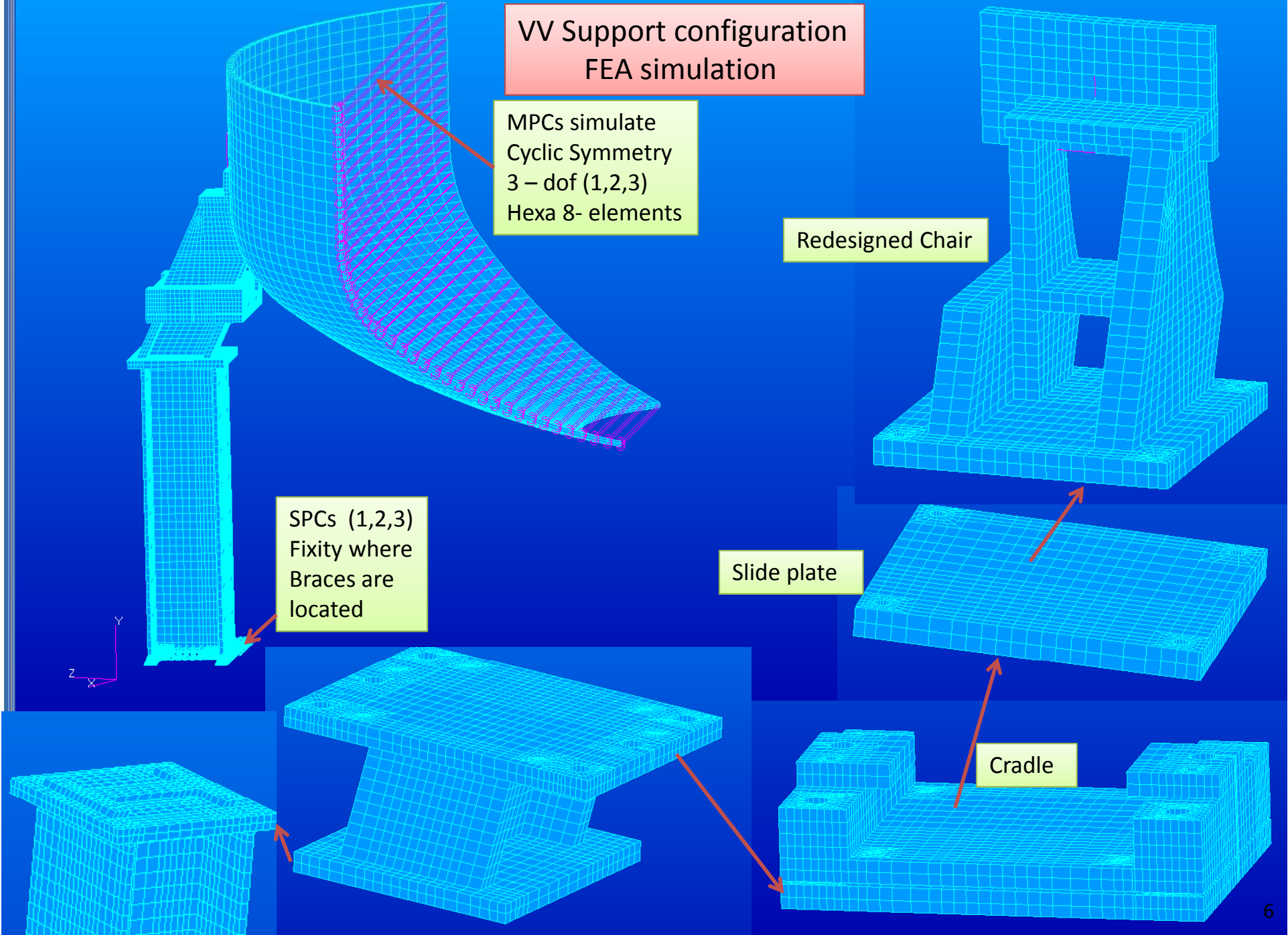

RUN # 1

Static Test run #1 and Simulation general loads and fixities

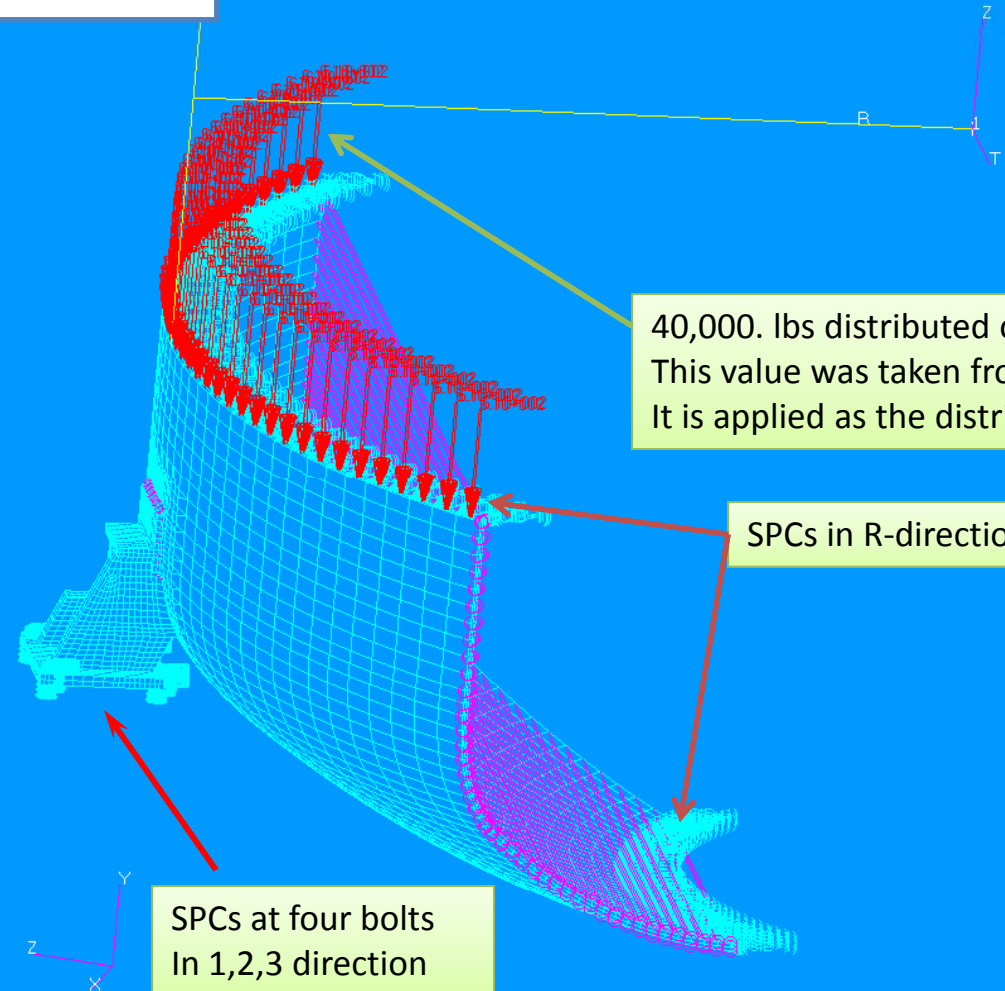

Db --- Statics
File -- ChairVVStatics.bdf
This is a test run to check
Connections to the VV

40,000. lbs distributed over the VV thickness and 90 degree sector.
This value was taken from the previous analyses estimates.
It is applied as the distributed pressure.

SPCs in R-direction only

SPCs at four bolts
In 1,2,3 direction

Results are in ChairVVStatics.xdb

MSC FEA 2010.1.2 64-Bit 24-Feb-12 11:37:20

Fringe: Default, A1:Static Subcase, Displacements, Translational, Magnitude, (NON-LAYERED)

RUN # 1 Results

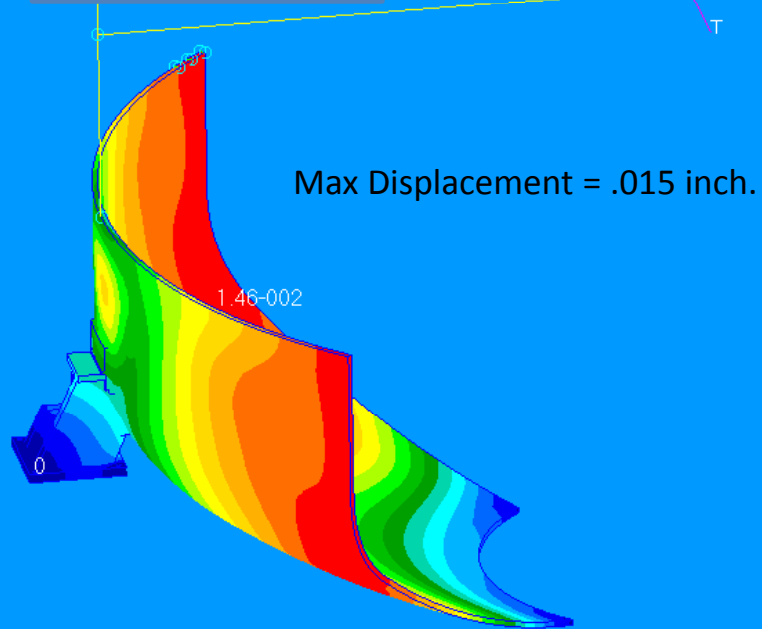

MSC FEA 2010.1.2 64-Bit 24-Feb-12 11:44:14

Fringe: Default, A1:Static Subcase, Stress Tensor, , von Mises, (NON-LAYERED)

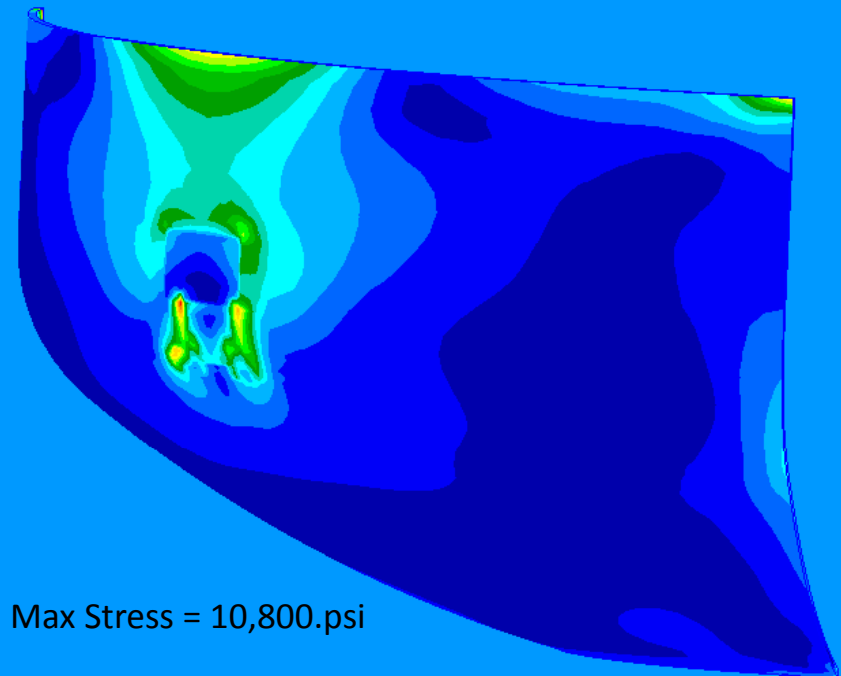

MSC FEA 2010.1.2 64-Bit 24-Feb-12 11:47:06

Fringe: Default, A1:Static Subcase, Stress Tensor, , von Mises, (NON-LAYERED)

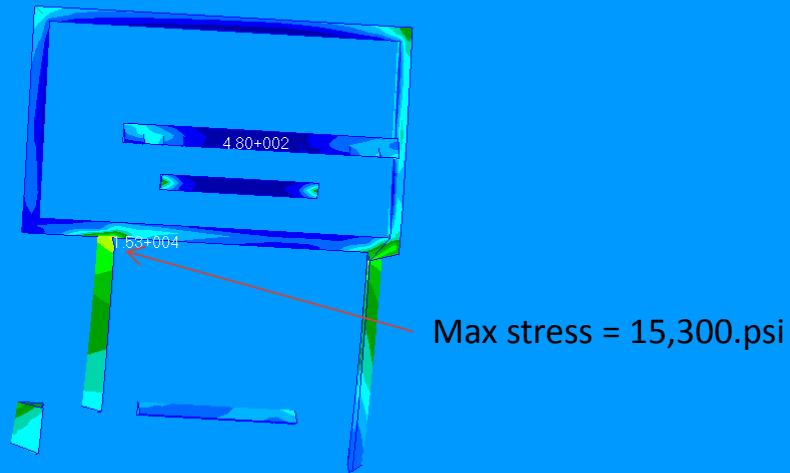

MSC FEA 2010.1.2 64-Bit 24-Feb-12 11:52:31

Fringe: Default, A1:Static Subcase, Stress Tensor, , von Mises, (NON-LAYERED)

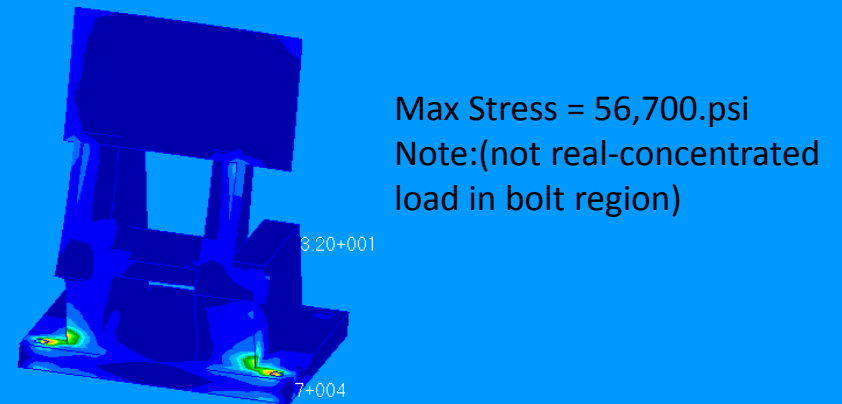

RUN #2

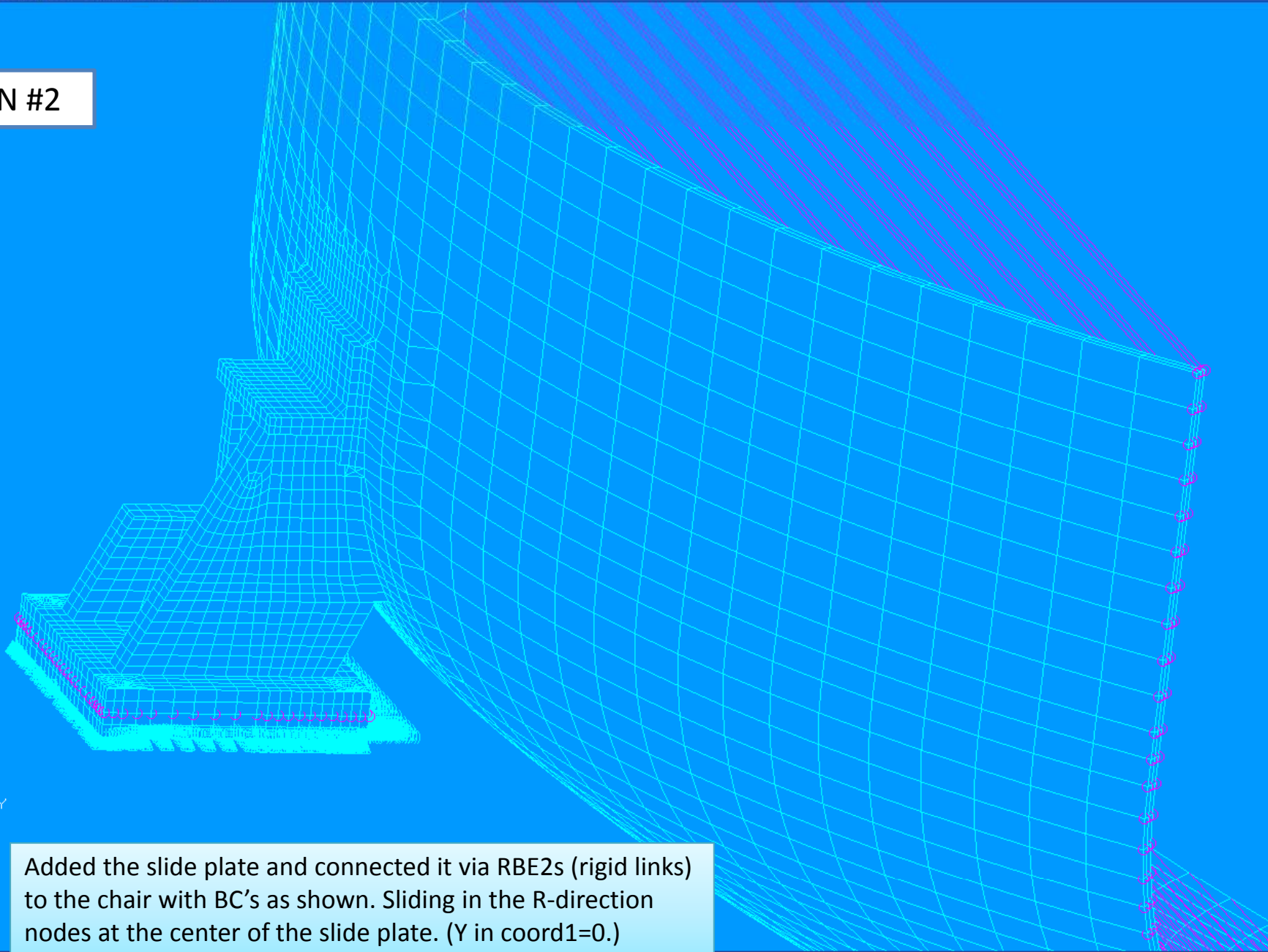

Added the slide plate and connected it via RBE2s (rigid links) to the chair with BC's as shown. Sliding in the R-direction nodes at the center of the slide plate. (Y in coord1=0.)

RUN #2 Results

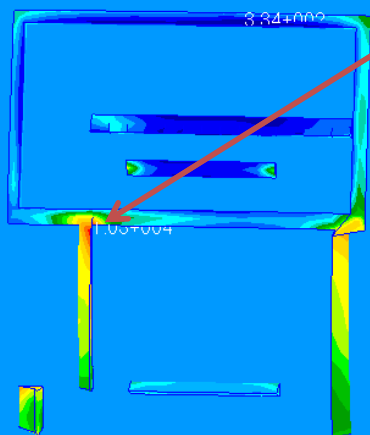
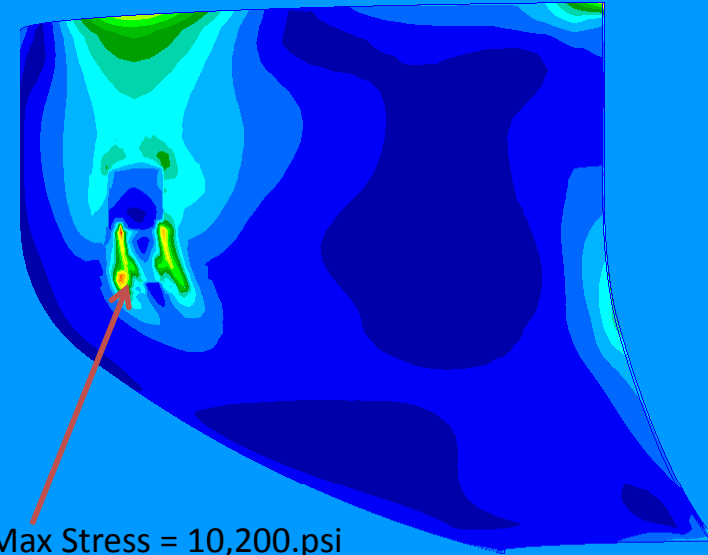
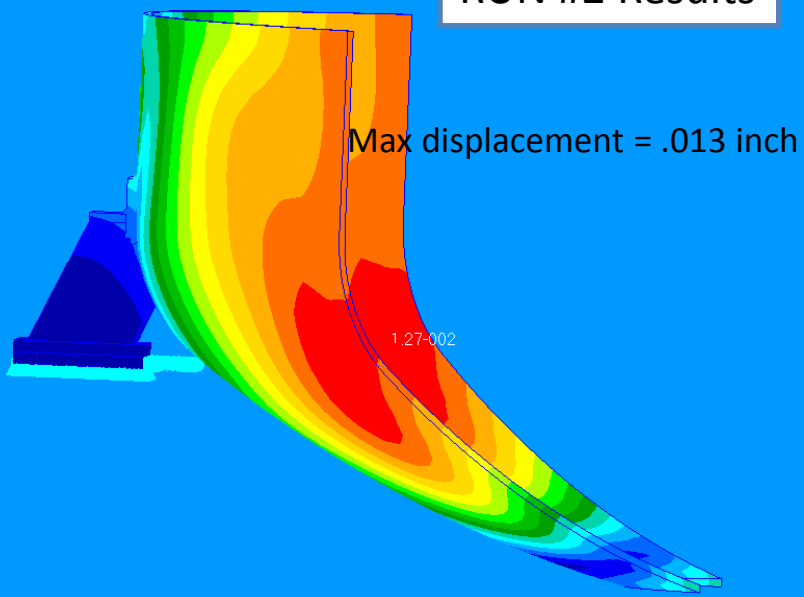

Welds between the Chair and the VV

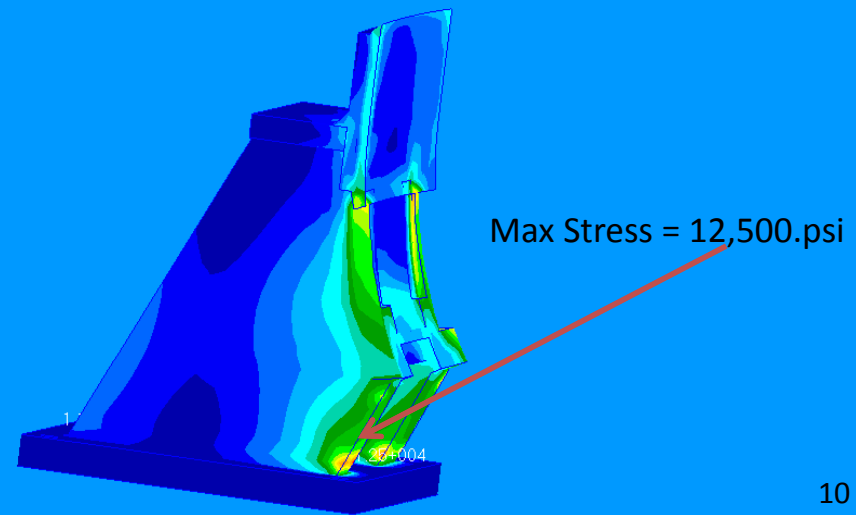

RUN #3

Sol 101 –First, set up a linear static run with zero-length GAPS along the pad surface that act as rigid links in this solution.

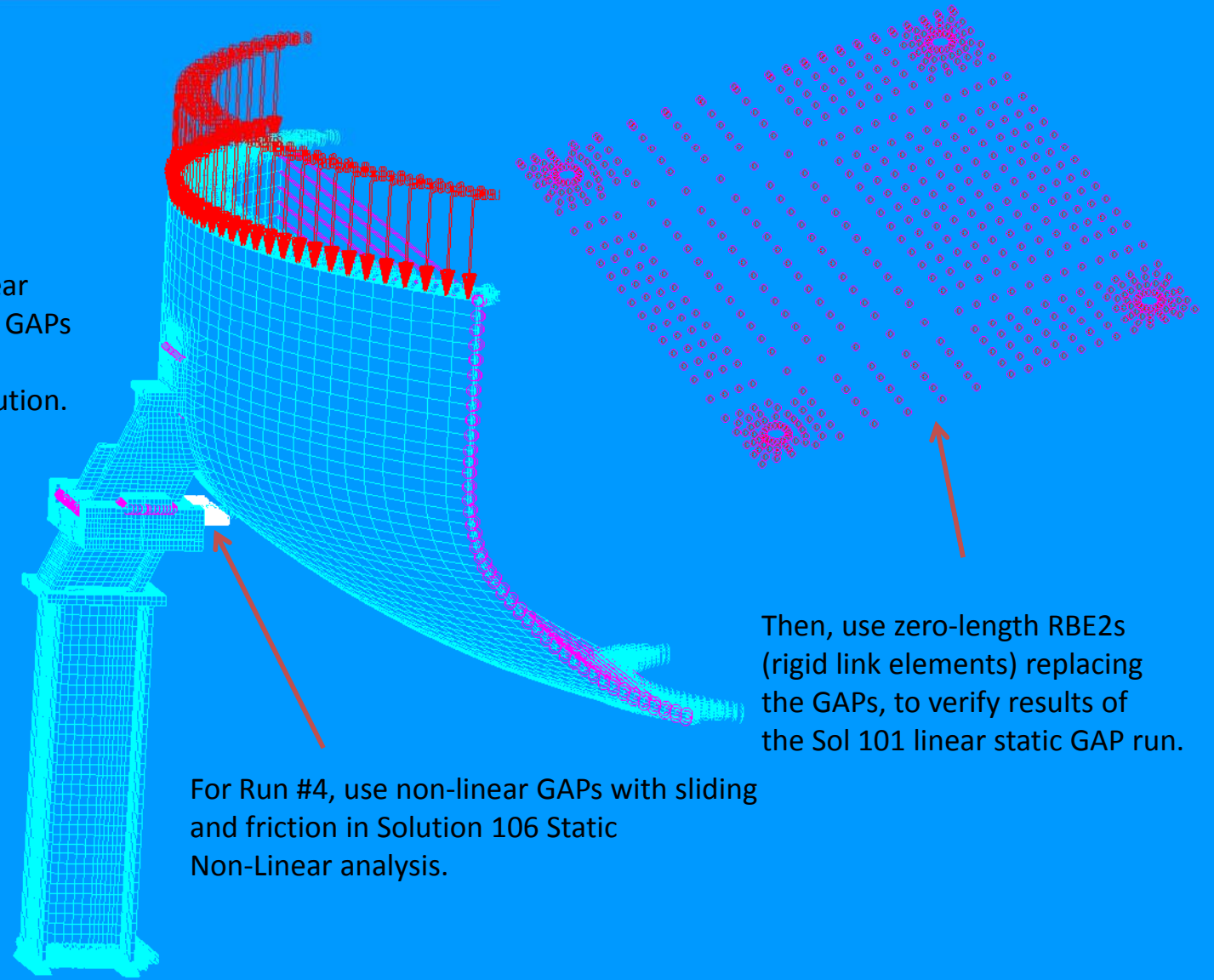

Then, use zero-length RBE2s (rigid link elements) replacing the GAPS, to verify results of the Sol 101 linear static GAP run.

For Run #4, use non-linear GAPS with sliding and friction in Solution 106 Static Non-Linear analysis.

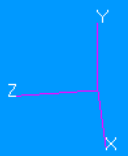

General orientation of
GAP elements (660)

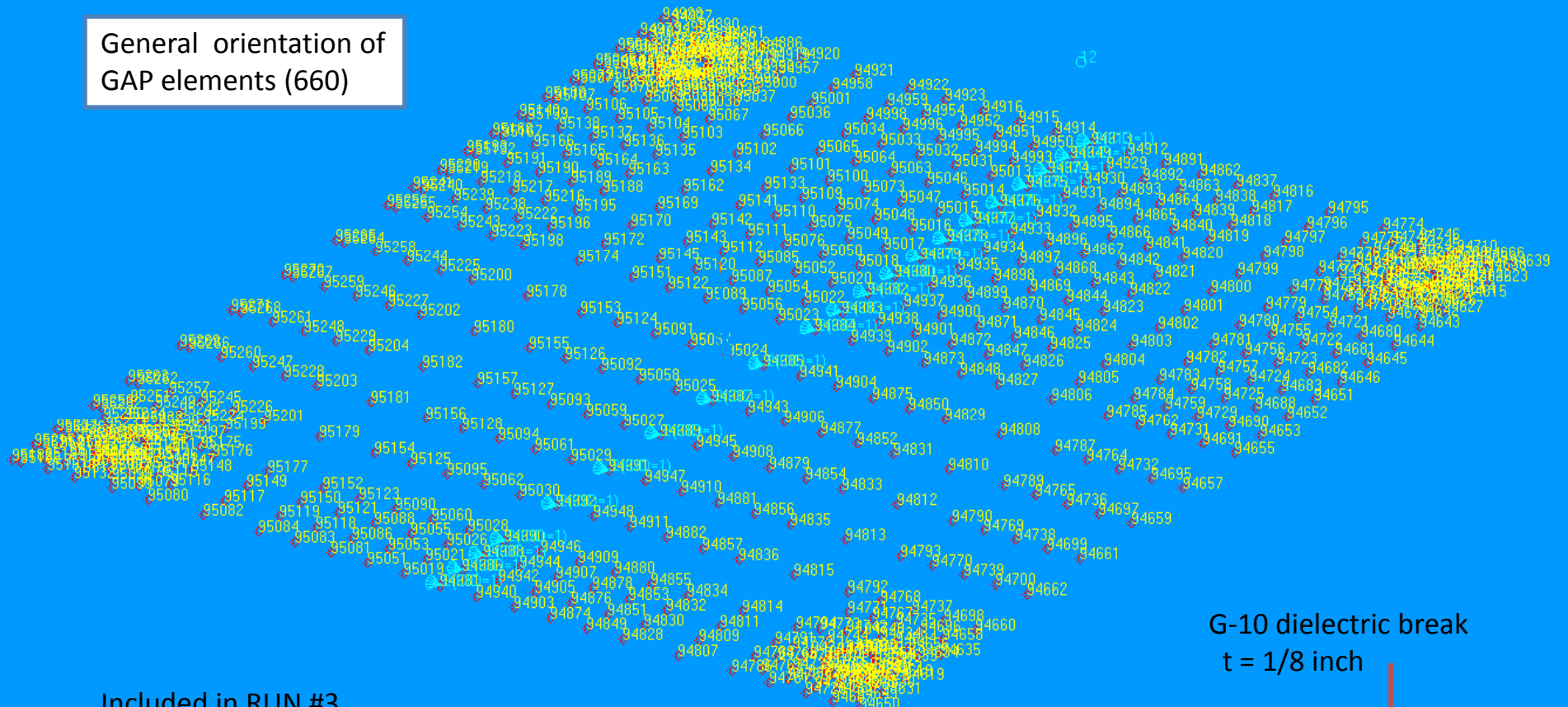

Included in RUN #3

G-10 dielectric break
t = 1/8 inch



```

PARAM      POST      0
PARAM      PRTMAXIM YES
$ Elements and Element Properties for region : sliding-Gaps
PGAP       1         0.      3.+7  500.  1.+7  .3      .3
          -1.
$ Pset: "sliding-Gaps" will be imported as: "pgap.1"
CGAP       94612    1         102192 127702 0.      -1.      0.
CGAP       94613    1         102195 128013 0.      -1.      0.
CGAP       94614    1         102199 128016 0.      -1.      0.
CGAP       94615    1         102201 128015 0.      -1.      0.
CGAP       94616    1         102204 131457 0.      -1.      0.
    
```

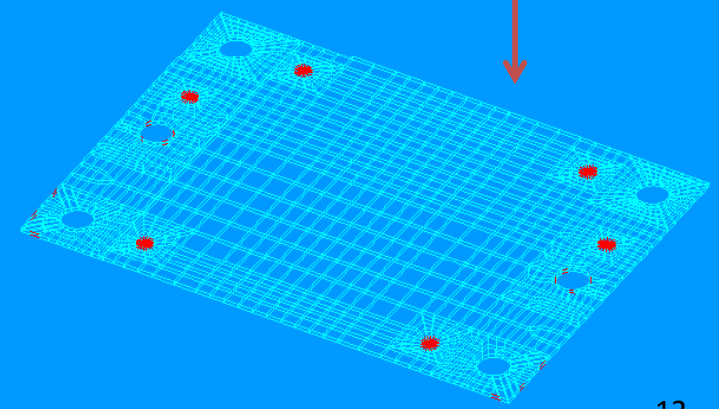

Between the cradle and Vertical support

RUN #3 Results

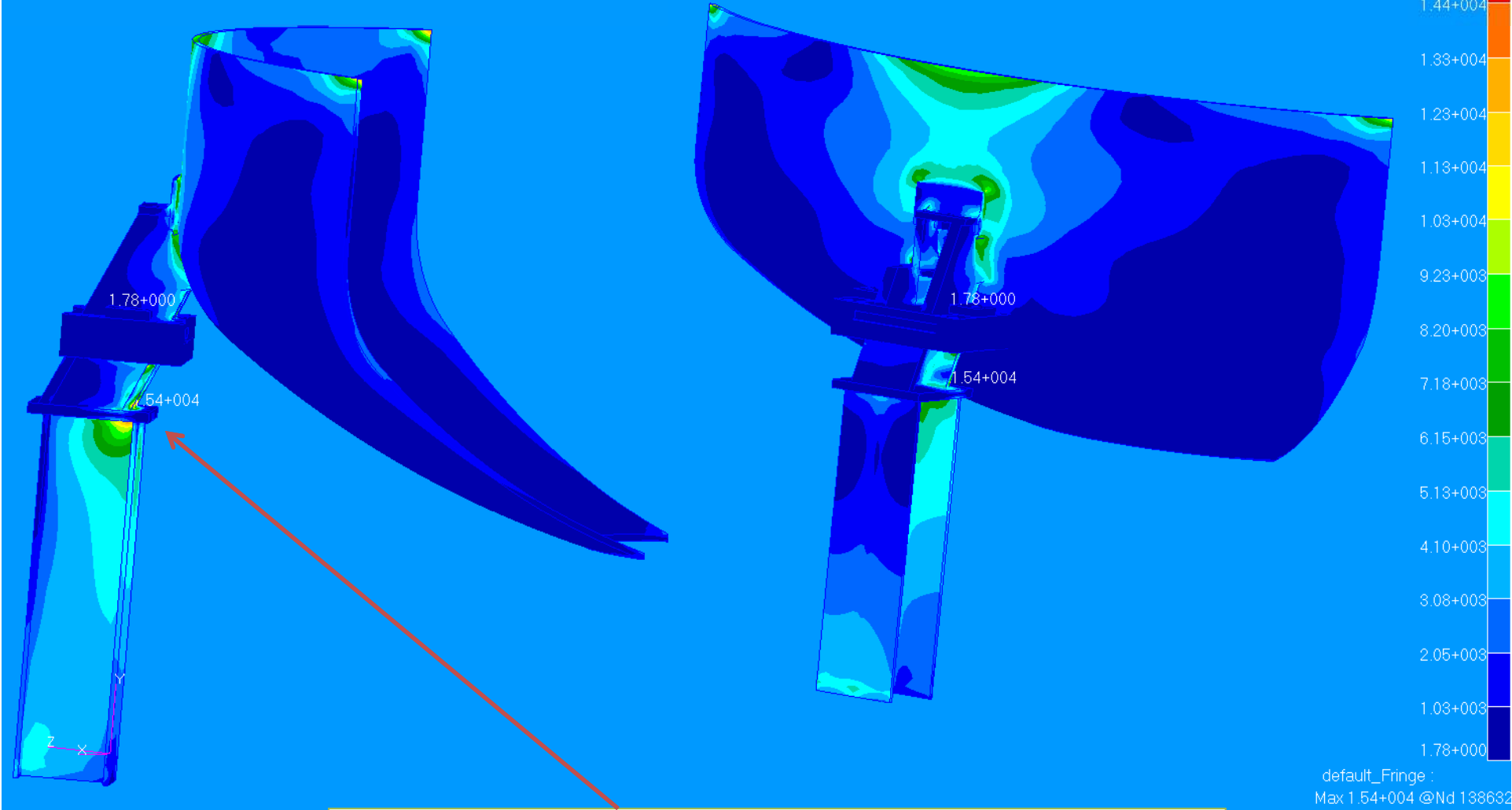

Maximum Von Mises stress on the total system for this run = 15,400. psi.

default_Fringe :
Max 1.54+004 @Nd 138632

RUN #3 Results

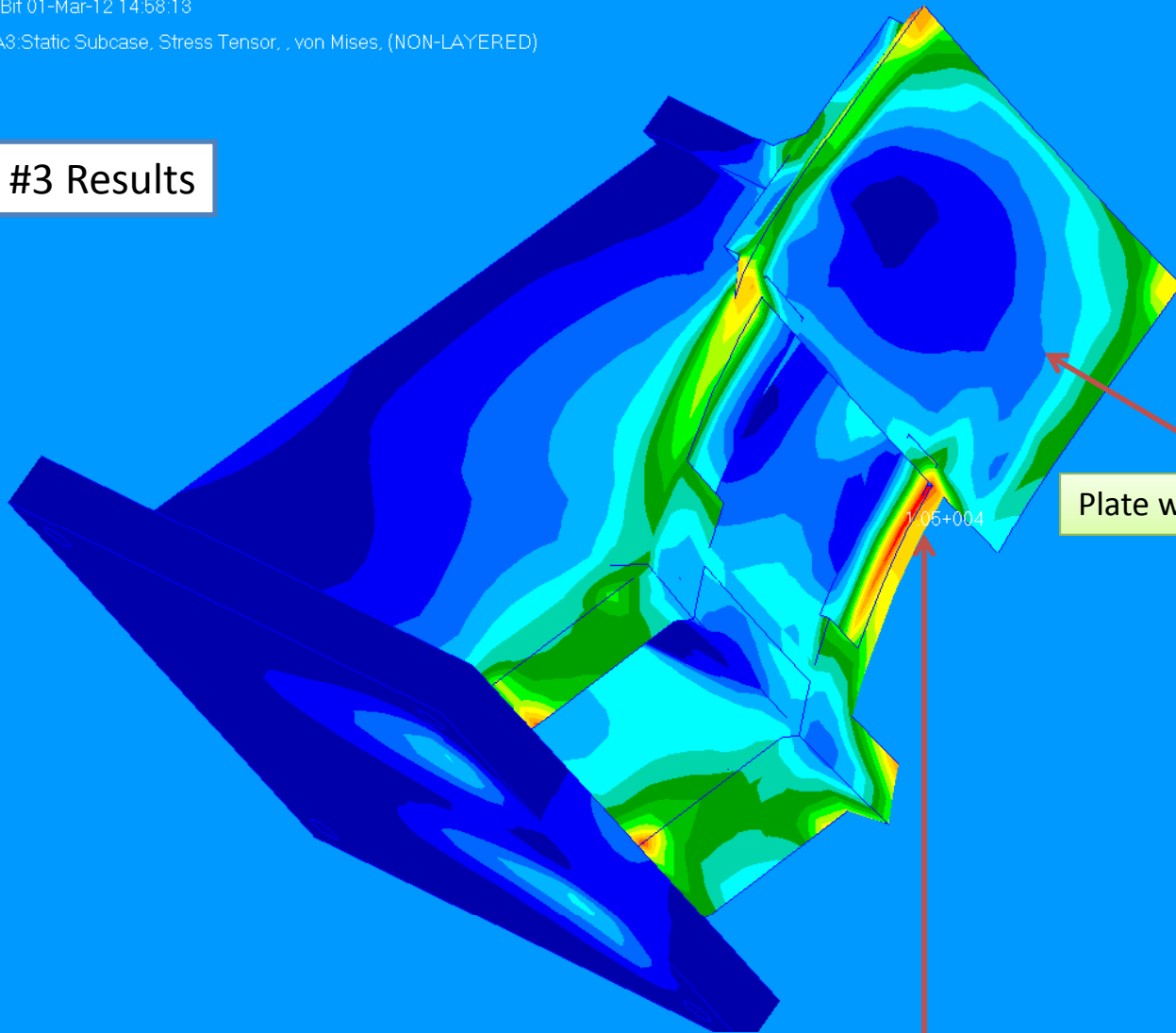
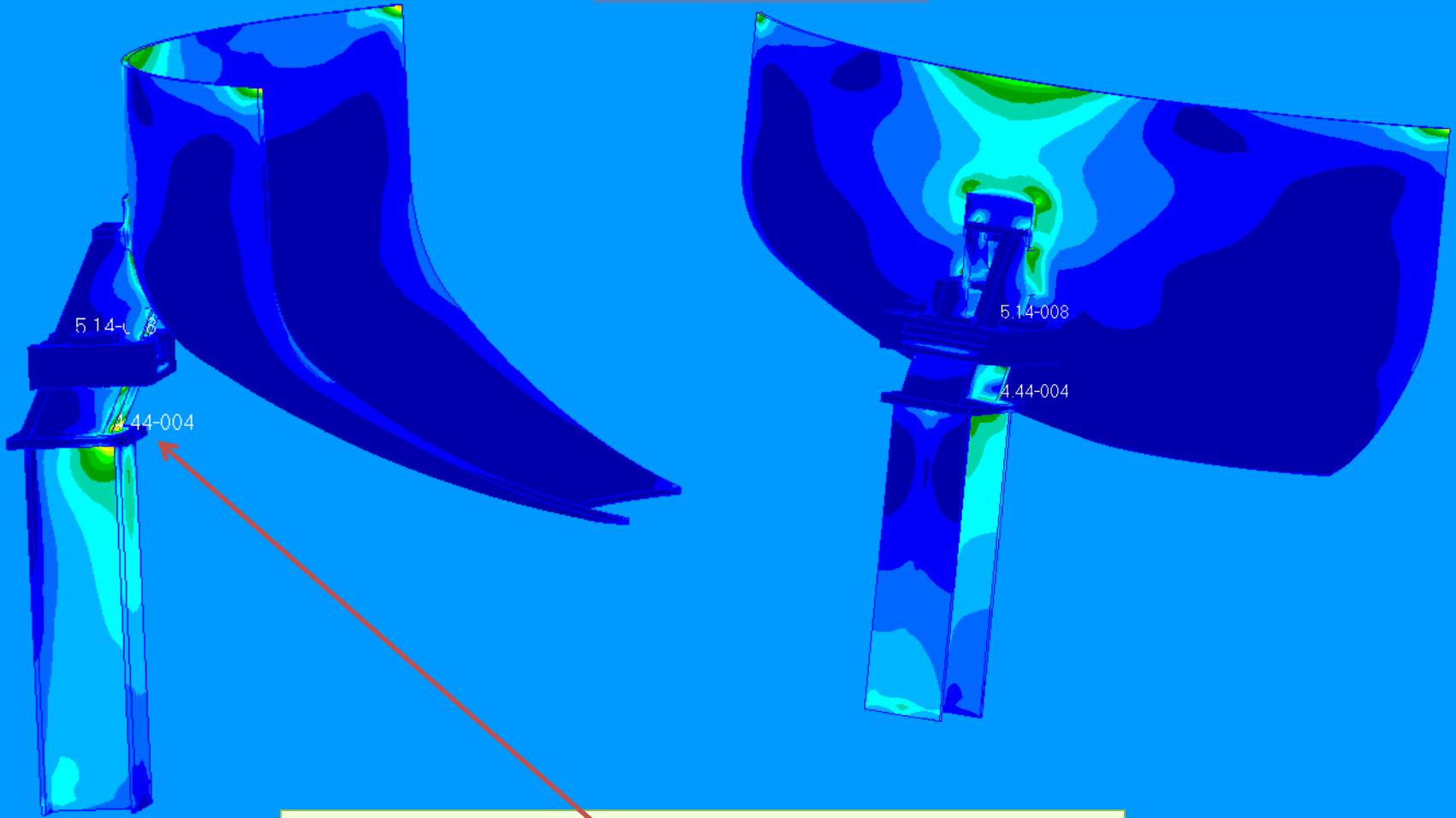

Plate welded to the VV

VV Chair with welds, Maximum Von Mises Stress = 10,500.psi

default_Fringe :
Max 1.05+004 @Nd 13113

RUN #3 Results



Maximum strain on the total system for this run = .00044

default_Fringe :
Max 4.44-004 @Nd 138632

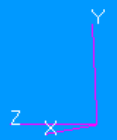

RUN #3 Results

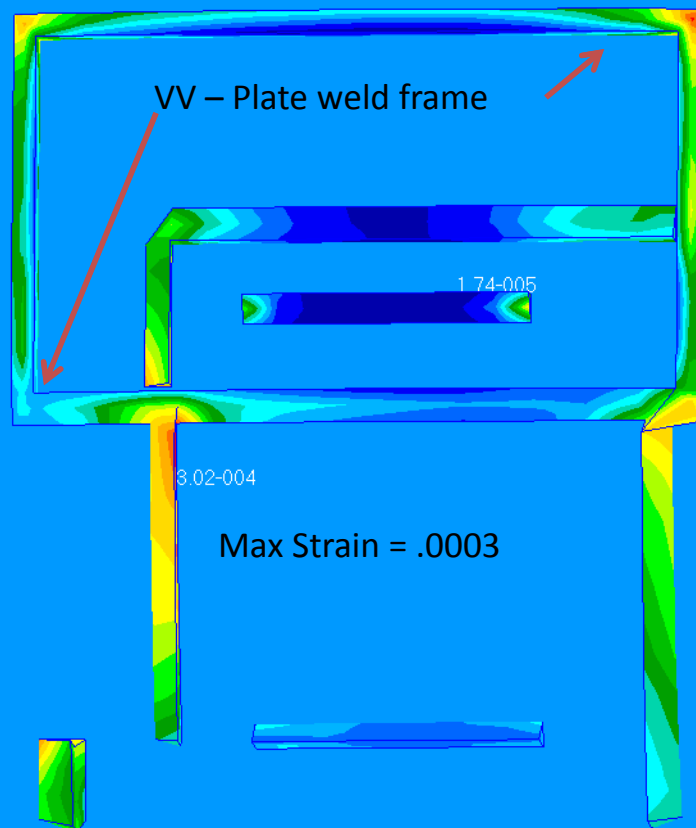
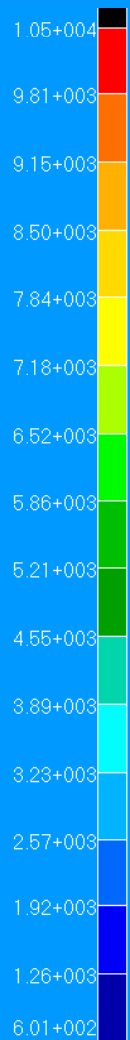
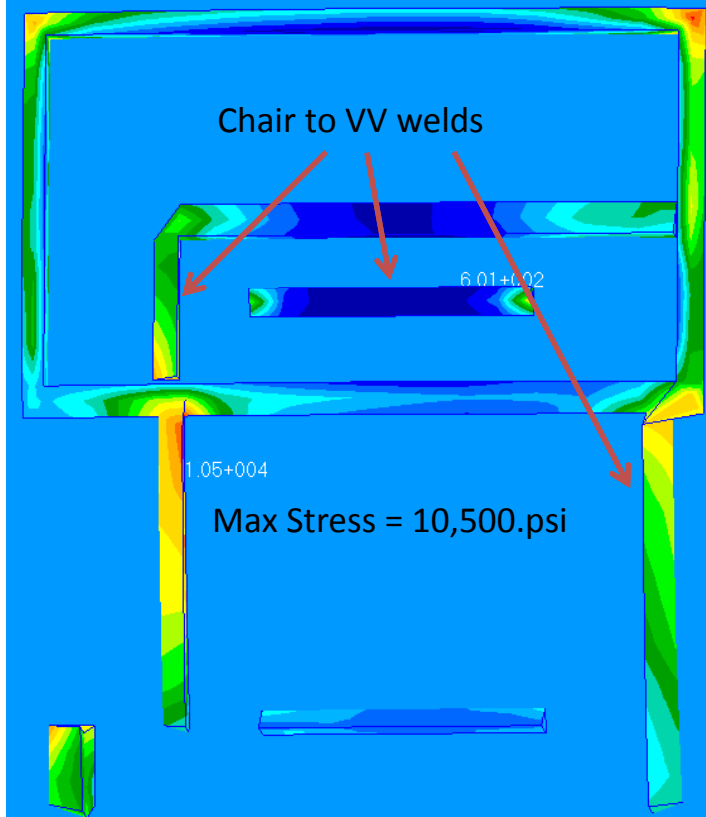

default_Fringe :
Max 3.02-004 @Nd 13113
Min 1.74-005 @Nd 12001

Results from the pure linear run where GAPS are replaced by the RBE2s

RUN #4 Non Linear Static Solution (106)

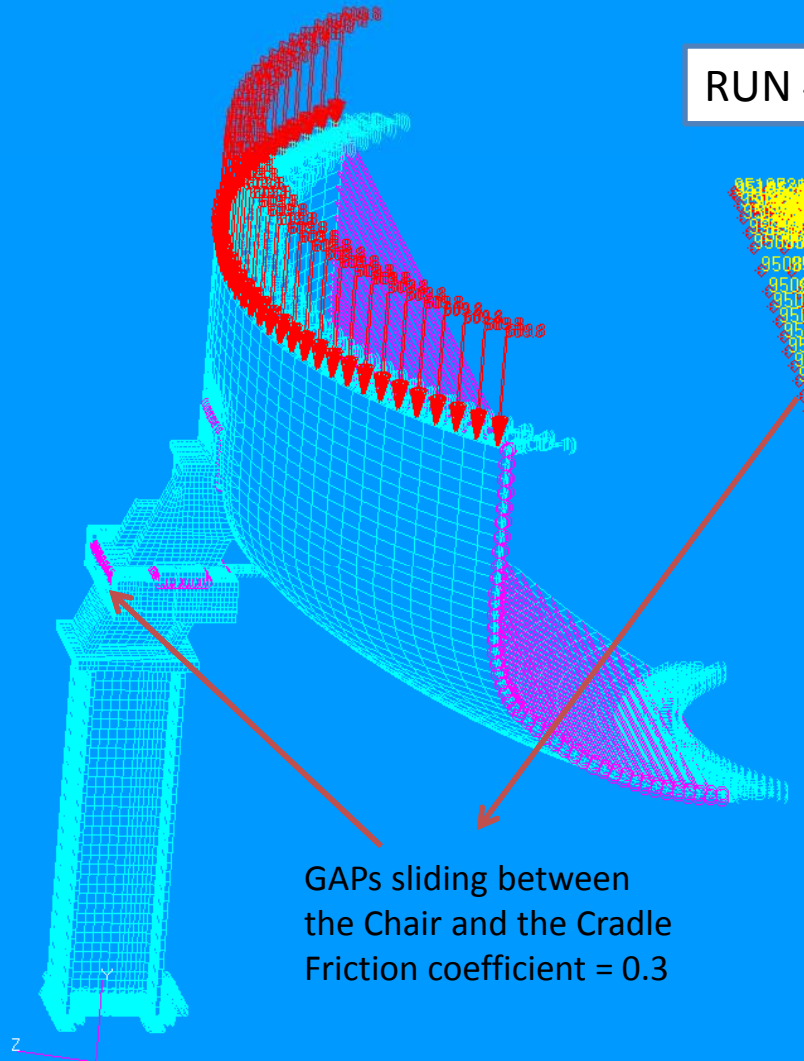

GAPs sliding between
the Chair and the Cradle
Friction coefficient = 0.3

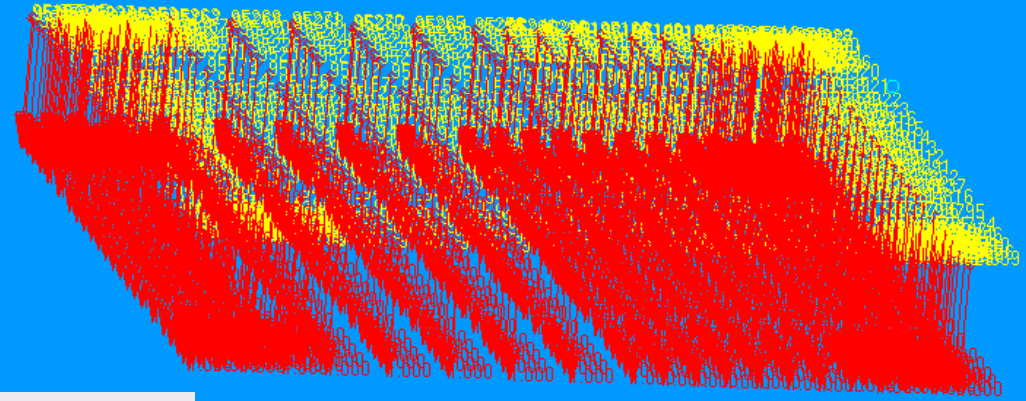
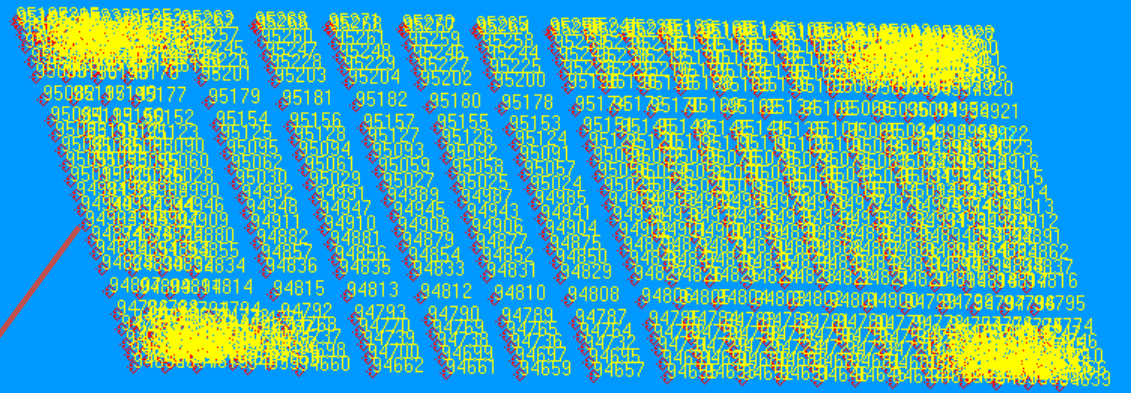

GAPs orientation in the -Y direction

Load Case "RUN4-Loads"

	Type	Scale Factor	Priority
Slide_Fic_cen	Displacement	1.	Add
Support_Bot	Displacement	1.	Add
VV-Fixity	Displacement	1.	Add
VV-Fixity-Bot	Displacement	1.	Add
Pres40000	Pressure	1.	Add

RUN #4 -Results

MSC FEA 2010.1.2 64-Bit 06-Mar-12 10:02:14

Fringe: RUN4-Loads, A4:Non-linear: 100. % of Load, Displacements, Translational, Magnitude, (NON-LAYERED)

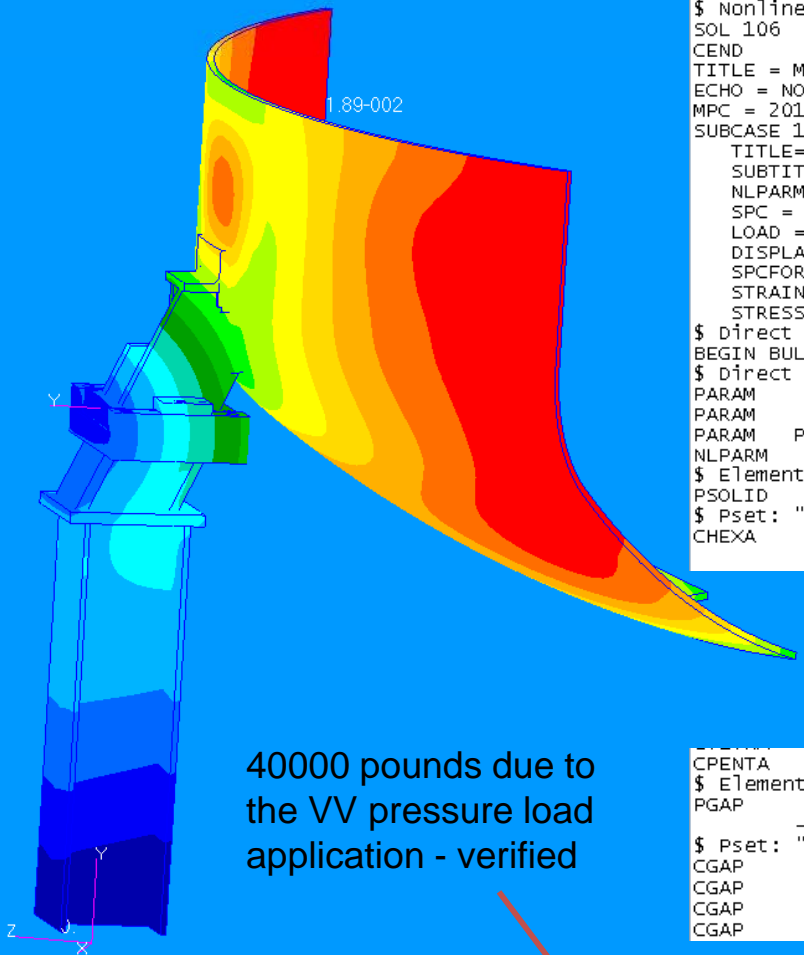

40000 pounds due to the VV pressure load application - verified

```

$ Nonlinear Static Analysis, Database
SOL 106
CEND
TITLE = MSC.NASTRAN JOB CREATED ON 17-FEB-12 AT 08:48:38
ECHO = NONE
MPC = 20134
SUBCASE 1
  TITLE=Non Linear
  SUBTITLE=RUN4-Loads
  NLPARM = 1
  SPC = 2
  LOAD = 2
  DISPLACEMENT(SORT1,REAL)=ALL
  SPCFORCES(SORT1,REAL)=ALL
  STRAIN(SORT1,REAL,VONMISES,STRCUR,BILIN)=ALL
  STRESS(SORT1,REAL,VONMISES,BILIN)=ALL
$ Direct Text Input for this subcase
BEGIN BULK
$ Direct Text Input for Bulk Data
PARAM POST 0
PARAM AUTOSPC YES
PARAM PRTMAXIM YES
NLPARM 1 10 AUTO 5 25 NO
$ Elements and Element Properties for region : HexwedTet
PSOLID 1 1 0
$ Pset: "HexwedTet" will be imported as: "psolid.1"
CHEXA 2793 1 14407 14420 14419 14406 14606 14627
      14626 14605
    
```

Group – RUN4-106NL-FA
 Input – Run4-106NL-fea.bdf
 Load -- RUN4-Loads
 Output – Run4-106NL-fea.xdb

```

CPENTA 95277 1 16149 12736 12733 16152 12576 12573
$ Elements and Element Properties for region : Sliding-Gaps
PGAP 2 0. 3.+7 500. 1.+7 .3 .3
      -1.
$ Pset: "Sliding-Gaps" will be imported as: "pgap.2"
CGAP 94612 2 102192 127702 2
CGAP 94613 2 102195 128013 2
CGAP 94614 2 102199 128016 2
CGAP 94615 2 102201 128015 2
    
```

RESULTANTS ABOUT ORIGIN OF SUPERELEMENT BASIC COORDINATE SYSTEM IN SUPERELEMENT BASIC SYSTEM COORDINATES.

SUBCASE/ DAREA ID	LOAD TYPE	T1	T2	T3	R1	R2	R3
0							
0	1	FX	0.000000E+00	----	----	0.000000E+00	0.000000E+00
		FY	----	-3.998594E+04	2.221206E+06	----	-9.220052E+05
		FZ	----	----	0.000000E+00	0.000000E+00	----
		MX	----	----	0.000000E+00	----	----
		MY	----	----	----	0.000000E+00	----
		MZ	----	----	----	----	0.000000E+00
	TOTALS		0.000000E+00	-3.998594E+04	0.000000E+00	2.221206E+06	0.000000E+00
							-9.220052E+05
1							

default_Fringe :
 Max 1.89-002 @Nd 5903

RUN #4-Results

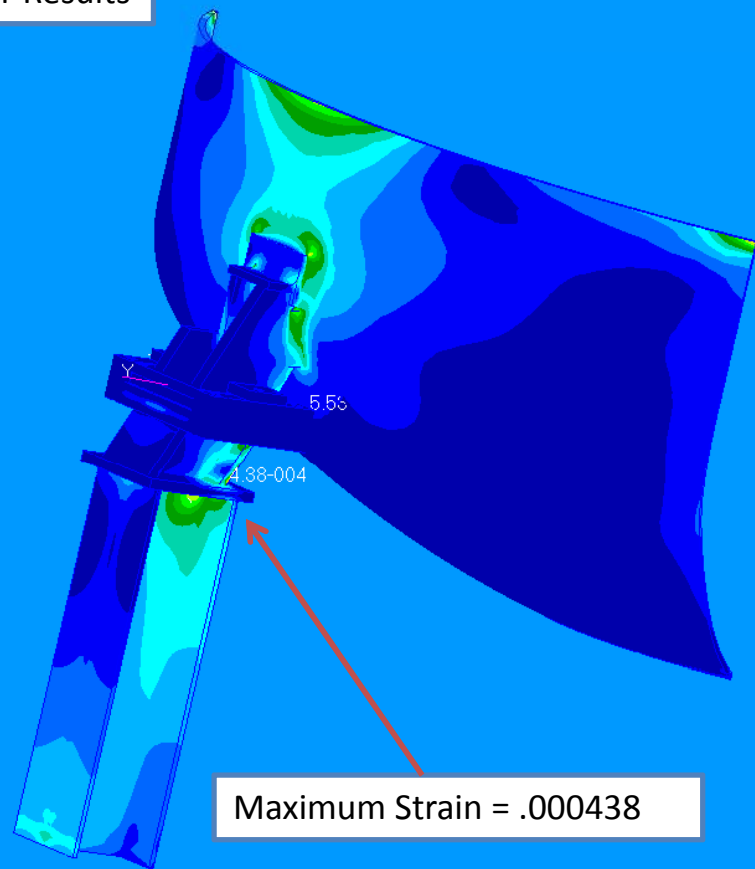
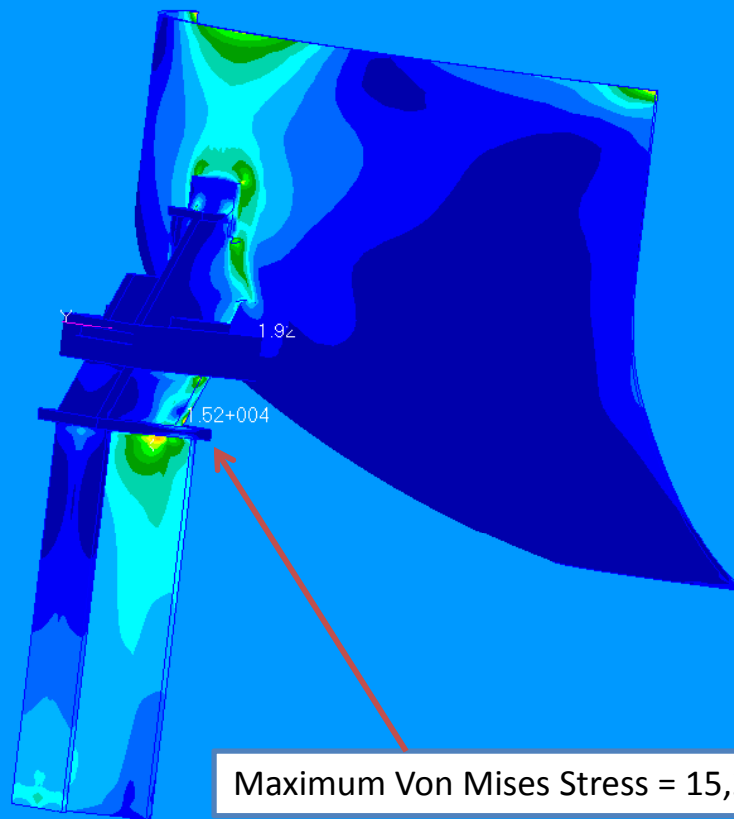

default_Fringe :
Max 4.38-004 @Nd 13863

Note: These Non Linear results are very close to those calculated in linear RUN #3. This is actually expected because non-linear GAP sliding is small (See following slides). This confirms that a linear analysis can be used as effectively as a non-linear analysis for solving this calculation.

MSC FEA 2010.1.2 64-Bit 06-Mar-12 14:22:22

Fringe: RUN4-Loads, A4:Non-linear: 100. % of Load, Stress Tensor, , von Mises, (NON-LAYERED)

MSC FEA 2010.1.2 64-Bit 06-Mar-12 14:34:18

Fringe: RUN4-Loads, A4:Non-linear: 100. % of Load, Strain Tensor, , (NON-LAYERED)

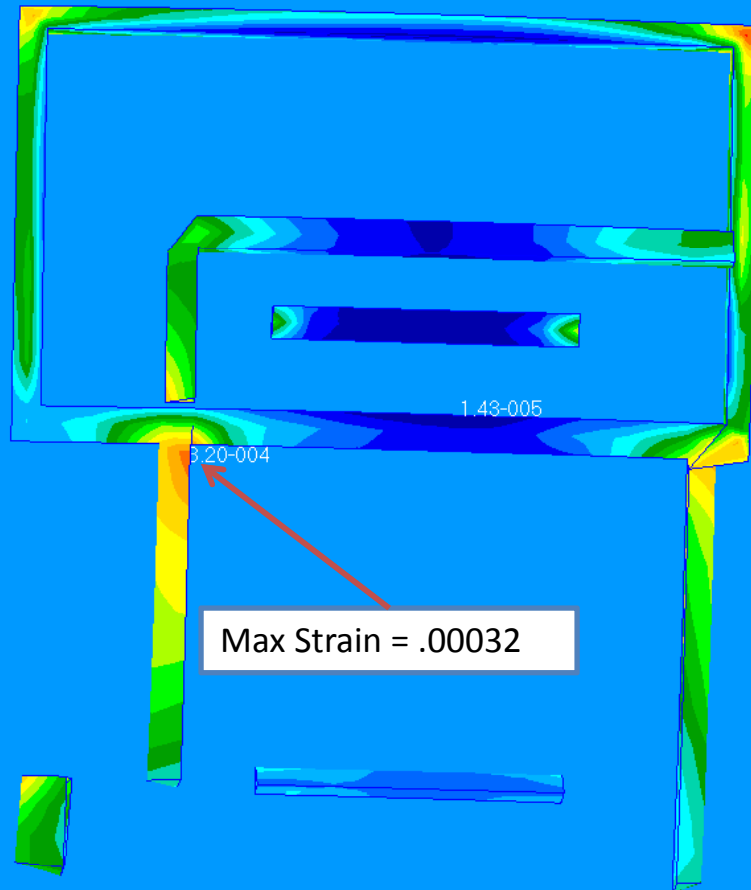

RUN #4-Results

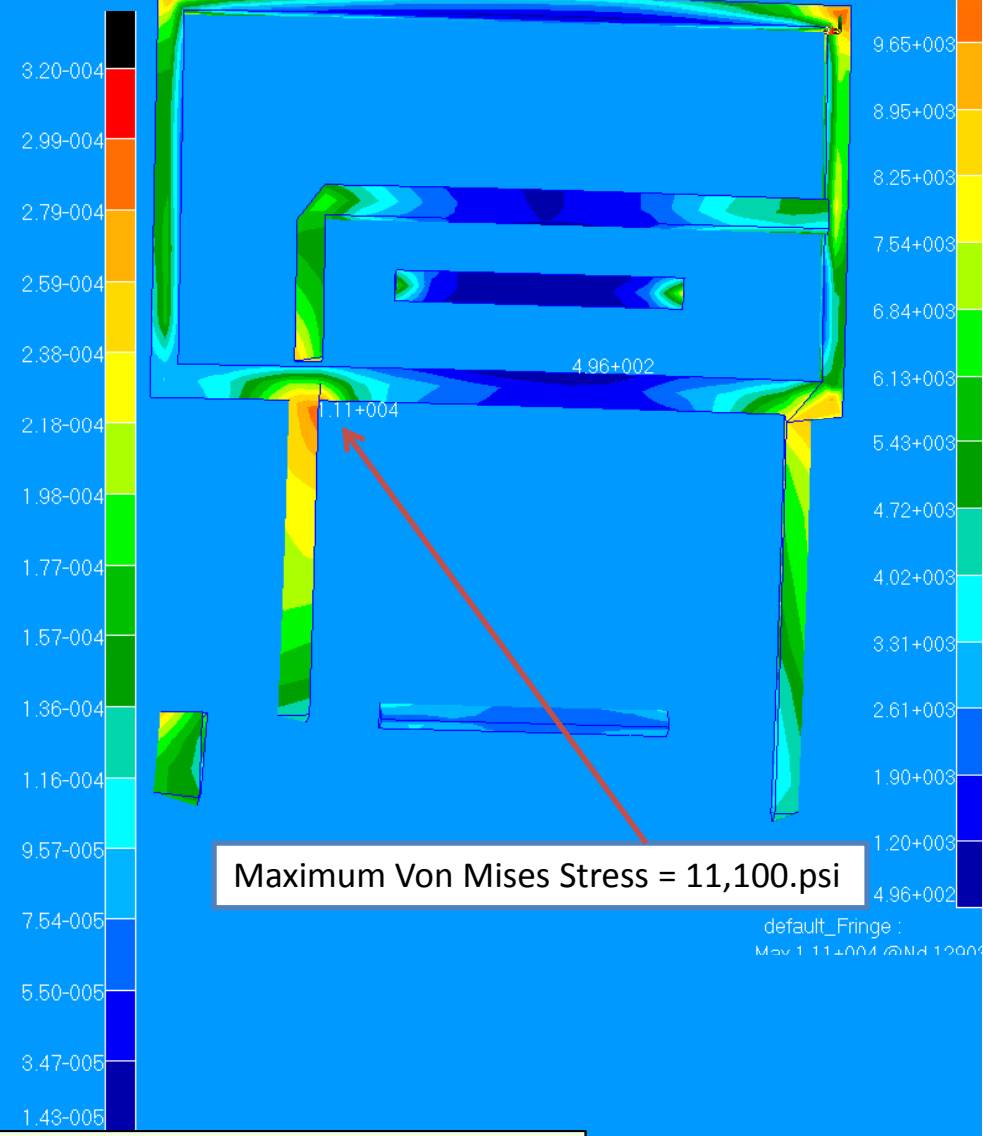

Please see Run #3 (Slide #16) results for comparison

RUN #4 – Load & Slip Results for Chair Slide Plate

Fringe: RUN4-Loads, A4:Non-linear: 100. % of Load, Gap Results, Force, Magnitude, At Center

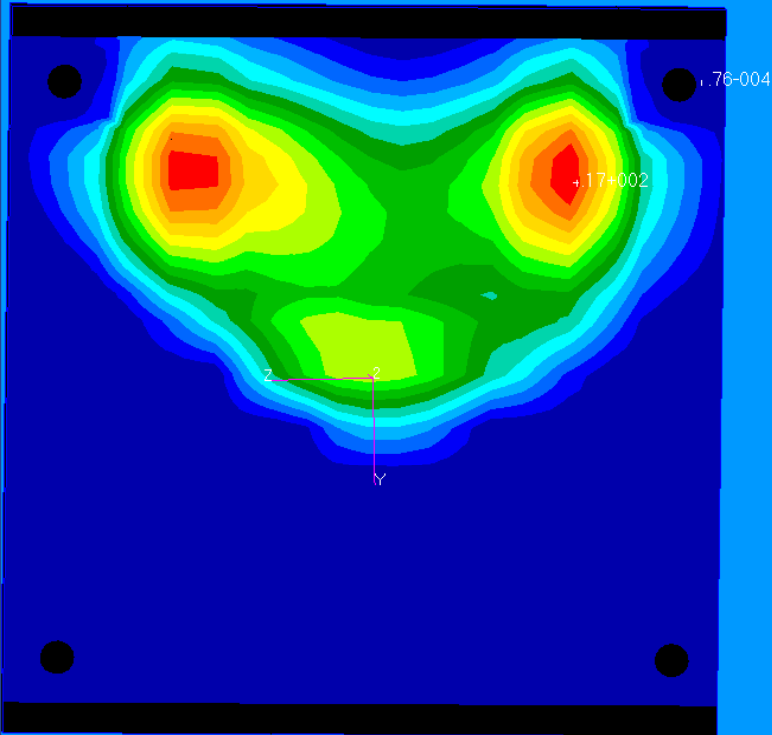

Gaps Load transfer distribution

Fringe: RUN4-Loads, A4:Non-linear: 100. % of Load, Gap Results, Slip, Magnitud

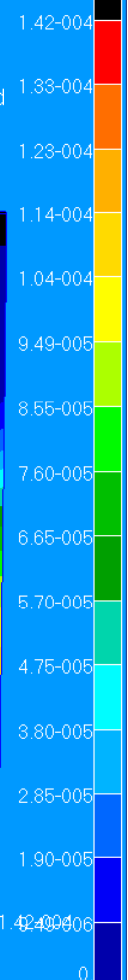
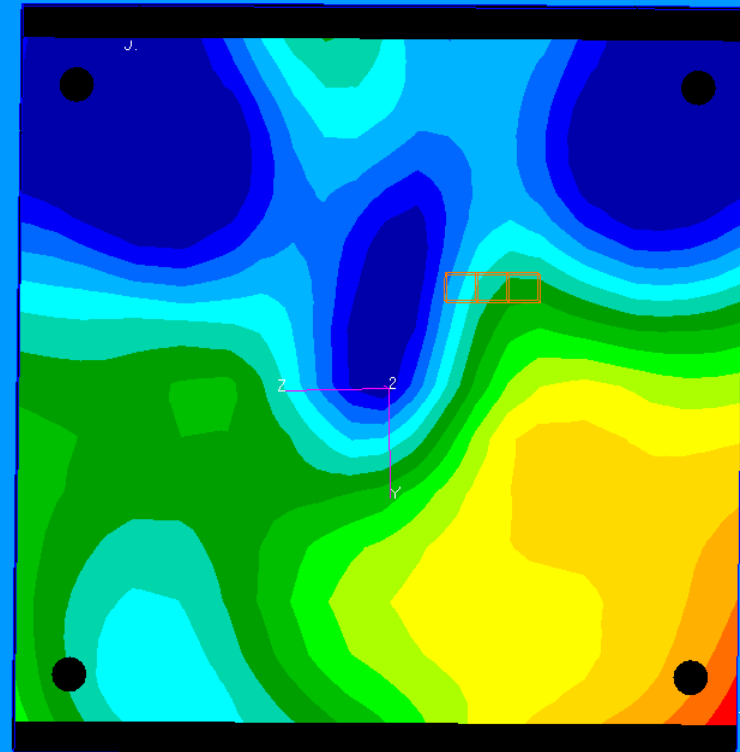

default_Fringe : Max 1.42e-04 @ND 131741

Gaps slipping distribution

Note : These results are based on the coefficient of friction = 0.3 for GAP "Y" and "Z" transverse directions

RUN #4 – GAP Contact Results

MSC FEA 2010.1.2 64-Bit 06-Mar-12 16:02:51

Fringe: RUN4-Loads, A4:Non-linear: 100. % of Load, Gap Results, Displacement, X Component, At Center

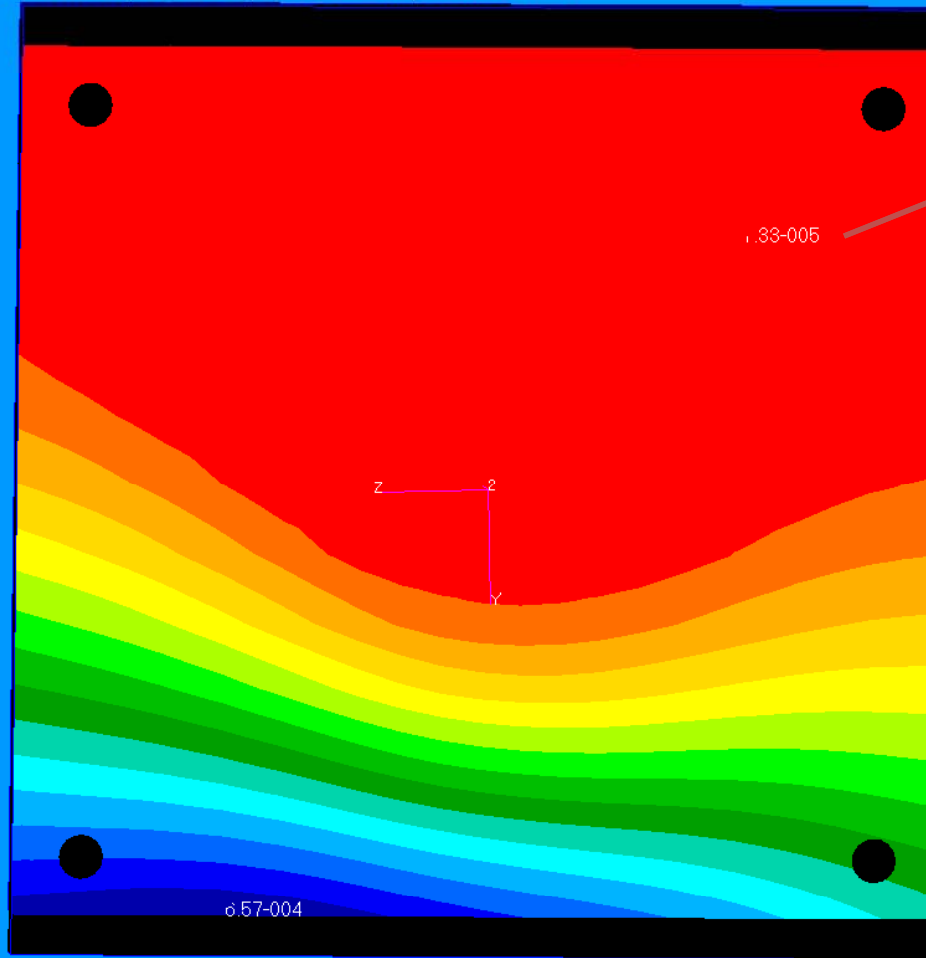

1.33-005

6.57-004



default_Fringe :
Max 1.33-005 @Nd 12919

Red area represents Gaps in contact (positive value X-direction of the Gaps)
other values are negative and represent Gaps opening.

Changes for RUN #5

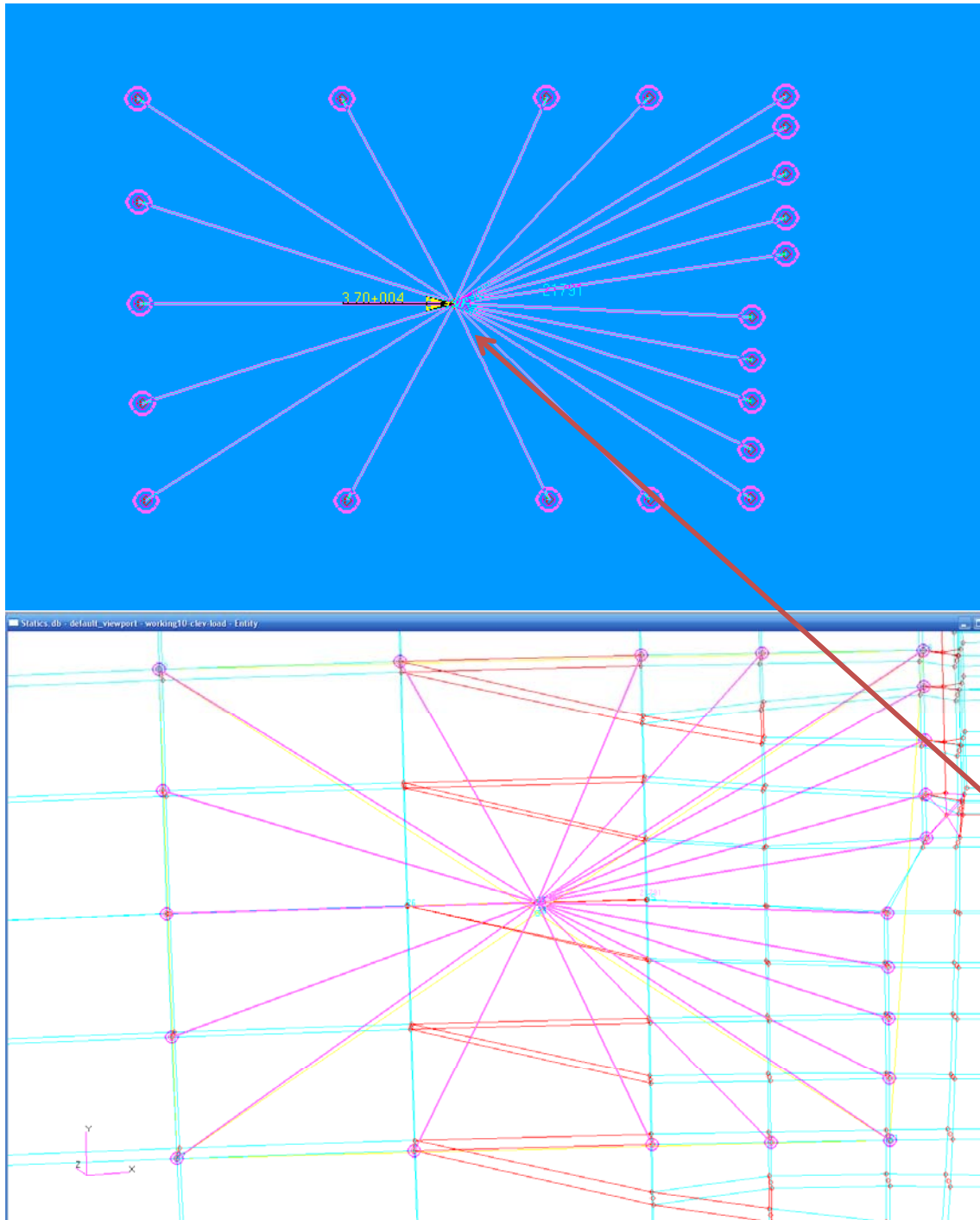

Introduction of the near-by Clevis force and its application is added to the Run #4 simulation. The VV-chair was redesigned because of the interference created by the new TF coil link connections to the VV. Therefore, the clevis is placed very close to the VV-chair structure. The slides on the left show this closeness and the RIGID BODY formation to simulate this condition. This body consists of the central node to which outside nodes are connected rigidly. Therefore, load applied at the central node distributes the force to the dependent nodes on the outside nodes which describe the maximum dimensions of the welded clevis. A force equal to 37,000. lbs is applied at the central node using cylindrical Coordinate System #1 in the Theta – direction.

Central node is independent.

RUN #5 - Configuration

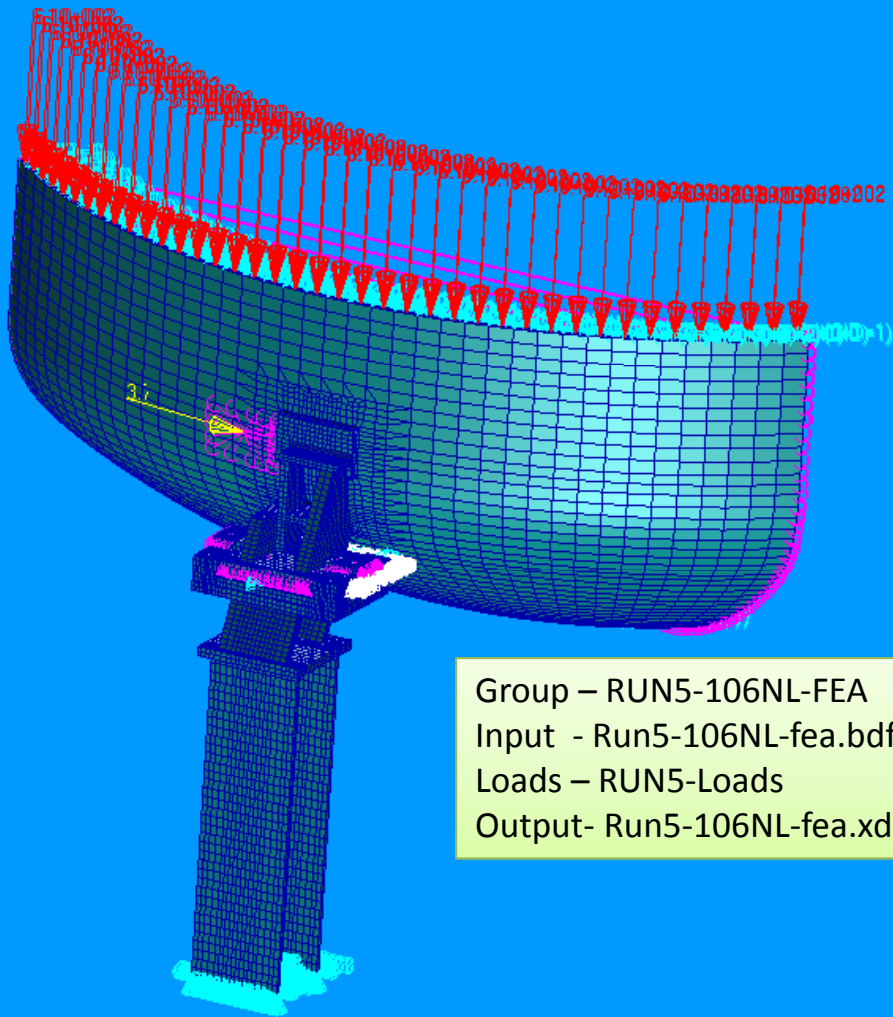

Group – RUN5-106NL-FEA
Input - Run5-106NL-fea.bdf
Loads – RUN5-Loads
Output- Run5-106NL-fea.xdb

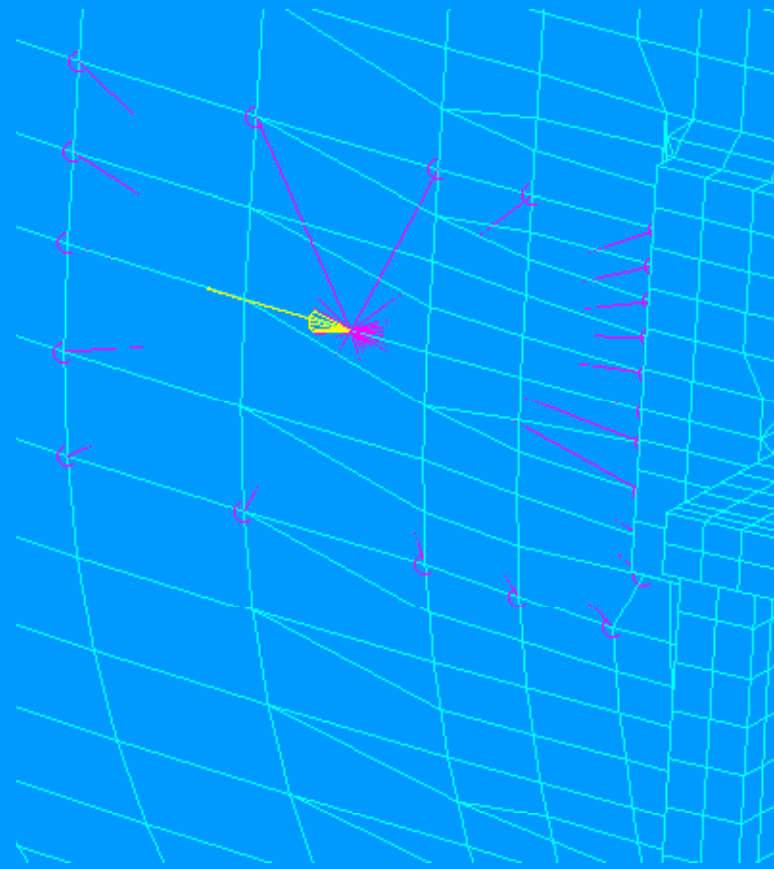

RUN #5 is a Sol 106 (Non-Linear) run with B.C. and Load from Run #4 and additional rigid body simulation for the Clevis pad which resists the 37,000. lbs shear load parallel to the VV surface. (Yellow arrow)

RUN #5 - Results

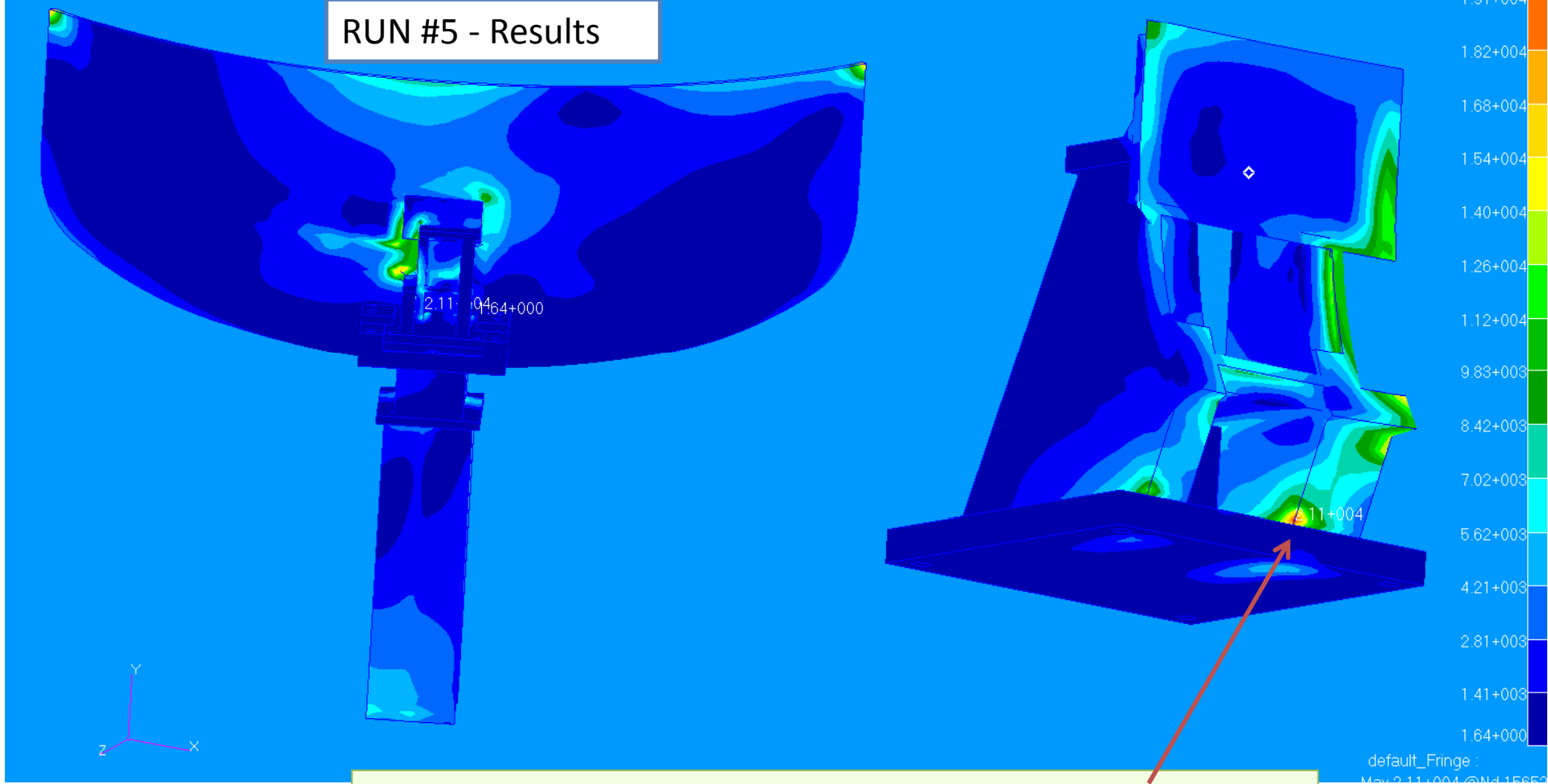

Maximum Von Mises Stresses around the VV-Chair connections = 21,100. psi at the Chair support. Welds seem to be O.K.

RUN #5 - Results

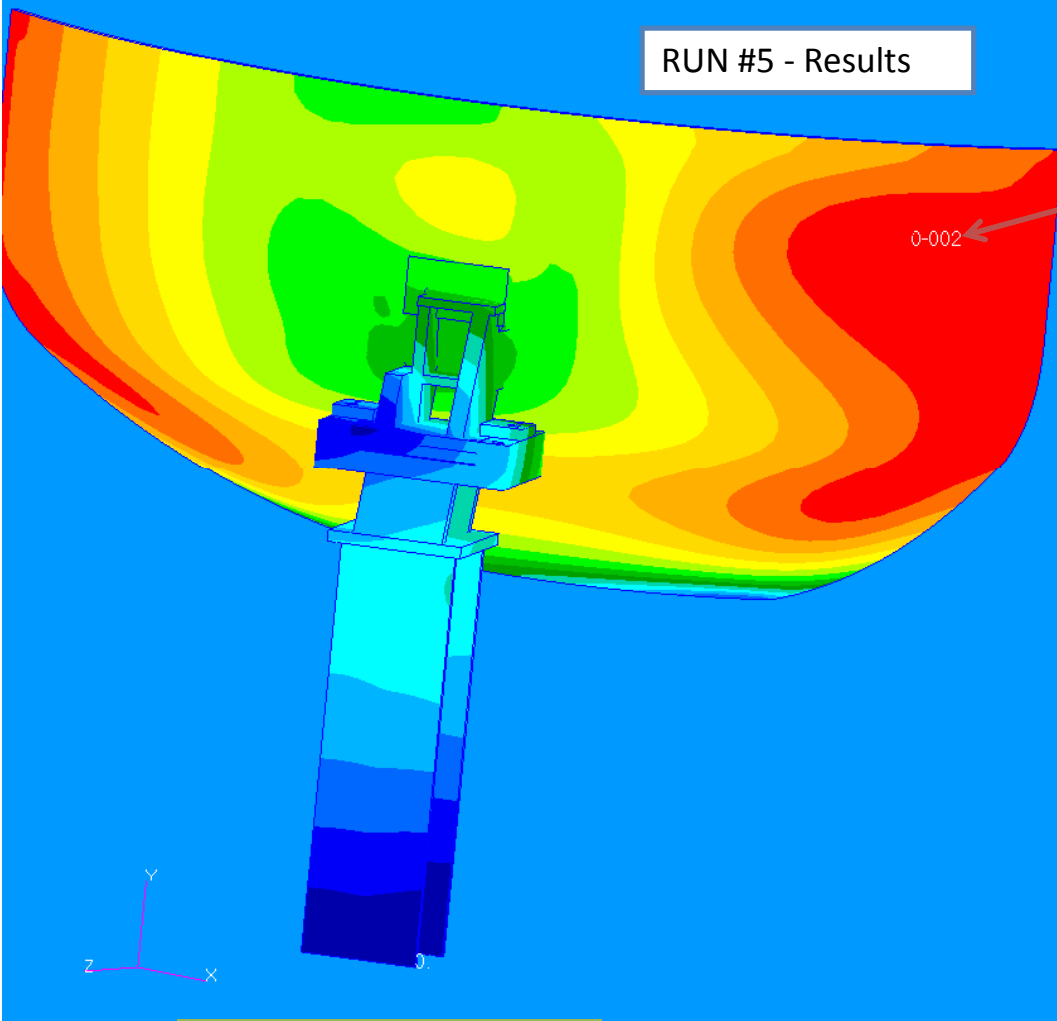

General displacements

Max Disp. = .02 inches

0-002

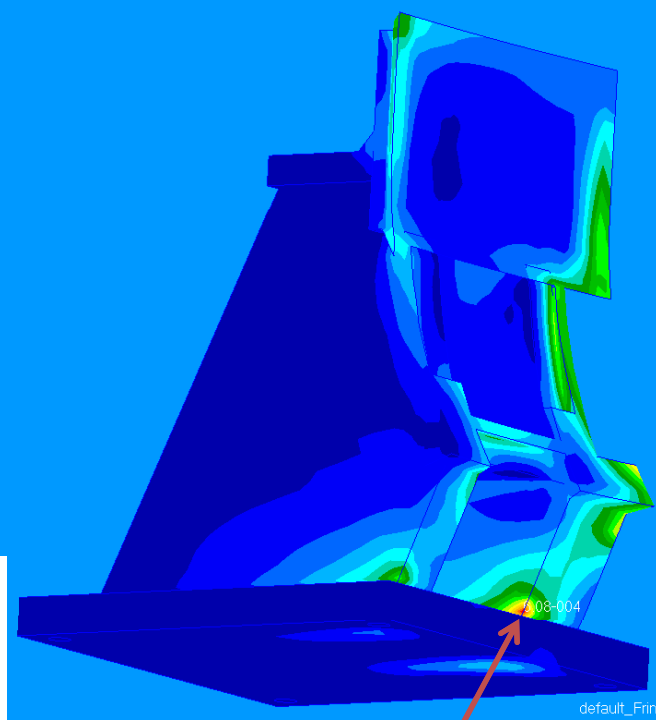

Maximum strain = .000608

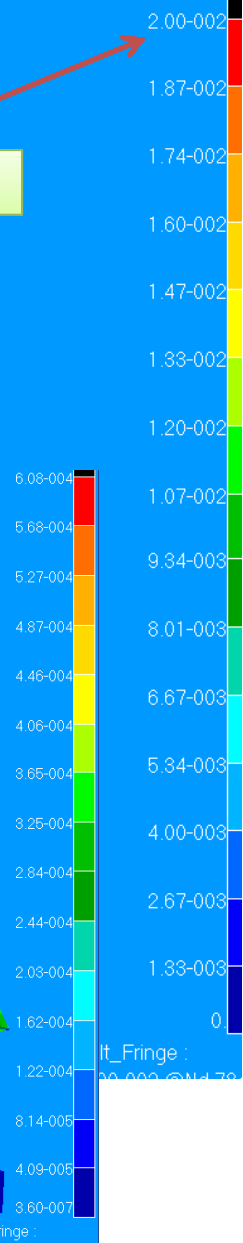

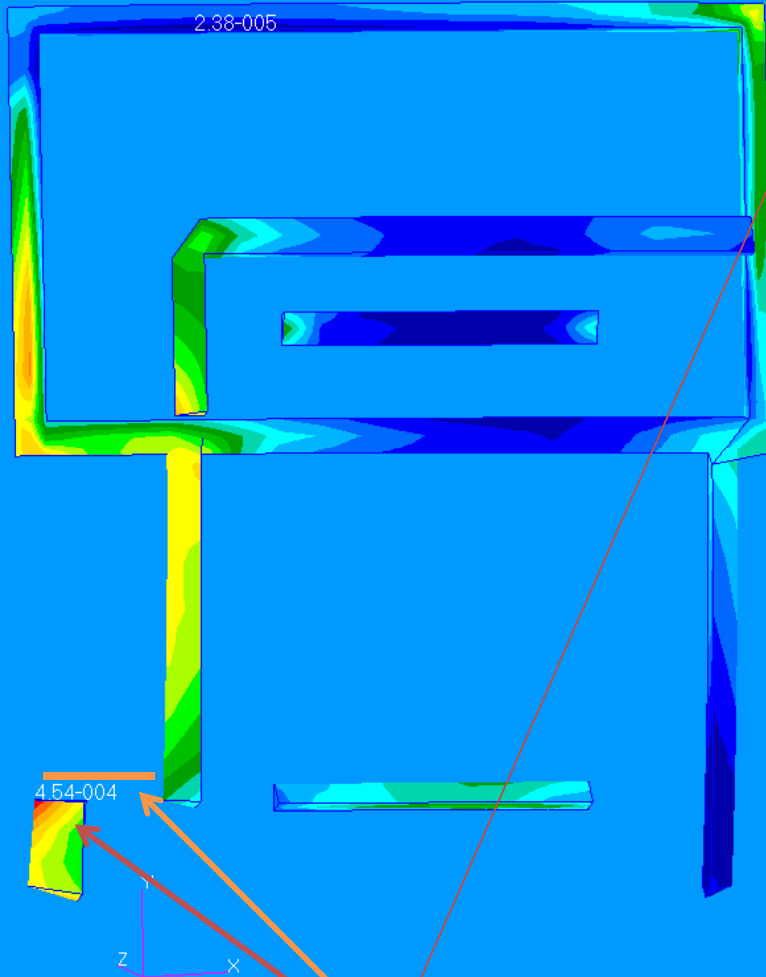

Maximum Strain = .00045

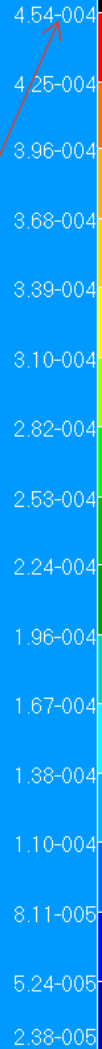

RUN #5 - Results

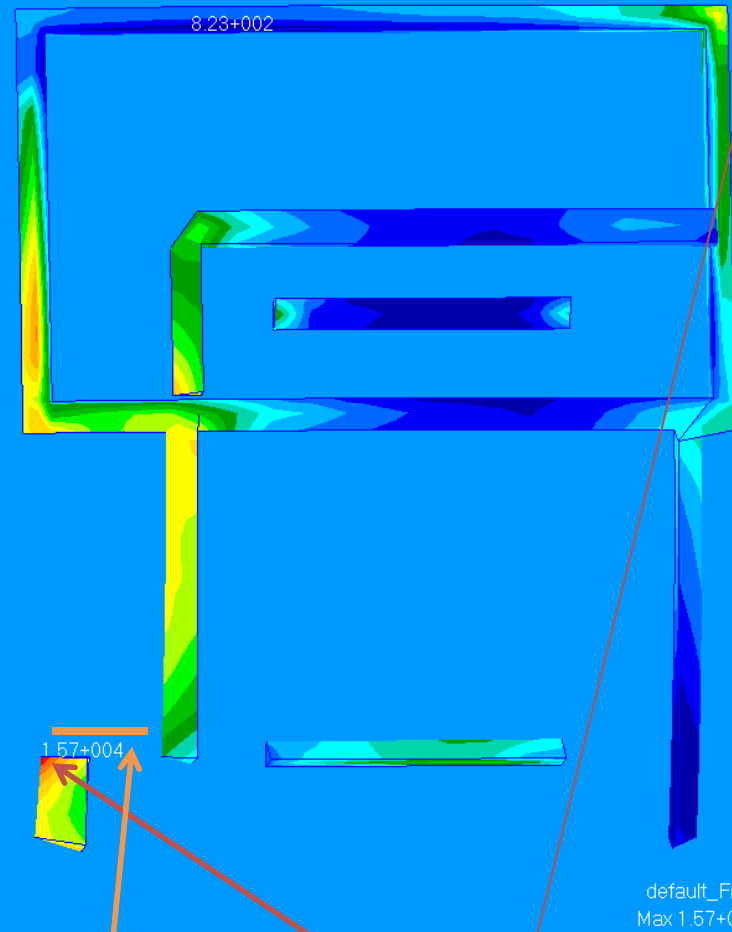

default_Fringe :
Max 1.57+004 @Nd 9450
Min 8.23+002 @Nd 16211

Maximum Von Mises Stress = 15,700. psi

Note: If this location is possible to weld, it should decrease the maximum stress and/or strain levels. Also see the welding slide below.

RUN #5 - Results

MSC FEA 2010.1.2 64-Bit 12-Mar-12 15:35:42

10.1.2 64-Bit 12-Mar-12 15:39:43

Fringe: SC1:RUN5-LOADS, A5:Non-linear: 100. % of Load, Gap Results, Force, Magnitude,

Fringe: SC1:RUN5-LOADS, A5:Non-linear: 100. % of Load, Gap Results, Slip, Magnitude, At

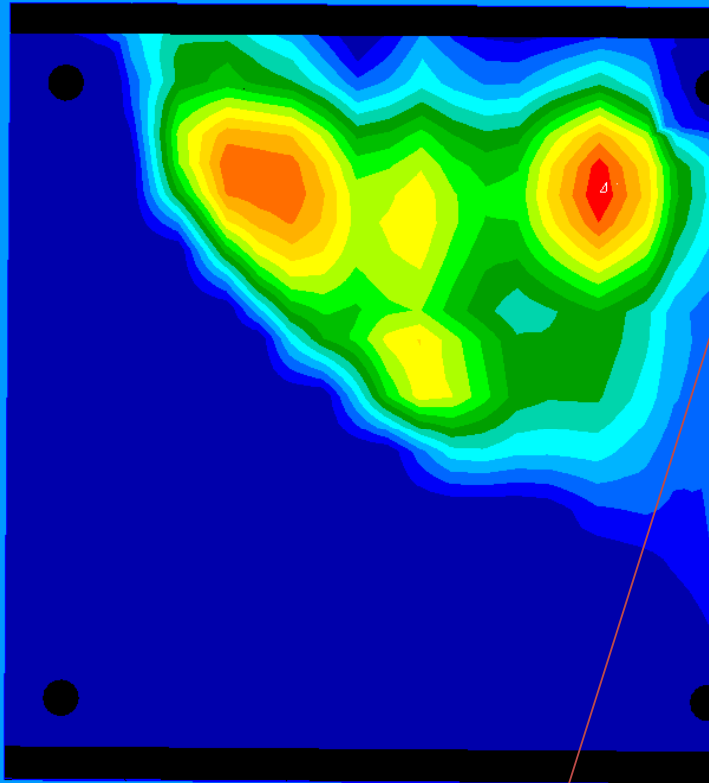

Maximum = 414. lbs

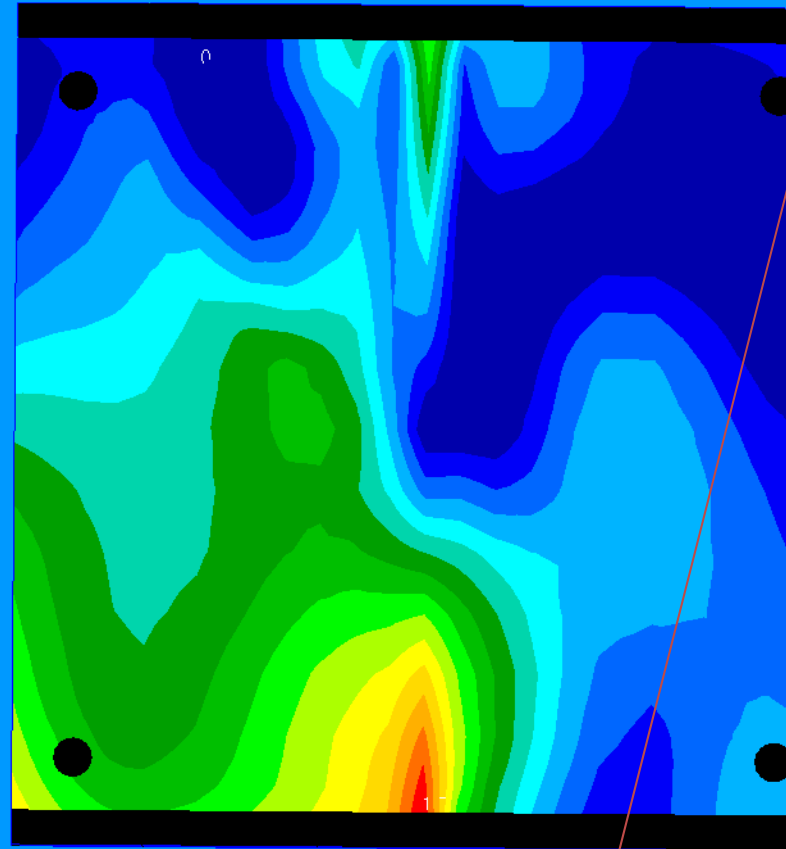
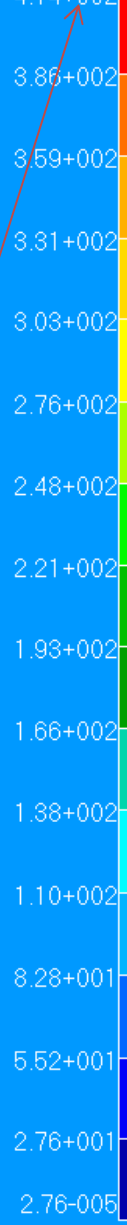

Maximum slide = .00018 inches

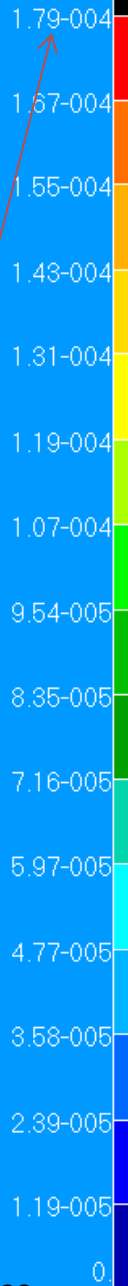

GAPS sliding profile. Compare with RUN #4 results (Slide 21).

Force distribution through the GAPS.
Note the difference with the Run #4 results (Slide 21). Forces tend to shift to the right, since, the 37,000. lbs force at the Clevis is in that direction.

Fringe :
+002 @Nd 12919
005 @Nd 131584

28
ge :
4 @Nd 130019

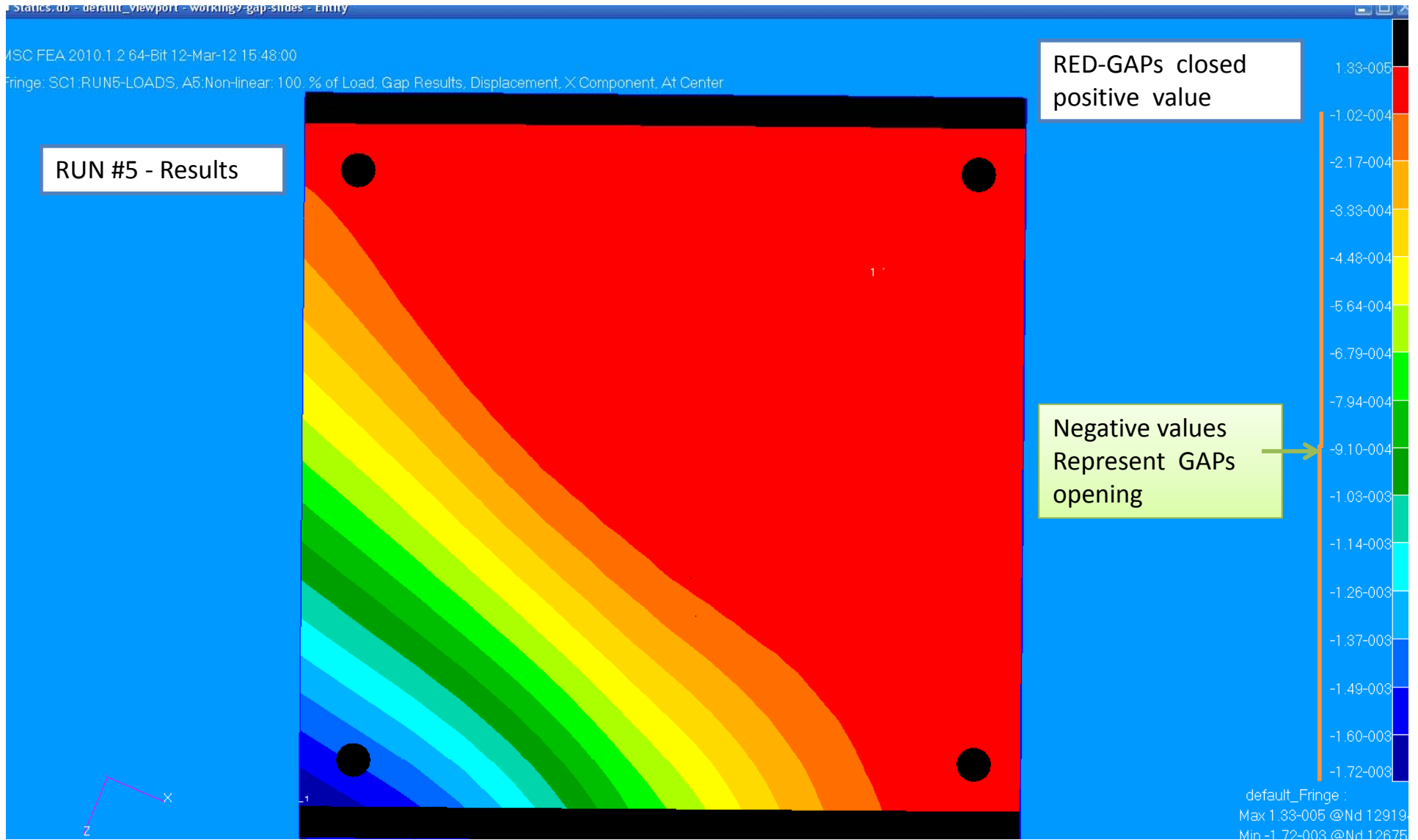

Coordinate 2 controls (defines) the used GAPs. The X-direction (normal to page) is the principal gap direction which defines if the gap is open or closed. Please see the ".bdf" input file for details. (Compare with Run #4 results shown on Slide 22.)

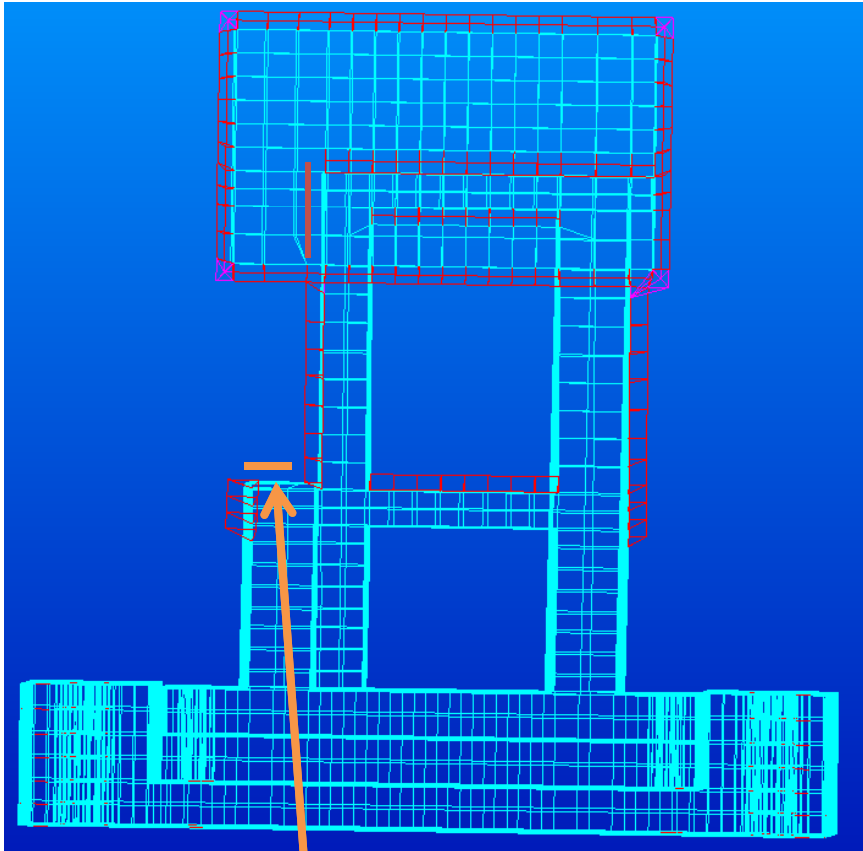

Area that would be extremely desirable to weld, but, may not be readily accessible

Red elements represent the actual welds

Welding scenario for the redesigned VV-Chair support

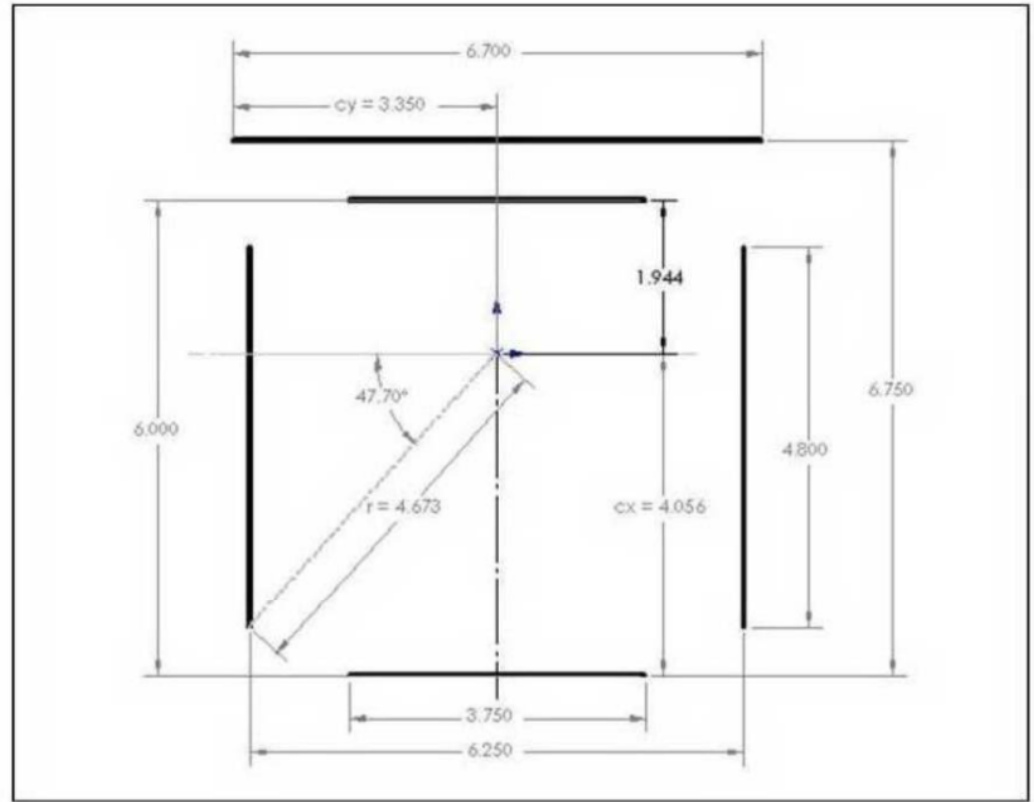
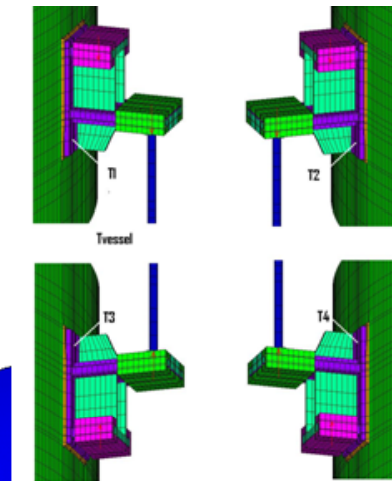
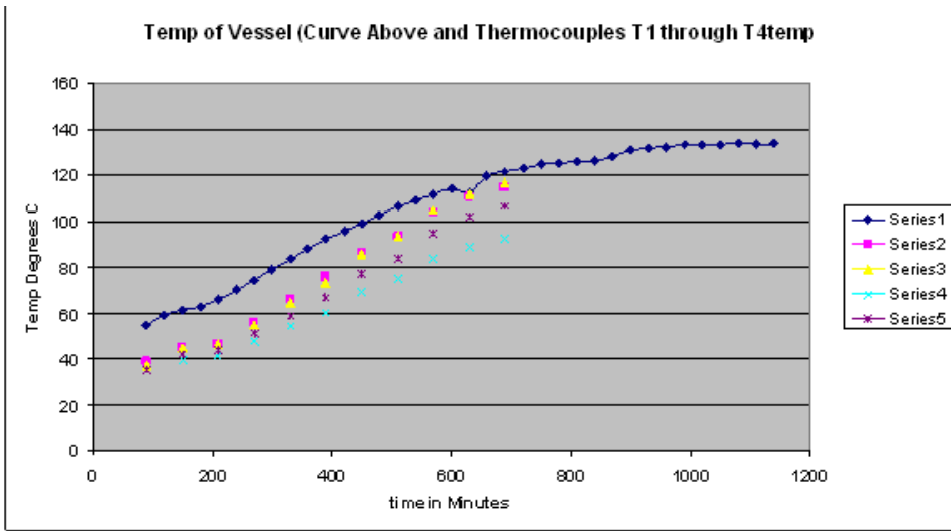

Figure 2 - Support Leg-to-Vessel Weld Dimensions

Original weld configuration – standard chair
Note: received from M. Smith (E-mail)



**RUN #6
Bakeout**

Conversion to degrees F

C	F
75.1	167.20
78.2	172.76
81.3	178.34
84.4	183.92
87.6	189.68
90.7	195.26
93.8	200.84
96.9	206.42
100.	212.0

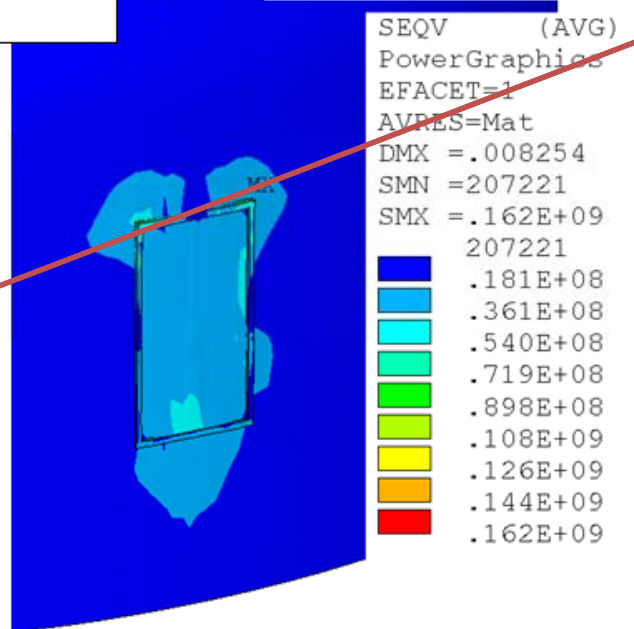
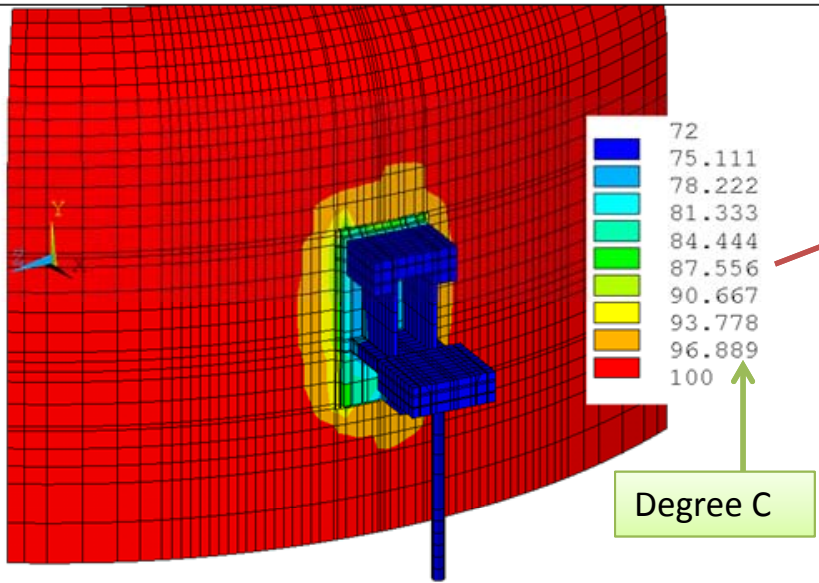

Use this for RUN #6

This data is taken from the previous PF 4 and 5 support hardware simulation. Similar temperature scenario exists in the area of contact between the VV and the main support Chair structure. This temperature data has to be converted to degrees F in order to be used in the present RUN #6 simulation.

RUN #6

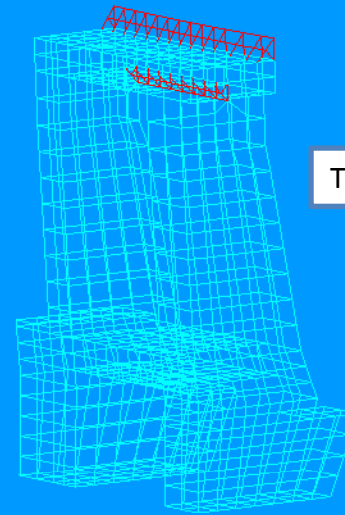
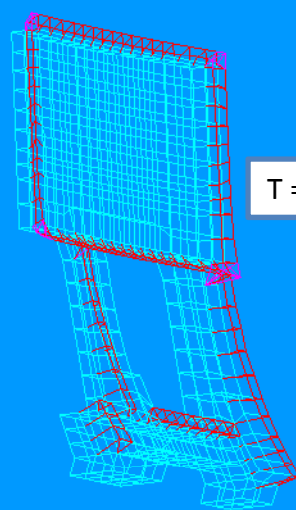
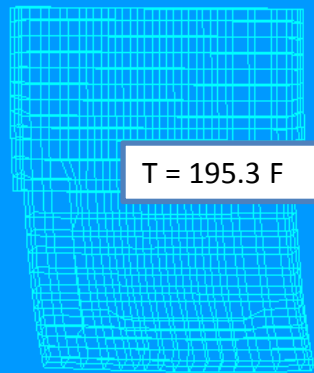
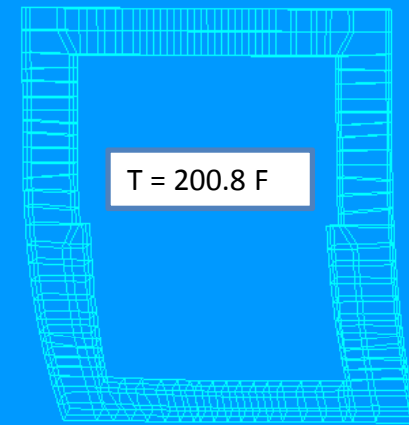
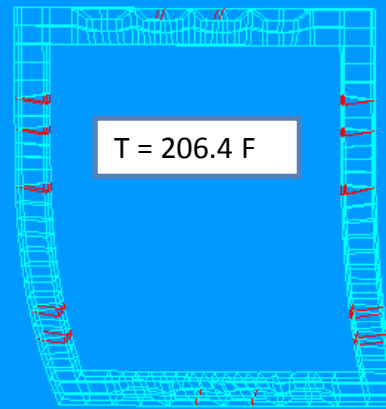
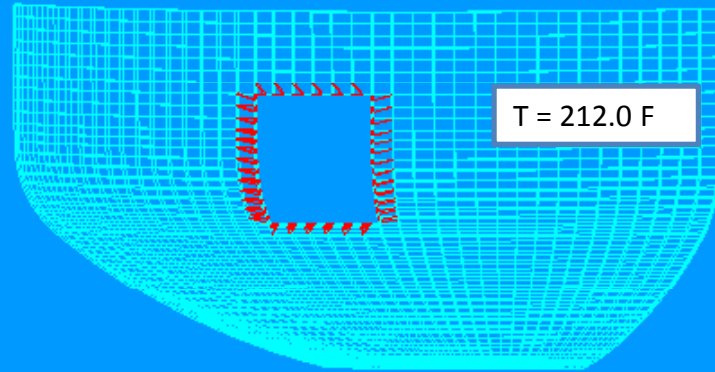

Applied temperature distribution according to the converted table from the previous slide. These groups are most critical in order to determine the VV bake out effects. This is a highly approximated temperature profile. The VV support structure is a very effective heat sink. Because of its total mass, the gradients are probably reasonable. If better simulation is necessary, then, a complete thermal analysis would be required to determine temperature at each nodal point (time consuming procedure).

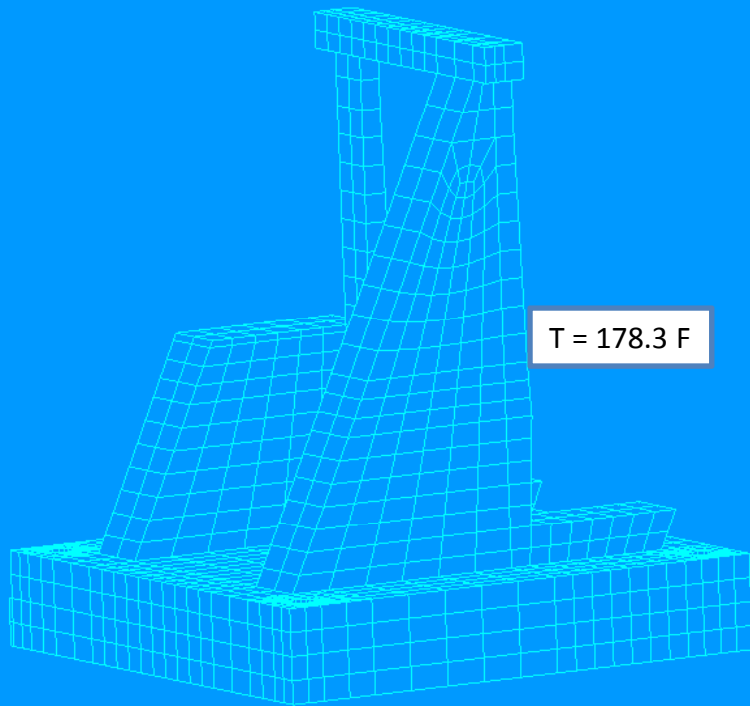

RUN #6

T 178.3 and 172.8 F
and 167.2 F

T = 162.0 F

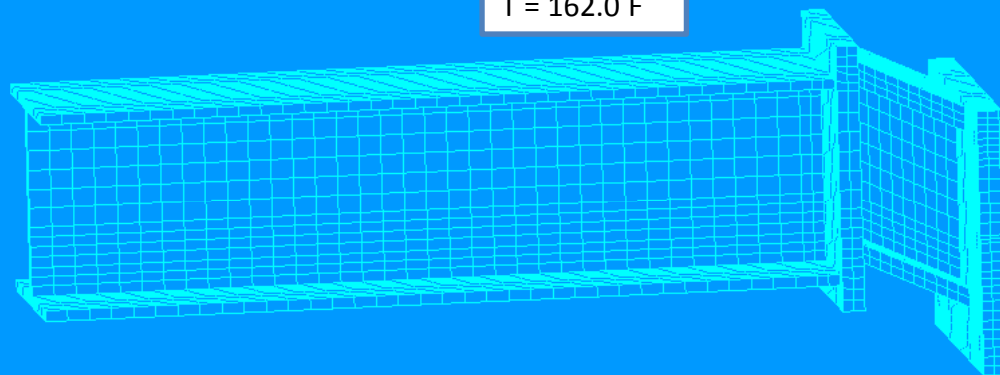

Please Note: The described temperature distribution is the result of the author's assumed interpolation.

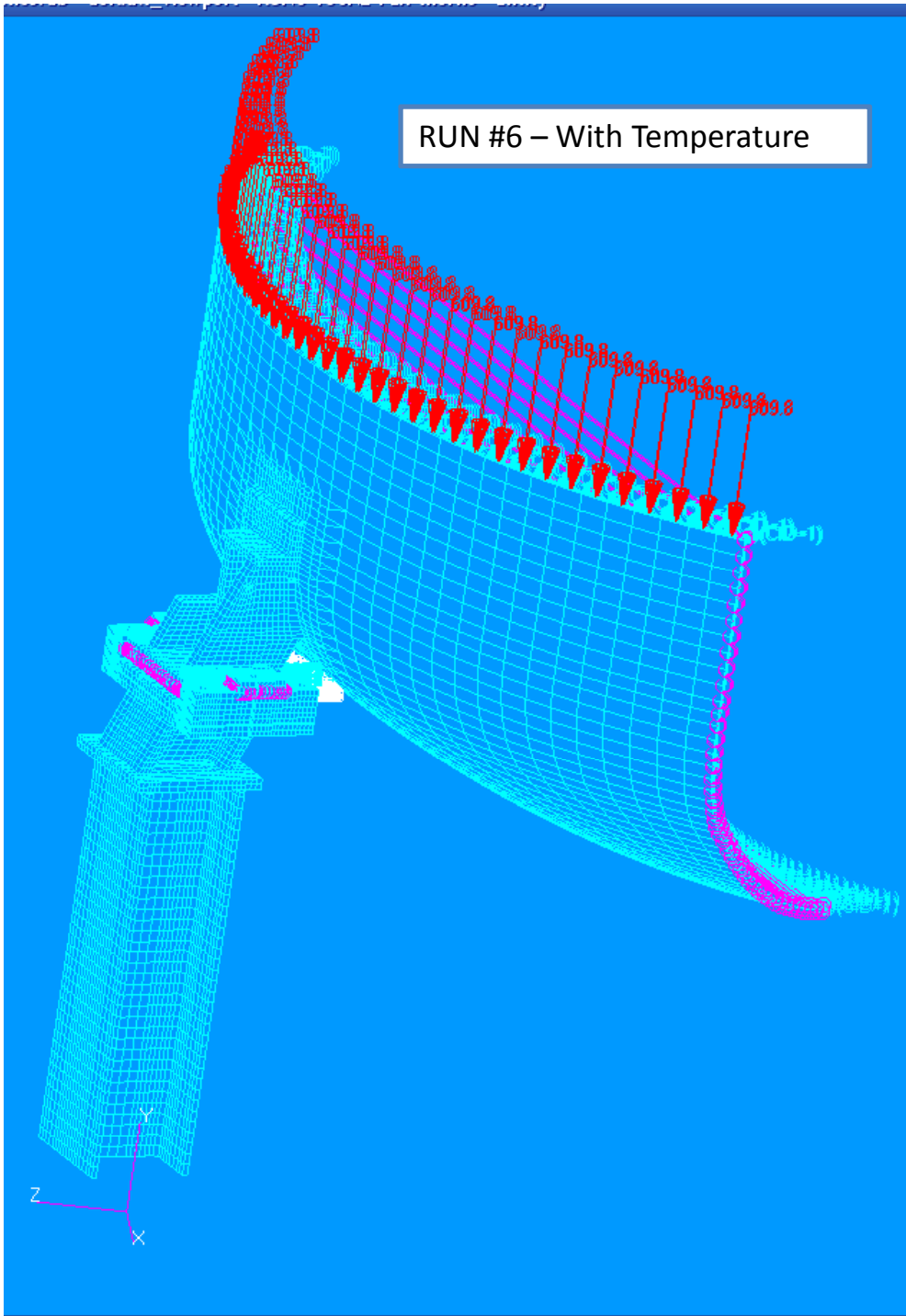

RUN #6 – With Temperature

```

$ Nonlinear Static Analysis, Database
SOL 106
CEND
TITLE = MSC.NASTRAN JOB CREATED ON 17-FEB-12 AT 08:48:38
ECHO = NONE
MPC = 20134
TEMPERATURE(INITIAL) = 10
SUBCASE 1
  TITLE=106 with THERMO
  SUBTITLE=RUN6-Loads
  NLPARM = 1
  SPC = 2
  LOAD = 12
  TEMPERATURE(LOAD) = 2
  DISPLACEMENT(SORT1,REAL)=ALL
  SPCFORCES(SORT1,REAL)=ALL
  STRAIN(SORT1,REAL,VONMISES,STRCUR,BILIN)=ALL
  STRESS(SORT1,REAL,VONMISES,BILIN)=ALL
$ Direct Text Input for this Subcase
BEGIN BULK
$ Direct Text Input for Bulk Data
PARAM POST 0
PARAM AUTOSPC YES
PARAM PRTMAXIM YES
NLPARM 1 10 AUTO 5 25 NO
$ Elements and Element Properties for region : HexwedTet
  
```

From the "RUN6.bdf" file

Group – RUN6-106HL-FEA-thermo
 Input -- RUN6-NL-THLoads.bdf
 Loads -- RUN6-Loads
 Output – RUN6-NL-THLoads.xdb

RUN #6 Loads formulation is as follows:

 Mechanical loads and B.C. are identical to those applied in RUN #4, plus the described temperature distribution scenarios on the previous slides.

MSC FEA 2010.1.2 64-Bit 16-Mar-12 14:47:52

Fringe: RUN6-Loads, A7:Non-linear: 100. % of Load, Strain Tensor, . .

MSC FEA 2010.1.2 64-Bit 16-Mar-12 14:44:43

Fringe: RUN6-Loads, A7:Non-linear: 100. % of Load, Stress Tensor, . von Mises, (NON-LAYERED)

RUN #6 - Results

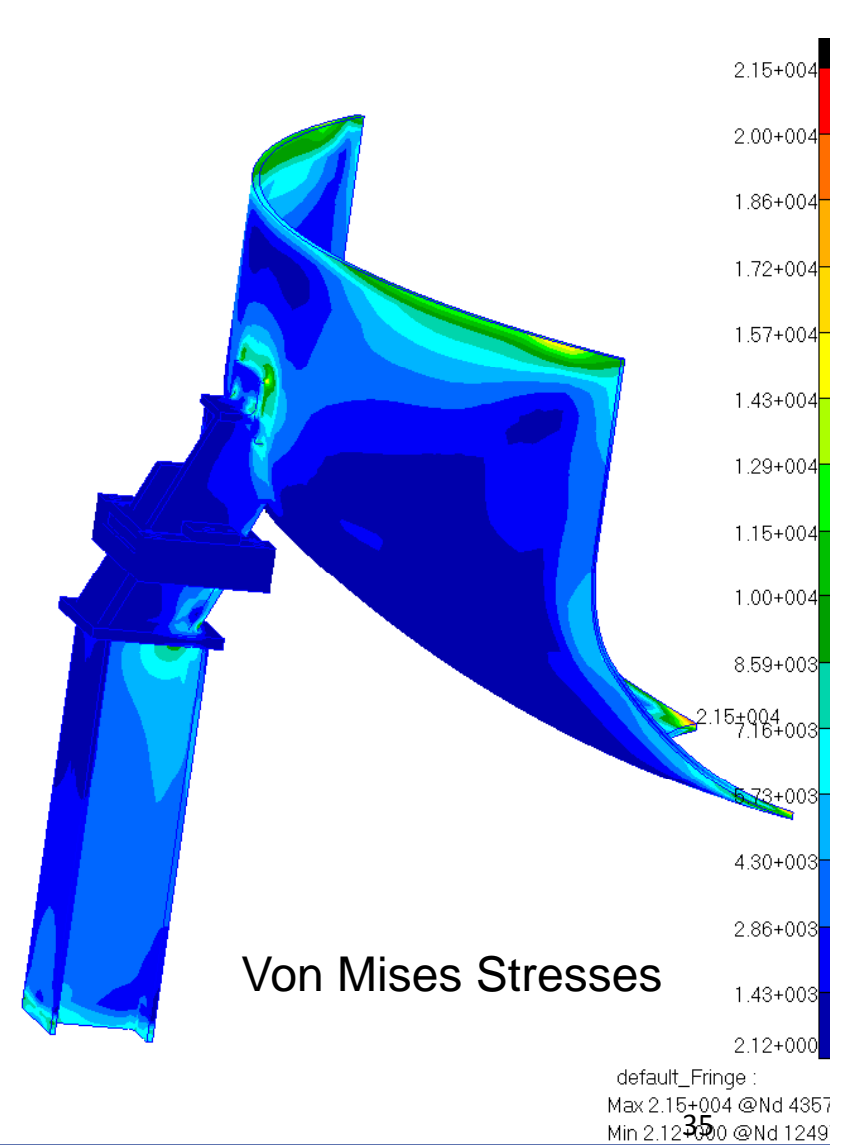
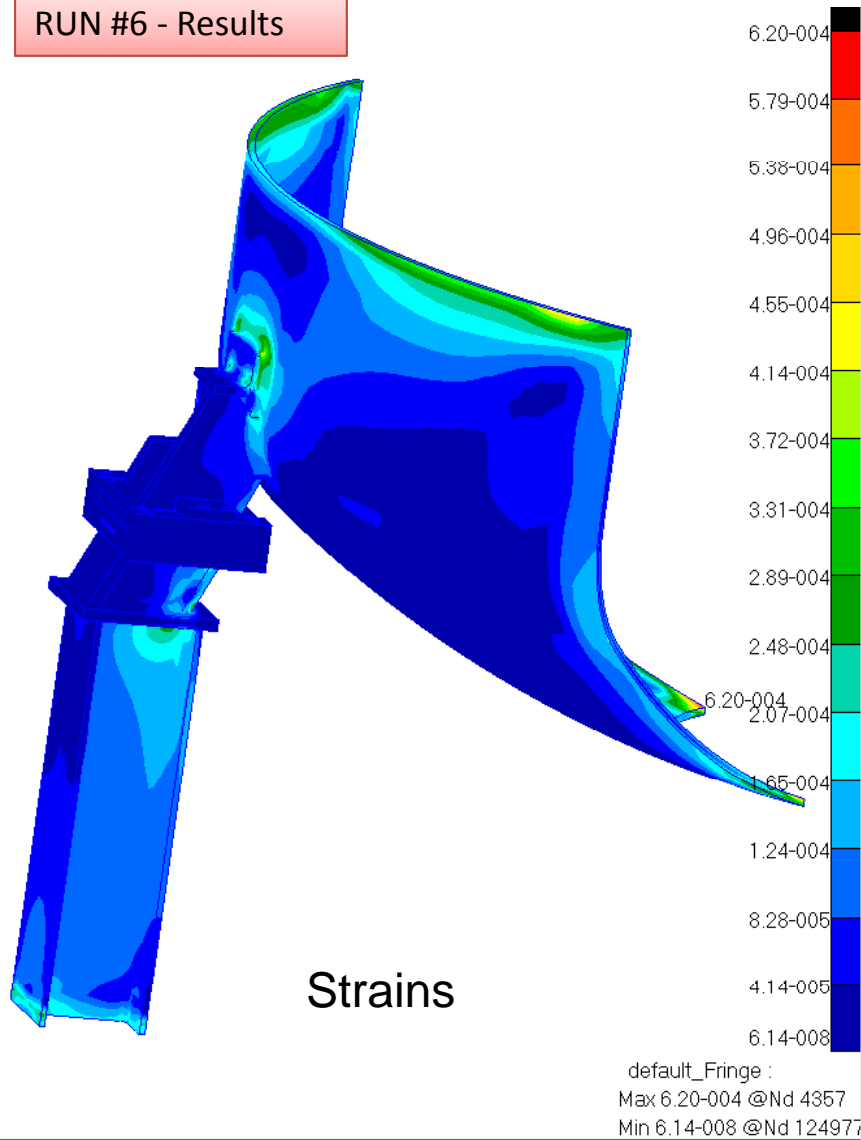

RUN #6 - Results

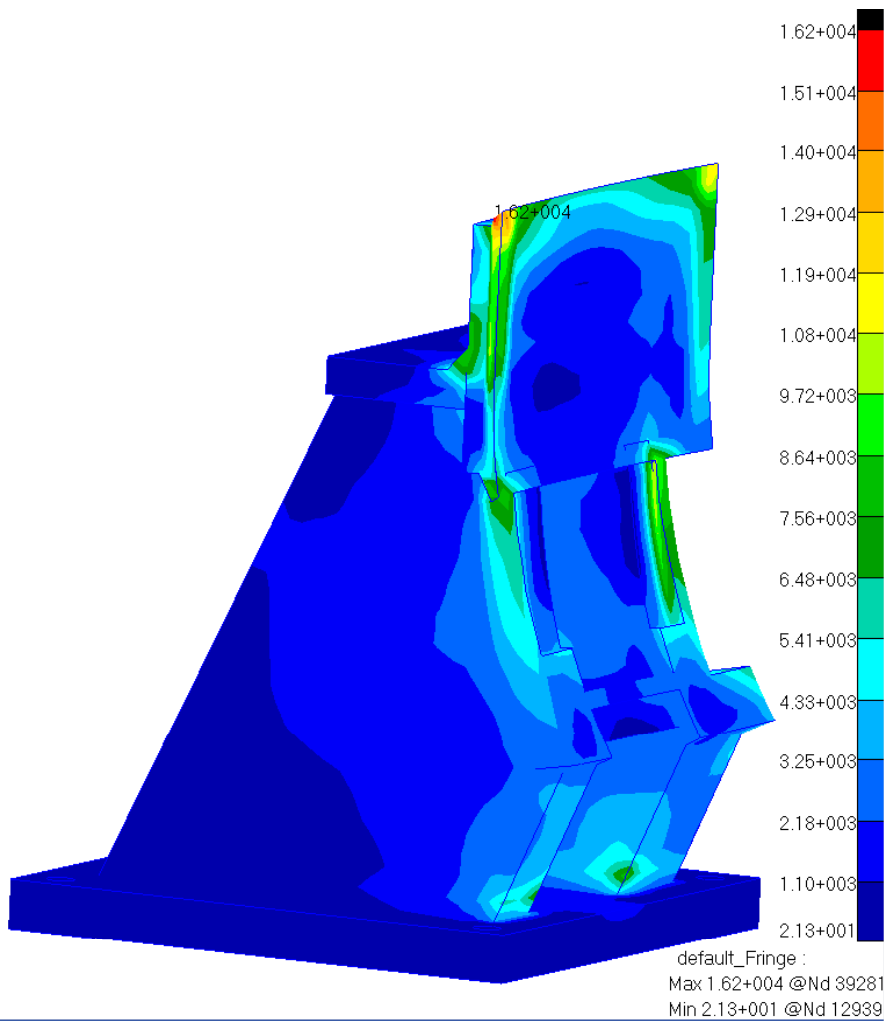

Von Mises Stresses

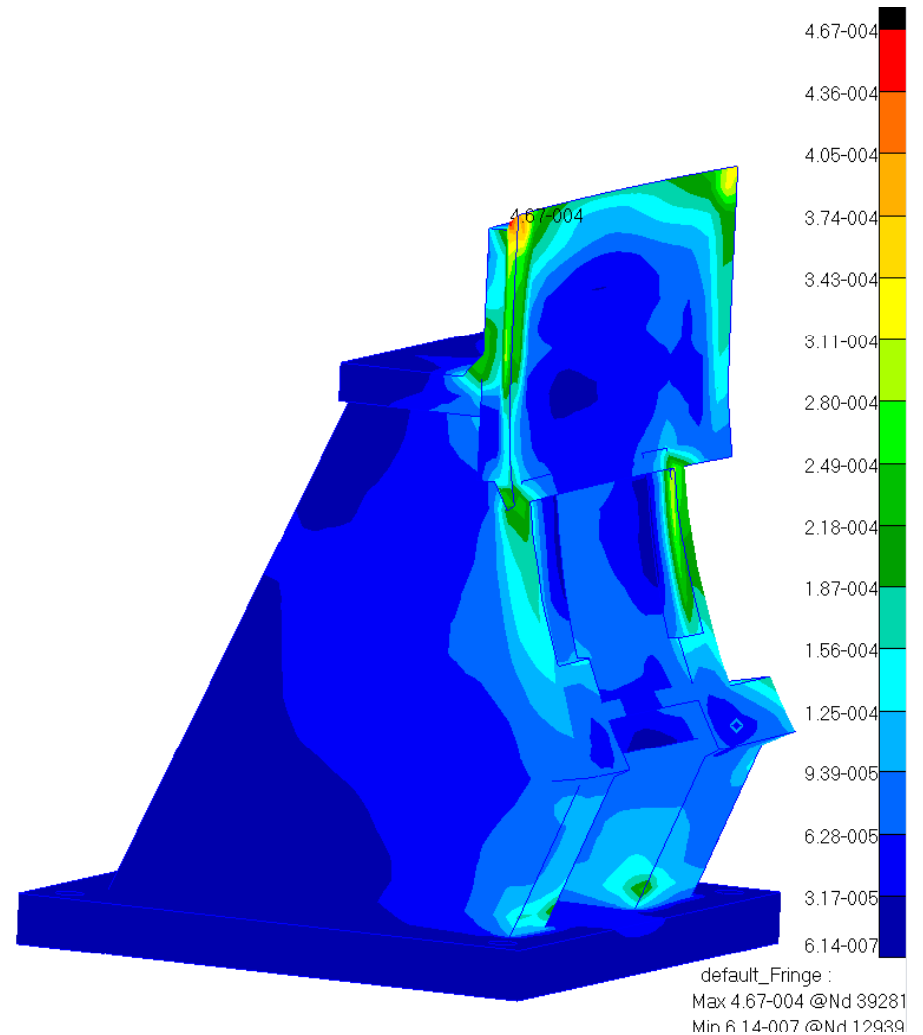

Strains

RUN #6 - Results

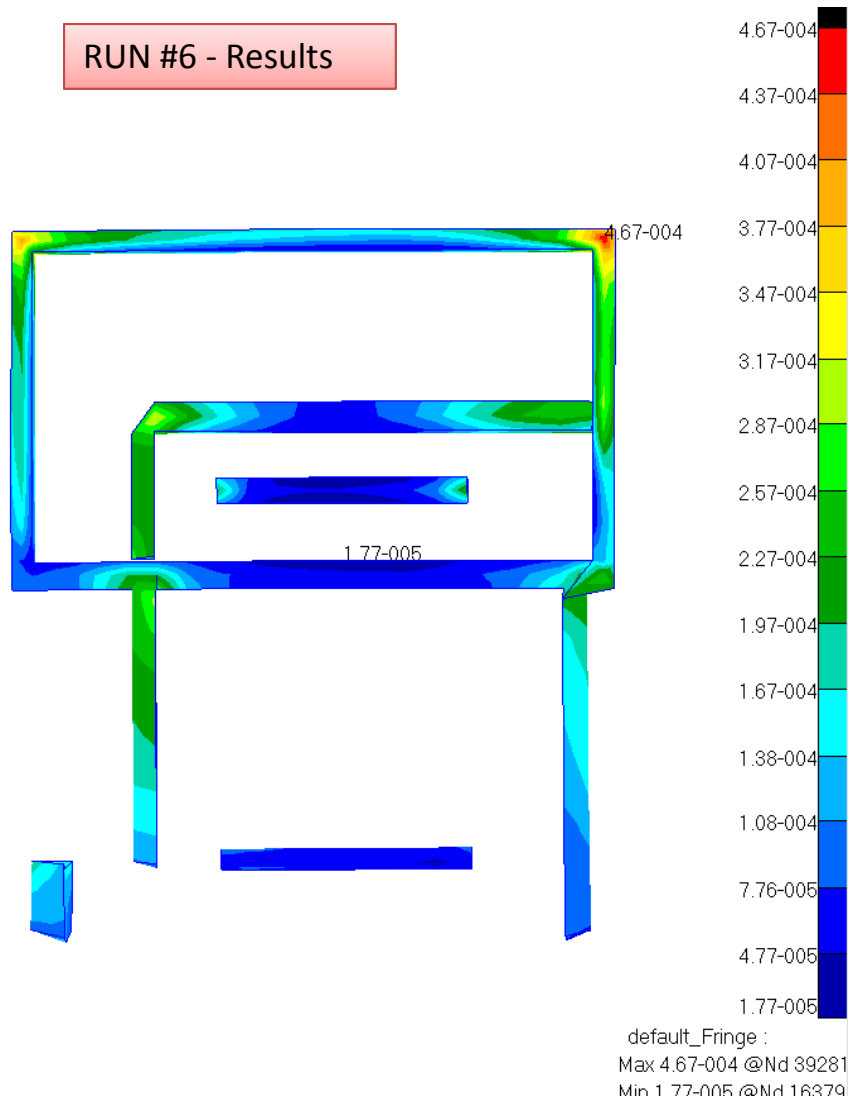

Strains

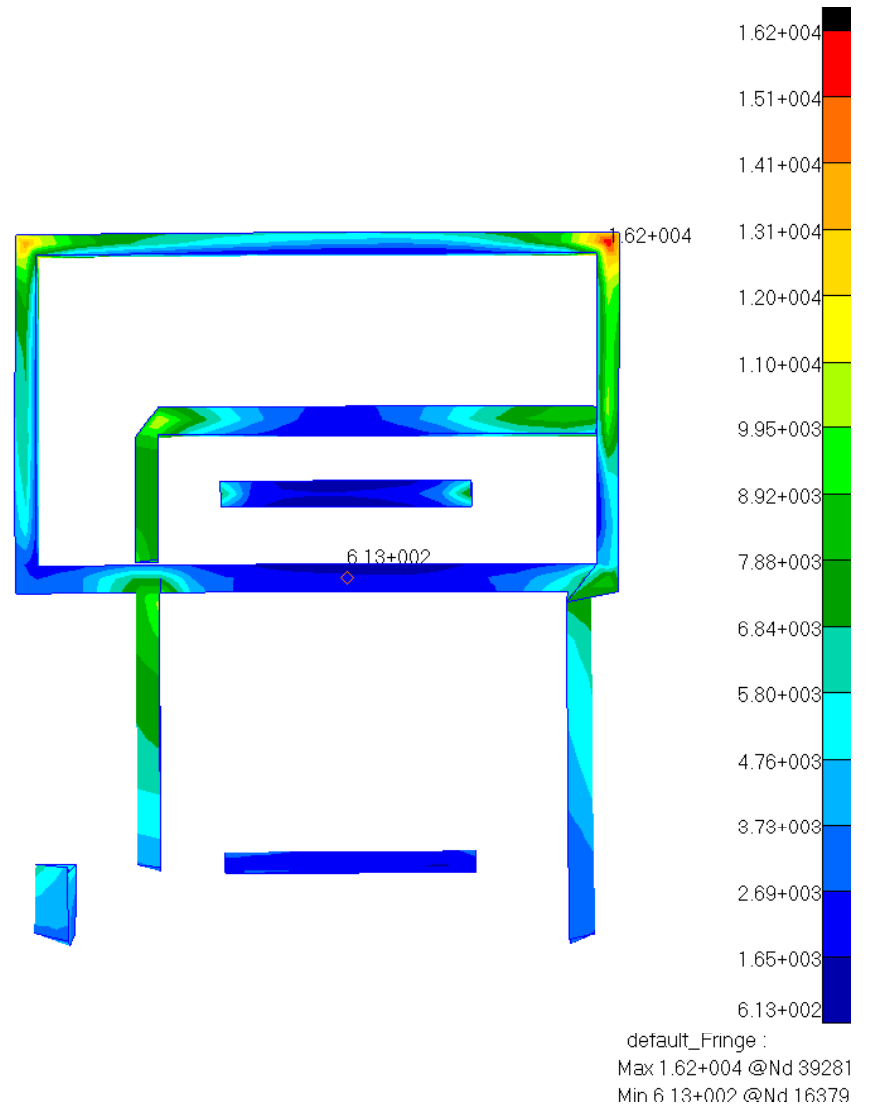

Von Mises Stresses

MSC FEA 2010.1.2 64-Bit 16-Mar-12 15:37:23

RUN #6 - Results

Fringe: RUN6-Loads, A7:Non-linear: 100. % of Load, Gap Results, f

s, Force, X Component, At Center

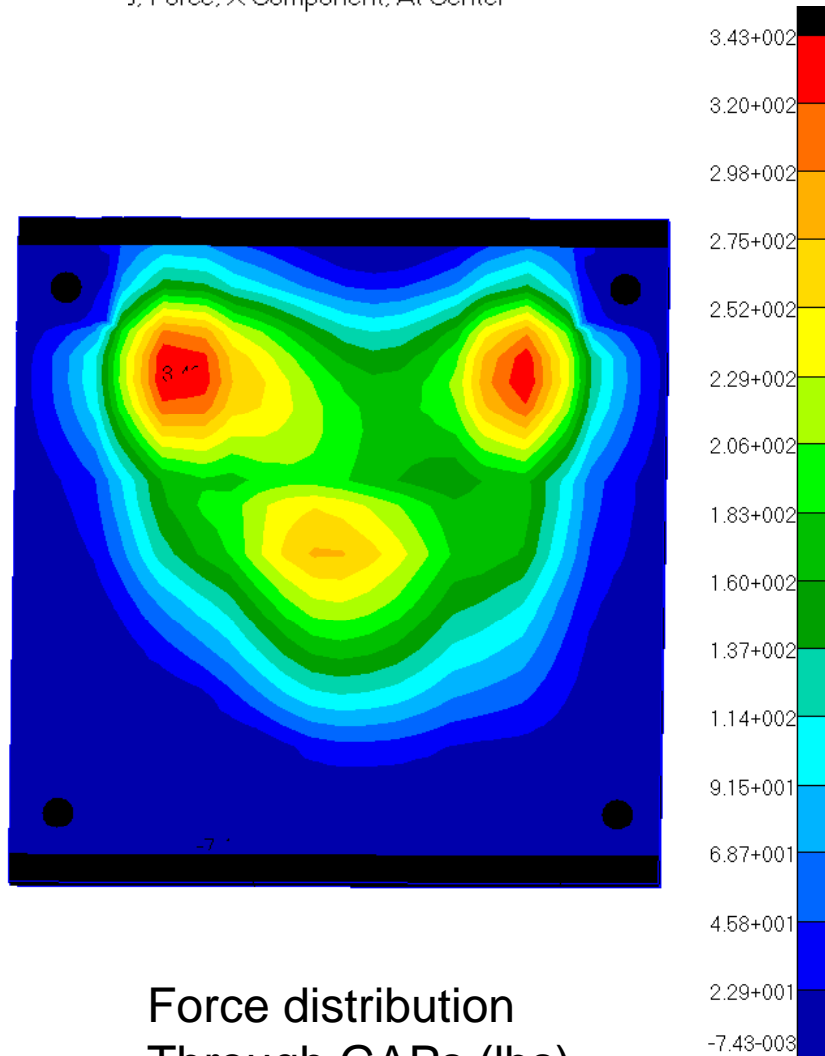

Force distribution
Through GAPS (lbs)

default_Fringe :
Max 3.43+002 @Nd 128121
Min -7.43-003 @Nd 128752

MSC FEA 2010.1.2 64-Bit 16-Mar-12 15:28:41

Fringe: RUN6-Loads, A7:Non-linear: 100. % of Load, Gap Results,

s, Displacement, X Component, At Center

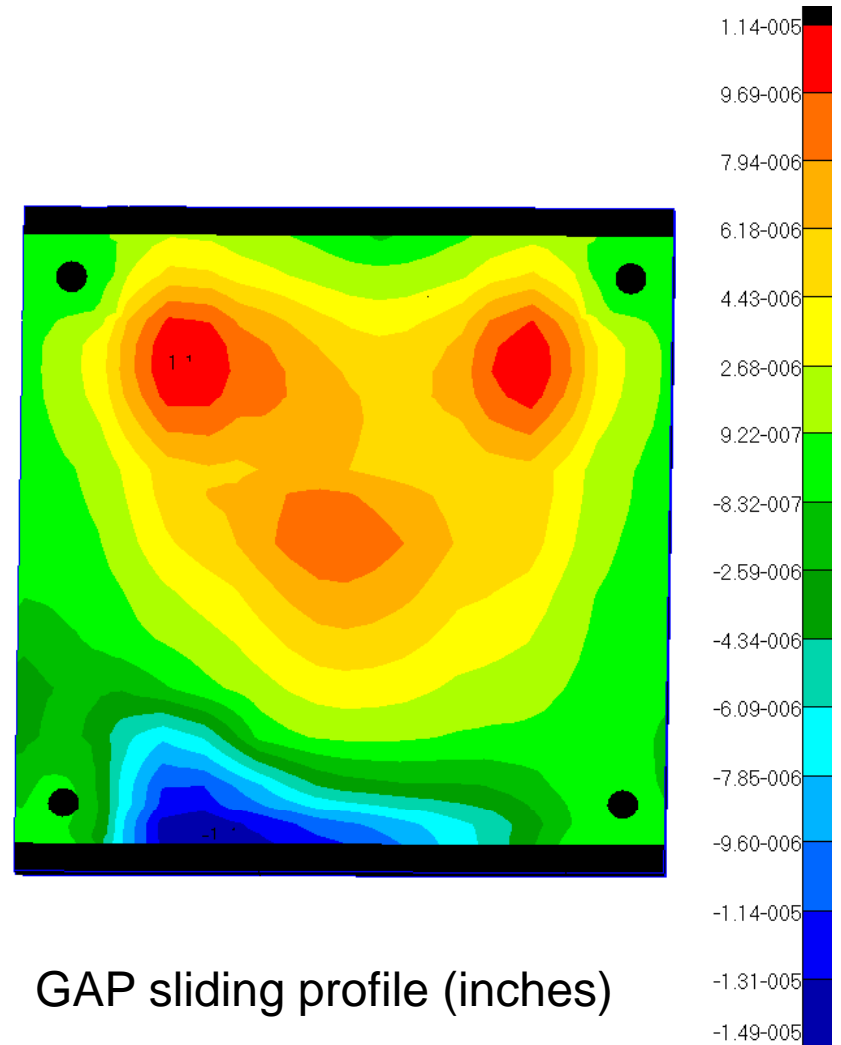

GAP sliding profile (inches)

default_Fringe :
Max 1.14-005 @Nd 128121
Min -1.49-005 @Nd 128752

Complete Summary explanation for all Runs

From the examinations of the six different FEA simulations presented by the above slides, the following evaluation can be stated:

- Basic FEA geometry simulations (nodal points, elements), for all runs, are the identical.
- The differences are in the applications of the model support/boundary conditions (SPCs) and their locations for each specific run. This was implemented in order to fully investigate the worst possible magnitude and locations of stresses and strains in the critical areas (especially the welded locations between the VV and the support structure).
- Runs #1, #2 and #3 are fully linear (the sliding effects were not considered). GAPS were replaced with RBE2 rigid elements. Runs #4, #5, #6 are non linear (NASTRAN Solution 106) where GAPS were fully utilized to evaluate the contributions due to the VV-Chair sliding effects. For these runs, GAP element contours are included to evaluate the correctness of the load transmission at the sliding surface (see the appropriate slides).
- Runs #1 and #2 were included here only for model verification and to demonstrate the effects of some extreme boundary support conditions which are used to improve the total model simulations.

In general, the following can be concluded and recommended for minimizing stresses and strains: For Run #1 under the most severe boundary conditions, the maximum stresses in the weld locations are equal to 15,300. psi. For Run #2 (less severe boundary condition) maximum weld stress decrease to 10,200. psi. From these two runs, the maximum possible stresses are established for total VV dead weight effects. Inclusion of the additional static loads may change the locations as well as the stress/strain values.

Complete Summary explanation for all Runs (cont.)

Welds Maximum

Chair Body Maximum

Run #	VM Stress	Strain	VM Stress	Strain
#1	15,300. psi	.0004	56,700.*	.0002
#2	10,200.	.0005	12,500.	.0005
#3	10,500.	.0003	15,500.	.000444
#4	11,100.	.00032	15,200.	.000438
#5	15,700.	.00045	21,100.	.00061
#6	16,200.	.00047	21,500.	.00062

* This stress is high because of the conservative boundary conditions used and should be disregarded.
(see RUN #1 results slides)

Final conclusion - Recommendations

Stainless steel with a yield stress of 42,000 psi was used for these analyses. Comparing to the above table, all the stress and strains are well within allowable limits (with the exception of Run #1 as noted above) and provides an adequate static margin for welds and the support structure alike.

Strong recommendation is to weld corner locations carefully in order to minimize the stress concentrations there (see Slide 30). It is advised that regular inspections of these locations should be performed.

Appendix A

All the data is saved in the following locations and it includes: the write up, analyses data base which includes all the analyses groups, input files for all completed runs (.bdf files), and the output results (.xdb files).

Folder name is “Vessel-Support-Chair-Data”

P:\public\Snap-srv\progoff

G:\Nastran P.R. - (external drive on ASALEHZ-64PC)